

752

Trykk nr. 752

Tjenesteskifter utgitt av Norges Statsbaner.

Hovedstyret.

M



ILLUSTRERT FORTEGNELSE

OVER

GODSVOGNER

NORMALSPOR

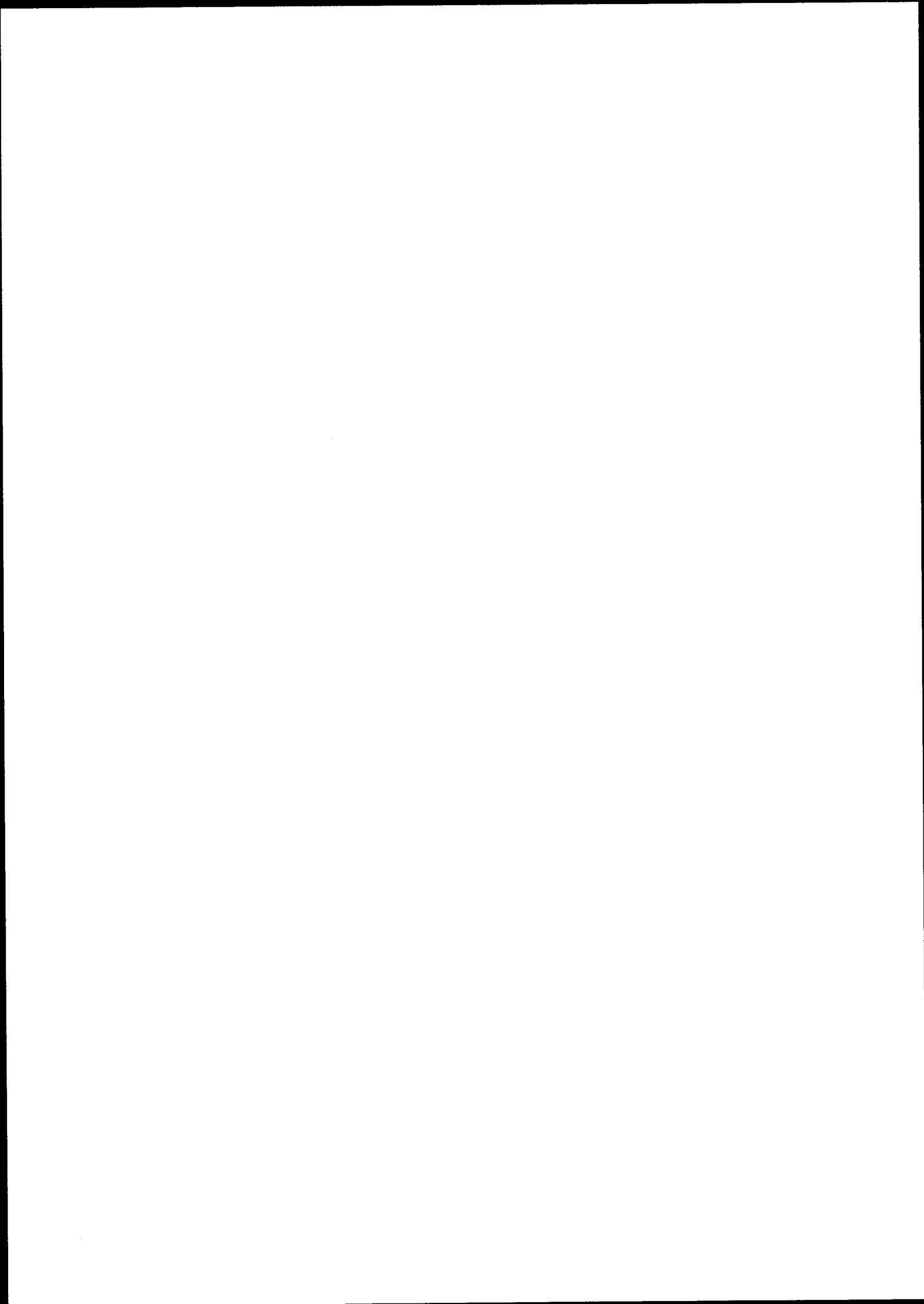

Trykk 752 pr. 1.1 1968

Vedlagt 139 blad til illustrert fortegnelse over godsvogner, Trykk nr. 752. Oversikt over gjeldende blad viser hvilke blad som er revidert pr. 1.1.68.

Følgende typer er gått ut i tiden 1.1. - 31.12.67:

G2	type 6	To	type 2	38211
Hf4	" 1	"	" 3	38212, 38226
Lk1	" 1	"	" 4	38213, 38244
Msf3	" 1	"	" 5	38207, 38248
S1	" 1	U5	" 2	
Sf1	" 2			

Nye typer:

Ibcdghps		To	type 3	38212, 38226
Ls		"	" 4	38204, 38248
Lt4	type 2	"	" 5	38203, 38243
Lto2	" 1	"	" 6	38200, 38247
√4	" 5	"	" 7	38201, 38237
To	" 1	38202, 38216	Tso4	" 1
"	" 2	38211	Ucs	" 2

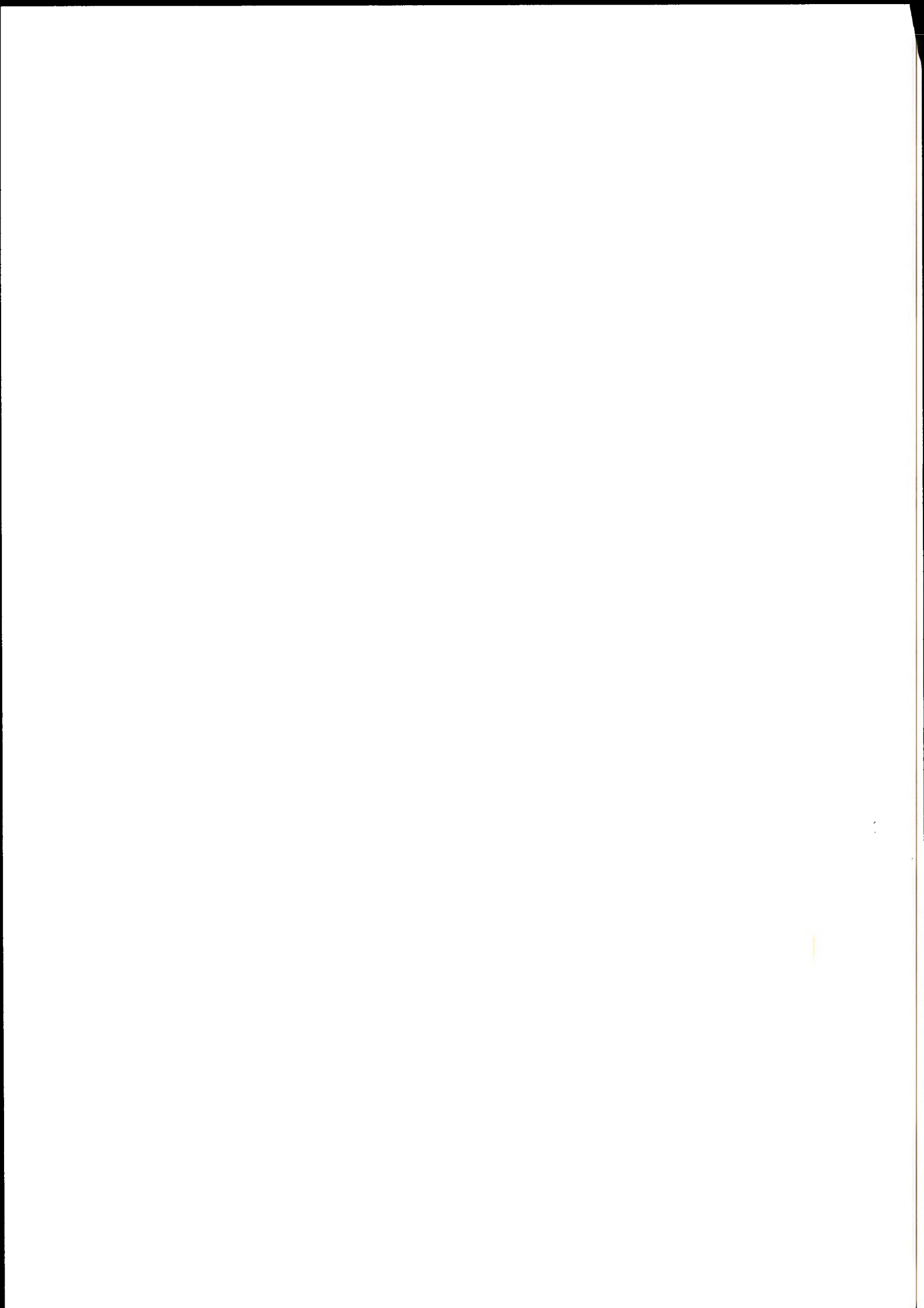

LITRABETEGNELSER

Bokstavmerket	Elo	= Kassevogn. Internasjonal litra
"	G	= Lukket godsvogn
"	Gbkls	= " " Internasjonal litra
"	Gbs	= " " " "
"	Gh	= Hestetransportvogn
"	Gl	= Lukket godsvogn
"	Gp	= " " (for reiseogs i hurtig- gående persontog)
"	Gr	= Lukket godsvogn
"	Grs	= " " Internasjonal litra
"	Gs	= " " " "
"	Gtk	= " " med skyvbare vegger og tak
"	Gtl	= " " " " " " "
"	H	= Kjölevogn
"	Ha	= Kjölevogn med aggregat for maskinell kjöling
"	Hbs	= Lukket godsvogn. Internasjonal litra
"	His	= " " " "
"	Hv	= Kjöle- og varmevogn
"	Ibcdghps	= Kjölevogn med aggregat for maskinell kjöling. Internasjonal litra
"	Ickmors	= Kjölevogn. Internasjonal litra
"	Icmors	= " " " "
"	Imors	= " " " "
"	K	= Tömmervogn
"	L	= Kassevogn
"	Laas	= Spesialvogn for transport av semitrailere. Internasjonal litra
"	Lg	= Gjödselvogn
"	Lk	= Kalkvogn
"	Ls	= Spesialvogn for transport av semitrailere. Internasjonal litra.
"	Lt	= Trekullvogn, flisvogn o.l.
"	M	= Grusvogn
"	Ms	= Spesial grusvogn
"	MK	= Grus- og tömmervogn
"	N	= Stakevogn
"	NP	= Stake- og malmvogn
"	Om	= Plattformvogn med nedleggbare jernlemmer. Internasjonal litra
"	Os	= Plattformvogn med nedleggbare jernlemmer. Internasjonal litra
"	Q	= Tankvogn

Bokstavmerket	S	=	Melkvogn
"	T	=	Plattformvogn
"	Tl	=	Plattformvogn med nedleggbare jernlemmer
"	Tr	=	Transformatorvogn
"	Trq	=	"
"	Ts	=	Spesial plattformvogn
"	U	=	Massegodsvogn
"	Uac	=	" Internasjonal litra
"	Ucs	=	" " "
"	Udg	=	" " "
"	Udgk	=	" " "
"	Zl	=	Liktransportvogn
"	Ö	=	Bunntømmingsvogn

o etter bokstavmerket betegner at vognen er boggivogn

f " " " " " har bremsarhus

Indeks	1:	Vogner med inntil	9	tonns akseltrykk og liten vognkasse
"	2:	" " "	9	" " og større vognkasse
"	3:	" " "	12	" "
"	4:	" " "	14-15	" "
"	5:	" " "	20	" "

OVERSIKT OVER GJELDENE BLAD I TRYKK NR. 752

pr. 1.1.68. Neste revisjon 1.1.69

Side 1

SIDE (Hver enkelt side an- gis ved litrabe- tegnelsen og første og siste vognnummer)	DATO for siste revisjon	SIDE (Hver enkelt side an- gis ved litrabe- tegnelsen og første og siste vognnummer)	DATO for siste revisjon
G-1, 33210, 33652	1.1.61	G4-1, 40655, 40723	1.1.67
G-1, 33699, 34129	1.1.61	G4-1, 40725, 40795	1.1.67
G-2, 33000, 33048	1.1.61	G4-1, 40796, 40862	1.1.66
G-2, 33049, 34214	1.1.61	G4-1, 40863, 40932	1.1.59
G-3, 34223	1.1.62	G4-1, 40933, 41003	1.1.61
G1-1, 5066, 15165	1.1.60	G4-1, 41004, 41073	
G1-2, 1142, 8084	1.1.59	G4-1, 41074, 41142	1.1.68
G1-3, 8409, 8414	1.1.64	G4-1, 41143, 41211	1.7.56
G2-1, 1166, 9238	1.1.66	G4-1, 41212, 41279	1.1.68
G2-1, 10307, 20614	1.1.68	G4-1, 41280, 41348	1.1.59
G2-4, 14078, 17059	1.1.68	G4-1, 41349, 41418	1.1.59
G3-1, 2949, 3115	1.1.68	G4-1, 41419, 41839	1.1.62
G3-1, 3130, 3591	1.1.68	G4-1, 41840, 41887	1.1.66
G3-1, 3599, 8190	1.1.68	Gbkls, 158 5023,	
G3-1, 8195, 10344	1.1.68	158 5044	1.1.68
G3-1, 10353, 15264	1.1.68	G4-2, 42005, 42034	1.1.68
G3-1, 15269, 20165	1.1.68	G4-2, 42035, 42104	1.1.68
G3-1, 20173, 23380	1.1.68	G4-2, 42105, 42174	1.1.68
G3-2, 31028, 32041	1.1.68	G4-2, 42175, 42244	1.1.68
G3-3, 31001, 31012	1.1.68	G4-2, 42245, 42314	1.1.68
G3-4, 3161, 10198	1.1.68	G4-2, 42315, 42352	1.1.68
G3-4, 10201, 23074	1.1.68	Gbkls 158 6004,	
G3-5, 6286	1.1.65	158 6340	1.1.68
G4-1, 40000, 40028	1.1.65	G5-1, 43000, 43029	1.1.68
G4-1, 40029, 40095	1.1.68	G5-1, 43030, 43034	1.1.68
G4-1, 40096, 40166	1.1.67	Gs, 120 0022,	
G4-1, 40167, 40236	1.1.67	120 0033	1.1.68
G4-1, 40237, 40307		G5-2, 43035, 43047	1.1.68
G4-1, 40308, 40376	1.1.68	G5-2, 43049, 43115	1.1.68
G4-1, 40377, 40447	1.1.68	G5-2, 43120, 43186	1.1.68
G4-1, 40448, 40515	1.1.68	G5-2, 43193, 43258	1.1.68
G4-1, 40516, 40584	1.1.62	G5-2, 43259, 43331	1.1.68
G4-1, 40585, 40654	1.1.67	G5-2, 43332, 43401	1.1.68
		G5-2, 43403, 43409	1.1.68

Der hvor datorubrikken står åpen, gjelder datoen for den opprinnelige utgave: 1.7.54.

OVERSIKT OVER GJELDENE BLAD I TRYKK NR. 752

pr. 1.1.68. Neste revisjon 1.1.69

Side 2

SIDE (Hver enkelt side an- gis ved litrabe- tegnelsen og første og siste vognnummer)	DATO for siste revisjon	SIDE (Hver enkelt side an- gis ved litrabe- tegnelsen og første og siste vognnummer)	DATO for siste revisjon
Grs, 131 0001, 131 0034	1.1.68	Gfo2-1, 6201, 14100	1.1.68
Gs, 120 1026, 120 1117	1.1.68	Gfo2-2, 3340, 14136	1.1.67
Gs, 120 1118, 120 1320	1.1.68	Gfo2-3, 3408, 15406	1.1.68
G5-3, 43410, 43437	1.1.68	Gh4-1, 1250	1.1.68
G5-3, 43438, 43500	1.1.68	G14-1, 48001, 48027	1.1.68
G5-3, 43513, 43577	1.1.68	G14-1, 48028, 48049	1.1.68
G5-3, 43578, 43609	1.1.68	Glm, 103 0000, 103 0029	1.1.68
Gs, 120 2003, 120 2111	1.1.68	Gp4-1, 33101, 33126	1.1.68
Gs, 120 2112, 120 2163	1.1.68	Gp4-1, 33130, 33160	1.1.68
G5-4, 44000, 44029	1.1.68	Gklms 139 5000, 139 5056	1.1.68
G5-4, 44030, 44099	1.1.65	Gr5-1, 46000, 46026	1.1.68
G5-4, 44100, 44169	1.1.66	Gr5-1, 46032, 46097	1.1.68
G5-4, 44170, 44239	1.1.66	Gr5-1, 46098, 46167	1.1.68
G5-4, 44240, 44309	1.1.66	Gr5-1, 46168, 46237	1.1.68
G5-4, 44310, 44379	1.1.68	Gr5-1, 46238, 46299	1.1.66
G5-4, 44427, 44470	1.1.67	Gbs, 150 0003, 150 0213	1.1.68
His, 210 2334, 210 2491	1.1.68	Gbs, 150 0215, 150 0226	1.1.68
His, 210 2492, 210 2561	1.1.68	Hbs, 210 9022, 210 9023	1.1.68
His, 210 2562, 210 2631	1.1.68	Gtk5-1, 49500, 49519	1.1.63
His, 210 2632, 210 2701	1.1.68	Gt15-1, 49000, 49009	1.1.63
His, 210 2802, 210 2871	1.1.68	H-1, 70500	1.1.64
His, 210 2902, 210 2950	1.1.68	H3-1, 13101, 13134	1.1.68
Gf2-1, 6266, 8116	1.1.64	H3-1, 13139, 13237	1.1.68
Gf2-2, 2056	1.1.66	H3-1, 13238, 13312	1.1.68
Gf3-2, 13013, 13020	1.1.68	H3-1, 13313, 13379	1.1.68
		H3-1, 13381, 13404	1.1.68
		H4-1, 70002, 70020	1.1.68
		Icmors, 806 6016, 806 6024	1.1.68

Der hvor datorubrikken står åpen, gjelder datoen for den opprinnelige utgave: 1.7.54.

OVERSIKT OVER GJELDENE BLAD I TRYKK NR. 752

pr. 1.1.68. Neste revisjon 1.1.69

Side 3

SIDE (Hver enkelt side an- gis ved litrabe- tegnelsen og første og siste vognnummer)	DATO for siste revisjon	SIDE (Hver enkelt side an- gis ved litrabe- tegnelsen og første og siste vognnummer)	DATO for siste revisjon
Ickmors, 806 6002, 806 6015	1.1.68	L4-3, 50047, 50136	1.1.68
H4-2, 70026, 70066	1.1.68	L4-3, 50137, 50208	1.1.68
H4-2, 70067, 70074	1.1.68	L4-3, 50211, 50279	1.1.68
Imors, 806 6025, 806 6073	1.1.68	L4-3, 50285, 50371	1.1.68
Ha5-1, 70100, 70110	1.1.68	L4-3, 50372, 50468	1.1.68
Hf3-1, 13327, 13400	1.1.68	Elo, 511 0005, 511 0340	1.1.68
Hf4-2, 70031, 70069	1.1.68	Lo3-1, 23701, 23724	1.1.64
Hv3-1, 13281	1.1.68	Laas, 430 5000	1.1.68
Hv4-1, 70000	1.1.68	Lf3-1, 13001, 13085	1.1.68
Hvf4-2, 70052	1.1.68	Lf4-1, 11399, 32628	1.1.65
Ibcdghps, 818 1011, 818 1016	1.1.68	Lg1-1, 2303, 11450	1.1.64
K1-1, 2153, 2160	1.1.61	Lk3-1, 6715, 15909	1.1.68
K1-2, 1384, 2260	1.1.68	Lk3-1, 15920, 16515	1.1.68
K1-3, 1313	1.1.64	Ls, 410 0001, 410 0007	1.1.68
K2-1, 15502, 23055	1.1.67	Lt2-3, 7616, 7735	1.1.68
K2-1, 23057, 23441	1.1.66	Lt4-1, 7100, 7129	1.1.60
L1-1, 1420, 1569	1.1.62	Lt4-1, 7130, 7159	1.1.68
L1-2, 8305, 15708	1.1.65	Lt4-2, 50015, 50316	1.1.68
L2-1, 2919	1.1.63	Lto2-1, 3402	1.1.68
L3-1, 13033, 13038	1.1.64	M1-1, 2267, 2390	1.1.68
L3-2, 3174, 3729	1.1.68	M1-1, 2392, 11503	1.1.68
L3-2, 3730, 12847	1.1.68	M1-1, 11505, 20829	1.1.68
L3-2, 12854, 16577	1.1.68	M1-1, 20830, 20849	1.1.67
L3-2, 16578, 20273	1.1.68	M1-2, 8244, 8274	1.1.68
L3-5, 15777, 15789	1.1.68	M1-2, 8275, 20527	1.1.68
L3-7, 10042	1.1.66	M1-3, 23389	1.1.64
L4-1, 10552, 32140	1.1.68	M2-1, 5490, 23021	1.1.68
L4-1, 32146, 32645	1.1.68	M2-1, 23022, 23493	1.1.68
L4-2, 11195, 32260	1.1.68	Mf1-1, 2367, 3816	1.1.68
L4-2, 32262, 32648	1.1.68	Mf1-2, 8283, 20530	1.1.67
L4-3, 50001, 50044	1.1.68	Mf2-1, 5491, 23495	1.1.66

Der hvor datorubrikken står åpen, gjelder datoen for den opprinnelige utgave: 1.7.54.

OVERSIKT OVER GJELDENE BLAD I TRYKK NR. 752

pr. 1.1.68. Neste revisjon 1.1.69

Side 4

SIDE (Hver enkelt side an- gis ved litrabe- tegnelsen og første og siste vognnummer)	DATO for siste revisjon	SIDE (Hver enkelt side an- gis ved litrabe- tegnelsen og første og siste vognnummer)	DATO for siste revisjon
Ms3-1, 8229, 8237	1.1.68	Qo2-1, 73030, 73031	1.1.68
Ms3-2, 2127, 15886	1.1.68	S3-1, 4517, 4530	1.1.68
Ms3-2, 15887, 15899	1.1.68	S3-1, 4533, 20771	1.1.68
Msf3-2, 6995, 15900	1.1.65	S3-2, 2903, 2970	1.1.68
MK1-1, 6150	1.1.68	Sf3-1, 4527	1.1.61
MK3-1, 20231, 20250	1.1.63	Sf3-2, 2902, 16588	1.1.68
N1-1, 1818, 8584	1.1.66	T-1, 38601	1.1.63
N1-1, 8597, 20846	1.1.67	T3-1, 2985, 4824	1.1.68
N1-2, 1688, 11688	1.1.68	T3-1, 4825, 5375	1.1.68
N2-1, 2402, 10869	1.1.68	T3-1, 5380, 6583	1.1.68
N2-1, 10872, 11895	1.1.68	T3-1, 6584, 6797	1.1.68
N2-2, 3635, 3841	1.1.68	T3-1, 6824, 14503	1.1.68
N2-2, 3843, 5603	1.1.68	T3-1, 14504, 17005	1.1.68
N2-2, 5606, 6687	1.1.68	T3-1, 17006, 17162	1.1.68
N2-2, 6689, 9600	1.1.68	T3-1, 17551, 17563	1.1.68
N2-2, 9601, 16424	1.1.68	T4-1, 60001, 60035	1.1.68
N2-2, 16432, 20149	1.1.68	T4-1, 60037, 60113	1.1.68
N2-2, 20150, 23006	1.1.68	T4-1, 60114, 60201	1.1.68
N2-3, 2441, 7525	1.1.68	T4-1, 60203, 60929	1.1.68
N2-3, 8504, 16445	1.1.68	T4-1, 60933, 61267	1.1.68
N2-4, 10886, 12541	1.1.67	Kbmp, 312 7000, 312 7301	1.1.68
N3-1, 13005, 13096		Kbmp, 312 7302, 312 7308	1.1.68
No2-1, 10936, 10937	1.1.66	To-1, 38202, 38216	1.1.68
NP2-1, 5310, 16359	1.1.68	To-2, 38211	1.1.68
NP3-1, 13054, 13094	1.1.68	To-3, 38212, 38226	1.1.68
NPo3-1, 13042, 13081	1.1.61	To-4, 38204, 38248	1.1.68
Q3-2, 4957, 4988	1.1.68	To-5, 38203, 38243	1.1.68
Q3-3, 11301, 11302	1.7.57	To-6, 38200, 38247	1.1.68
Q4-1, 60080, 60163		To-7, 38201, 38237	1.1.68
Q4-2, 11303, 73012	1.1.67	To1-1, 14901, 15997	1.1.66
Q4-3, 73013, 73027	1.1.68	To3-1, 6841, 6845	
Q4-4, 50157	1.1.66		
Q4-5, 73029	1.1.68		

Der hvor datorubrikken står åpen, gjelder datoen for den opprinnelige utgave: 1.7.54.

OVERSIKT OVER GJELDENE BLAD I TRYKK NR. 752

pr. 1.1.68. Neste revisjon 1.1.69

Side 5

SI DE (Hver enkelt side an- gis ved litrabe- tegnelsen og første og siste vognnummer)	DATO for siste revisjon	SI DE (Hver enkelt side an- gis ved litrabe- tegnelsen og første og siste vognnummer)	DATO for siste revisjon
To4-1, 60416, 60446	1.1.66	T14-1, 61366, 61370	1.1.63
To4-1, 60447, 60485		Om, 361 0010,	
To4-2, 65000, 65019	1.1.60	361 0537	1.1.68
Tr-1, 38395, 38422	1.1.63	Om, 361 0538,	
Tr-1, 38423, 38492	1.1.63	361 0952	1.1.68
Tr-1, 38493, 38562	1.1.63	T15-1, 62003, 62022	1.1.68
Tr-1, 38563, 38599	1.1.66	T15-1, 62036, 62097	1.1.68
T13-1, 2986, 4246	1.1.68	T15-1, 62098, 62167	1.1.68
T13-1, 4247, 5398	1.1.68	T15-1, 62168, 62237	1.1.67
T13-1, 5474, 6789	1.1.68	T15-1, 62238, 62307	1.1.66
T13-1, 6792, 7000	1.1.68	T15-1, 62308, 62377	1.1.66
T13-1, 10441, 10533	1.1.68	T15-1, 62378, 62447	1.1.66
T13-1, 10534, 10700	1.1.68	T15-1, 62448, 62469	1.1.67
T13-1, 10914, 10993	1.1.68	Os, 370 0000,	
T13-1, 10995, 15554	1.1.68	370 0471	1.1.68
T13-1, 15555, 16517	1.1.68	Os, 370 0472,	
T13-1, 16518, 17163	1.1.68	370 0543	1.1.68
T14-1, 60206, 60234	1.1.68	Os, 370 0544,	
T14-1, 60235, 60303	1.1.68	370 0614	1.1.68
T14-1, 60304, 60373	1.1.68	Os, 370 0615,	
T14-1, 60374, 60524	1.1.68	370 0684	1.1.68
T14-1, 60526, 60594	1.1.68	Os, 370 0685,	
T14-1, 60595, 60663	1.1.68	370 0754	1.1.68
T14-1, 60664, 60734	1.1.68	Os, 370 0755,	
T14-1, 69736, 60805	1.1.68	370 0779	1.1.68
T14-1, 60806, 60877	1.1.68	T103-1, 4926, 16591	1.1.61
T14-1, 60881, 60944	1.1.68	T104-1, 60486, 60495	1.1.60
T14-1, 60948, 61016	1.1.68	Tr5-1, 16510, 16511	1.1.59
T14-1, 61018, 61085	1.1.68	Tro-1, 39000	1.1.63
T14-1, 61087, 61156	1.1.68	Tro4-1, 16506	1.1.65
T14-1, 61157, 61226	1.1.68	Tro4-2, 16505	1.1.59
T14-1, 61227, 61295	1.1.68	Tro5-1, 16507	1.1.59
T14-1, 61296, 61365	1.1.68	Trq0-1, 16000, 16001	1.1.67
		Trq05-1, 16100	1.1.65
		Tso2-1, 4380, 15991	1.1.63

Der hvor datorubrikken står åpen, gjelder datoen for den opprinnelige utgave: 1.7.54.

OVERSIKT OVER GJELDENE BLAD I TRYKK NR. 752

pr. 1.1.68. Neste revisjon 1.1.69

Side 6

SIDE (Hver enkelt side an- gis ved litrabe- tegnelsen og første og siste vognnummer)	DATO for siste revisjon	SIDE (Hver enkelt side an- gis ved litrabe- tegnelsen og første og siste vognnummer)	DATO for siste revisjon
Tso2-2, 17164	1.1.63		
Tso3-1, 5405, 15994	1.1.65		
Tso4-1, 20850	1.1.68		
Tsfo3-1, 5406, 15995	1.1.65		
U4-1, 75000, 75003	1.1.61		
U4-2, 75100, 75129	1.1.68		
Udgk, 907 9004, 907 9005	1.1.68		
U5-1, 75004, 75007	1.1.63		
Uac, 920 5000	1.1.67		
Ucs-1, 910 5000, 910 5004	1.1.68		
Ucs-2, 910 5005, 910 5014	1.1.68		
Udg, 902 9000, 902 9009	1.1.68		
Z1-3, 4962, 9960	1.7.57		
Ö2-1, 16701, 16729	1.1.68		
Ö2-1, 16730, 16796	1.1.68		
Ö2-1, 16797, 16865	1.1.68		
Ö2-1, 16866, 16934	1.1.66		
Ö2-1, 16935, 20808	1.1.68		
Ö3-1, 74021, 74024	1.1.59		
Ö4-1, 17565, 17605	1.1.68		
Ö4-1, 17606, 17614	1.1.68		
Ö4-2, 16952, 16979	1.1.62		
Ö4-2, 16980, 17418	1.1.68		
Ö4-2, 17419, 17488	1.1.68		
Ö4-2, 17489, 17500	1.1.68		
Ö4-3, 17593, 17602	1.1.68		
Öo4-1, 74000, 74001	1.1.61		
Öo4-2, 74002, 74003	1.1.63		
Öo4-3, 12003, 12009	1.1.68		
Öf4-1, 17598, 17601	1.1.67		

Der hvor datorubrikken står åpen, gjelder datoen for den opprinnelige utgave: 1.7.54.

Vogn nr.	Fabr.	Byggear	Merknad	Vogn nr.	Fabr.	Byggear	Merknad
9247	Skb	09					
9249	"	"					
10307	"	06					
10324	Edf	10					
10327	"	"					
10328	"	"					
10338	"	"					
12162	Str	"					
12167	"	"					
14170	"	05					
14195	Skb	10					
20614	Edf	18					

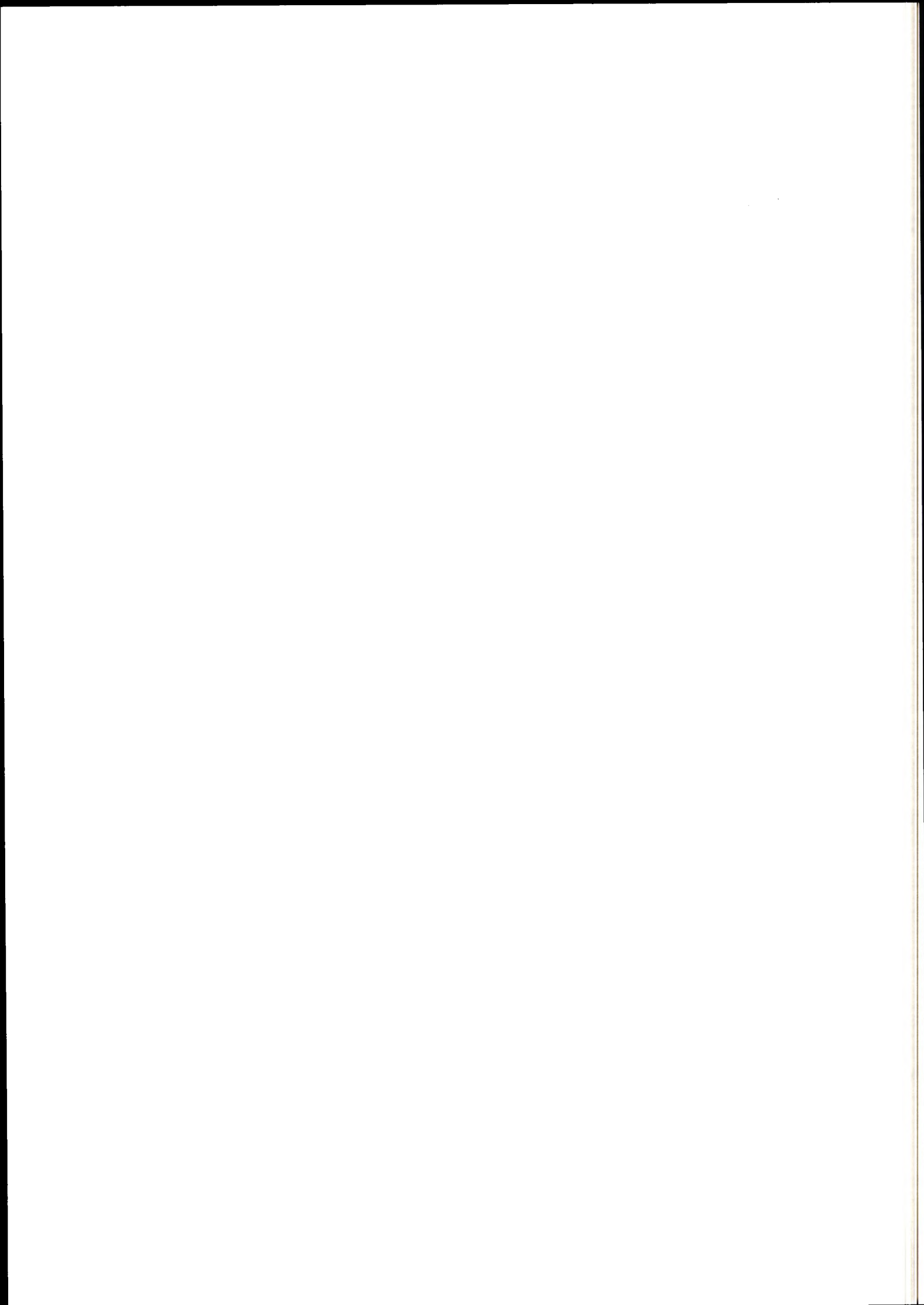

G2
TYPE 4

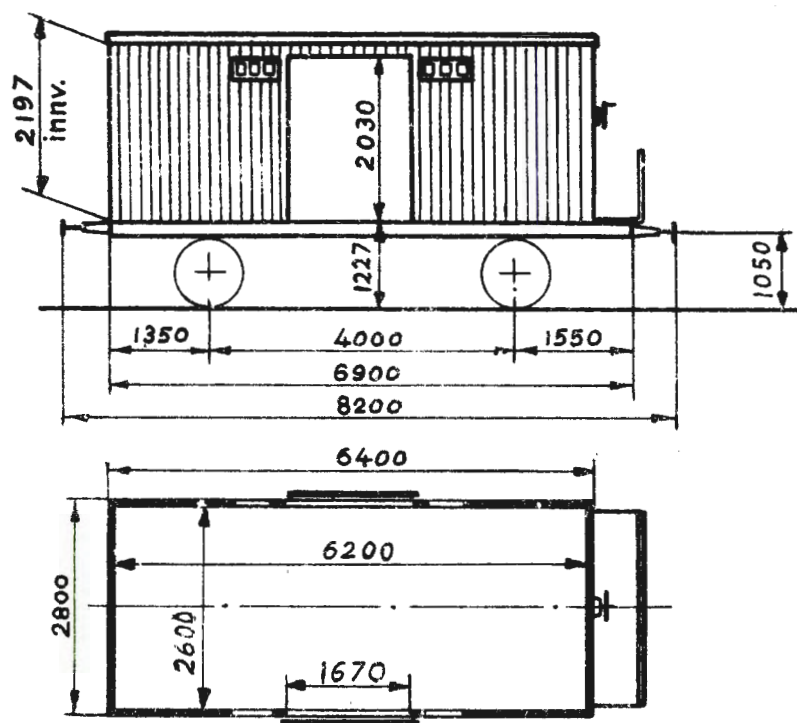

Omtrentlig vognvekt 8,0 t
 " bæreevne 9,5-10,5 t
 Gulvflate 16,1 m²
 Rominnhold 34,0 m³
 Hovedtegning 376 + skisse 233

LUKKET GODSVOGN

Vogn nr.	Fabr.	Byggeår	Merknad	Vogn nr.	Fabr.	Byggeår	Merknad
14075	Edf	10					
14078	"	"					
14085	"	"					
17059	Skb	"					

G3

TYPE 1

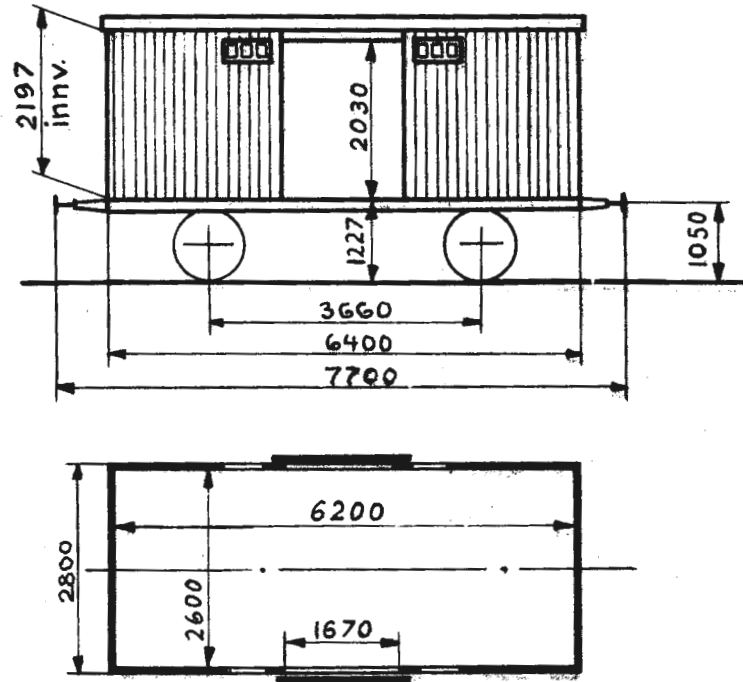

Bæreevne

A	B	C
16,0 t	16,0 t	

Omtrentlig vognvekt

Gulvflate

Rominnhold

Hovedtegning

7,5-9,5 t

16,1 m²

34,0 m³

376

LUKKET GODSVOGN

Vogn nr.	Fabr.	Byggeår	Merknad	Vogn nr.	Fabr.	Byggeår	Merknad
2945	Edf	08		3075	Skb	08	
2946	"	"		3076	"	"	
2947	"	"		3081	"	"	
2949	"	"		3083	"	"	
3055	Skb	"		3087	"	"	
3057	"	"		3091	"	"	
3059	"	"		3094	"	"	
3062	"	"		3097	"	"	
3064	"	"		3099	"	"	
3065	"	"		3100	"	"	
3066	"	"		3107	"	"	
3067	"	"		3108	"	"	
3068	"	"		3109	"	"	
3071	"	"		3110	"	"	
3073	"	"		3115	"	"	

Vogn nr.	Fabr.	Byggeår	Merknad	Vogn nr.	Fabr.	Byggeår	Merknad
3118	Skb	08		3334	Edf	10	
3119	"	"		3349	"	22	
3125	Edf	"		3352	"	"	
3127	"	"		3354	"	"	
3128	"	"		3357	"	"	
3130	"	"		3358	"	"	
3134	"	09		3360	"	"	
3135	"	"		3361	"	"	
3136	"	"		3364	"	"	
3138	"	"		3365	"	23	
3142	"	"		3367	"	"	
3143	"	"		3368	"	"	
3144	"	"		3371	Skb	24	
3146	"	"		3372	"	"	
3148	"	"		3373	"	"	
3150	"	"		3376	"	"	
3151	"	"		3377	"	"	
3152	"	"		3379	"	"	
3153	"	"		3381	"	"	
3156	"	"		3384	"	"	
3158	"	"		3385	"	25	
3159	"	"		3386	"	"	
3172	Skb	26		3387	"	"	
3173	"	"		3388	"	"	
3175	"	"		3389	"	"	
3176	"	"		3390	"	"	
3178	"	"		3391	"	"	
3316	Edf	10		3394	"	"	
3317	"	"		3581	"	26	
3319	"	"		3583	"	"	
3320	"	"		3587	"	"	
3323	"	"		3588	"	"	
3327	"	"		3589	"	"	
3328	"	"		3590	"	"	
3332	"	"		3591	"	"	

Vogn nr.	Fabr.	Byggeår	Merknad	Vogn nr.	Fabr.	Byggeår	Merknad
3592	Skb	26		5663	Edf	14	
3599	"	"		5664	"	"	
3600	"	"		6087	"	09	
5437	AaB	"		6091	"	"	
5438	"	"		6092	"	"	
5441	"	"		6094	"	"	
5443	"	"		6097	"	"	
5445	"	"		6099	"	"	
5448	Skb	27		6100	"	"	
5450	"	"		6102	"	"	
5452	"	"		6106	"	"	
5454	"	"		6110	"	"	
5456	"	"		6114	"	"	
5461	"	"		8149	Skb	08	
5462	"	"		8151	"	"	
5463	"	"		8153	"	"	
5464	"	"		8157	"	"	
5466	"	"		8160	"	"	
5638	Edf	14		8162	"	"	
5641	"	"		8166	"	"	
5642	"	"		8167	"	"	
5644	"	"		8168	"	"	
5646	"	"		8169	"	"	
5647	"	"		8170	"	"	
5648	"	"		8171	"	"	
5649	"	"		8173	"	"	
5652	"	"		8174	Edf	09	
5653	"	"		8175	"	"	
5654	"	"		8179	"	"	
5656	"	"		8180	"	"	
5657	"	"		8182	"	"	
5658	"	"		8185	"	"	
5659	"	"		8187	"	"	
5660	"	"		8190	"	"	
5661	"	"		8193	"	"	

Vogn nr.	Fabr.	Byggeår	Merknad	Vogn nr.	Fabr.	Byggeår	Merknad
8195	Edf	12		8384	Str	23	
8196	Str	16		8386	"	"	
8198	"	"		8389	"	"	
8199	"	"		8390	"	"	
8200	"	"		8391	"	"	
8291	Skb	26		8394	"	"	
8293	"	"		8395	"	"	
8295	"	"		8396	"	"	
8296	"	"		8397	"	"	
8299	"	"		8398	"	"	
8300	"	"		8400	"	"	
8319	Str	16		8422	Skb	26	
8324	"	"		8423	"	"	
8325	"	"		8425	"	"	
8329	"	"		8426	"	"	
8332	"	"		8427	"	"	
8333	"	"		8429	"	"	
8334	"	"		10208	Str	23	
8335	"	"		10209	"	"	
8336	"	"		10211	"	"	
8337	"	"		10216	"	"	
8339	"	"		10219	"	"	
8344	"	"		10220	"	"	
8345	"	"		10223	"	"	
8346	"	"		10225	"	"	
8347	"	"		10227	"	"	
8348	"	"		10229	"	"	
8349	"	"		10230	"	"	
8353	Edf	"		10231	"	"	
8359	"	"		10340	Edf	26	
8364	"	"		10341	"	"	
8365	"	"		10343	"	"	
8367	"	"		10344	"	"	
8377	Str	23		10345	"	"	
8379	"	"		10347	"	"	

Vogn nr.	Fabr.	Byggeår	Merknad	Vogn nr.	Fabr.	Byggeår	Merknad
10350	Edf	26		14220	Skb	24	
10352	"	"		14222	"	25	
10353	"	"		14223	"	"	
10355	"	"		14225	"	"	
10357	"	"		14226	"	"	
12171	"	15		15193	Str	09	
12172	"	"		15195	"	"	3)
12174	"	"		15200	"	"	
12175	"	"		15202	"	"	
12176	"	"		15207	"	"	
12177	"	"		15208	"	"	
12178	"	"		15210	"	"	
14108	"	19		15211	Edf	"	
14109	"	"		15213	"	"	
14113	"	"		15214	"	"	
14116	"	"		15215	"	"	
14117	"	"		15216	"	"	
14118	"	"		15217	"	"	
14121	"	"		15220	"	"	
14122	"	"		15222	"	"	
14123	"	"		15224	"	"	
14126	"	"		15227	"	10	
14198	Skb	24		15230	"	"	
14200	"	"	1)	15231	"	"	
14201	"	"		15235	"	"	
14204	"	"		15238	"	"	
14205	"	"		15241	"	"	
14206	"	"		15244	"	"	
14207	"	"		15247	"	"	
14208	"	"		15258	"	20	
14211	"	"		15260	"	"	
14212	"	"		15262	"	"	
14214	"	"	2)	15263	"	"	
14215	"	"		15264	"	"	
14219	"	"		15265	"	"	

1) Stöpt gulv. Bæreevne 15,5 t. 2) Stöpt gulv. Bæreevne 15,0 t.
3) Ballast + v.v. = 12,2 t.

Vogn nr.	Fabr.	Byggear	Merknad	Vogn nr.	Fabr.	Byggear	Merknad
15269	Str	21		15364	Skb	25	
15271	"	"		15366	"	"	
15273	"	"		15367	"	"	
15275	"	"		15369	"	"	
15276	"	"		15370	"	"	
15277	"	"		15372	"	"	
15280	Edf	23		15374	"	"	
15282	"	"		15384	Edf	28	
15283	"	"		15386	"	"	
15284	"	"		15387	"	"	
15285	"	"		15390	"	"	
15286	"	"		15391	"	"	
15287	"	"		15392	"	"	
15289	"	"		15394	"	"	
15293	"	"		15396	"	"	
15294	"	"		15399	"	"	
15299	"	"		15402	"	"	
15305	Str	"		17171	Str	21	
15306	"	"		17173	"	"	
15307	"	"		17176	"	"	
15312	"	"		17180	"	"	
15313	"	"		17182	"	"	
15315	"	"		17183	"	"	
15316	"	"		17502	Edf	14	
15319	"	"		17504	"	"	
15320	"	"		17505	"	"	
15324	"	"		17508	"	"	
15325	"	"		20151	"	22	
15328	"	"		20152	"	"	
15355	Skb	24		20159	"	"	
15356	"	"		20161	"	"	
15358	"	"		20162	"	"	
15360	"	"		20164	"	"	
15362	"	25		20165	"	"	
15363	"	"		20169	"	"	

G3
TYPE 1

Vogn nr.	Fabr.	Byggeår	Merknad	Vogn nr.	Fabr.	Byggeår	Merknad
20171	Edf	22		23078	Str	19	
20173	"	"		23380	Skb	09	
20174	"	"					
20176	Str	"					
20177	"	"					
20179	"	"					
20181	"	"					
20182	"	"					
20183	"	"					
20185	"	"					
20189	"	"					
20190	"	"					
20191	"	"					
20193	"	"					
20195	"	"					
20196	"	"					
20198	"	"					
20199	"	"					
20200	"	"					
20775	Skb	26					
20777	"	"					
20778	"	"					
20779	"	"					
20781	"	"					
20782	"	"					
20783	"	"					
20785	"	"					
20786	"	"					
20787	"	"					
20789	"	"					
20793	"	"					
20794	"	"					
23075	Str	19					
23076	"	"					
23077	"	"					

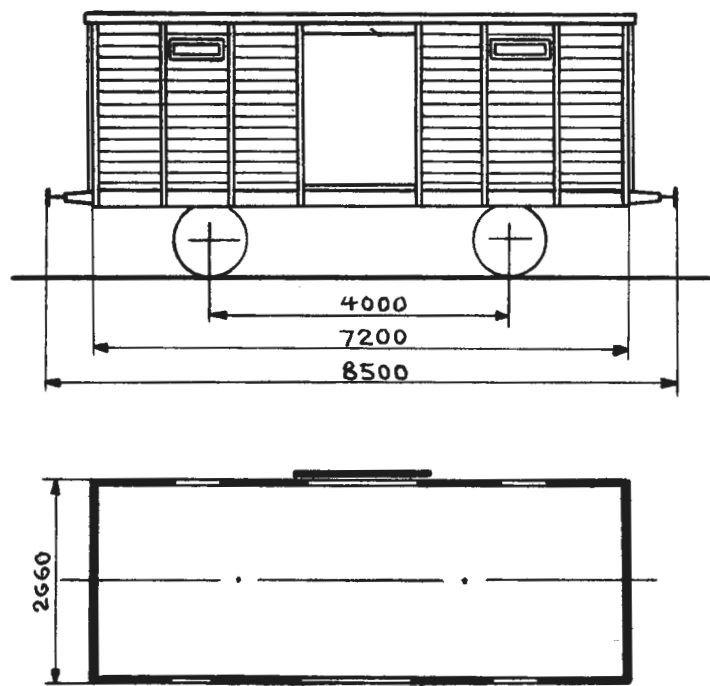

Omtrentlig vognvekt 7,5- 8,5 t
 " bæreevne 15,0-16,5 t
 Gulvflate 18,6 m²
 Rominnhold 37,9 m³
 Hovedtegning Vognene er innkjøpt
 fra Tyskland i 1915

LUKKET GODSVOGN

Vogn nr.	Fabr.	Byggeår	Merknad	Vogn nr.	Fabr.	Byggeår	Merknad
31028				31053			
31029				31054			
31032				31057			
31033				31058			
31034				32041			
31035				32044			
31036							
31037							
31038							
31040							
31041							
31044							
31048							
31049							
31051							

G3

TYPE 3

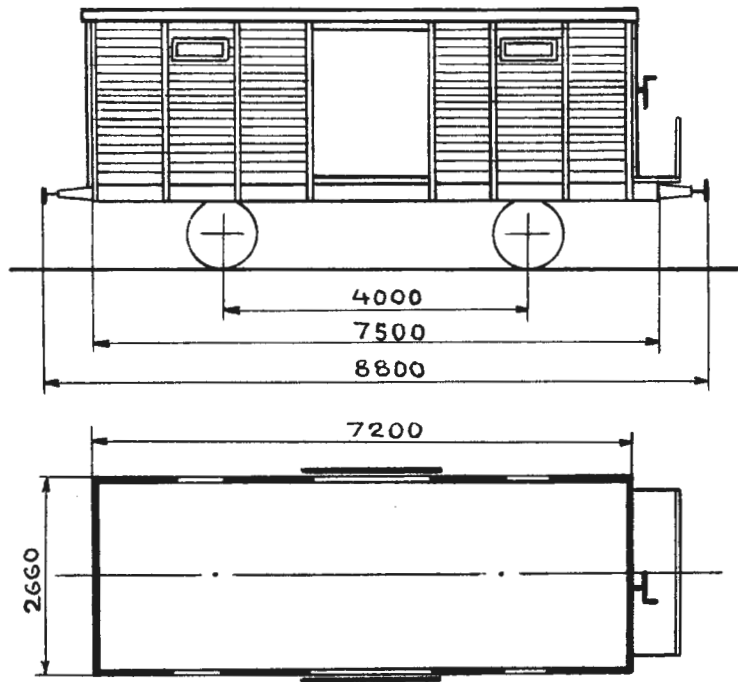

Omtrentlig vognvekt 9,0- 9,5 t
 " bæreevne 14,5-15,0 t
 Gulvflate 18,6 m²
 Rominnhold 37,9 m³
 Hovedtegning Vognene er innkjøpt
 fra Tyskland i 1915

LUKKET GODSVOGN

Vogn nr.	Fabr.	Byggeår	Merknad	Vogn nr.	Fabr.	Byggeår	Merknad
31001							
31002							
31003							
31004							
31005							
31006							
31007							
31008							
31009							
31010							
31011							
31012							

G3

TYPE 4

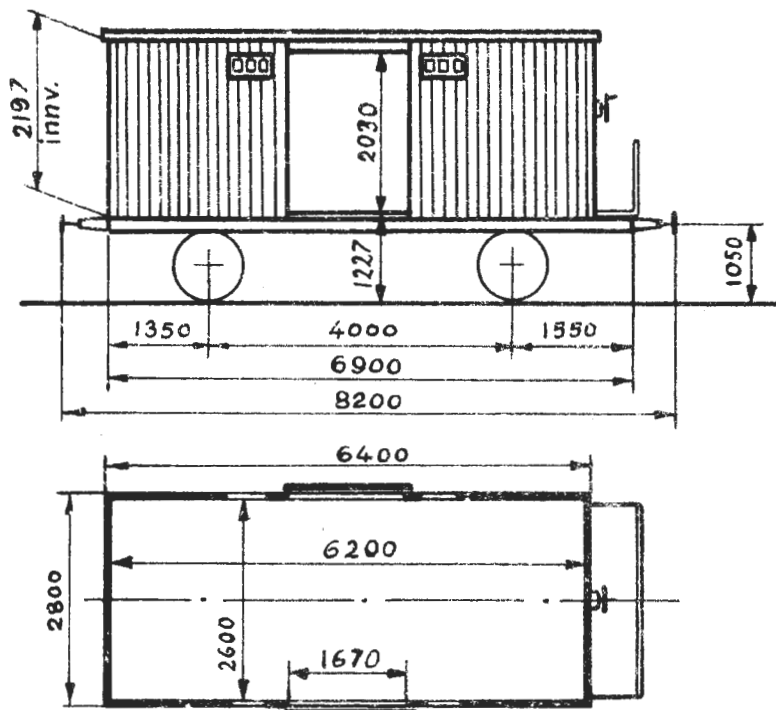

Bæreevne

A	B	C
16,0t	16,0t	

Omtrentlig vognvekt 8,0-8,5 t
 Gulvflate 16,1 m²
 Rominnhold 34,0 m³
 Hovedtegning 376 + skisse nr. 233

LUKKET GODSVOGN

Vogn nr.	Fabr.	Byggeår	Merknad	Vogn nr.	Fabr.	Byggeår	Merknad
3161	Str	19		10163	Str	17	
3164	"	"		10167	"	"	
3166	"	"		10168	"	"	
3167	"	"		10169	"	"	
3170	"	"		10172	"	"	
5097	Edf	16		10174	"	"	
5098	"	"		10176	"	"	
5100	"	"		10178	"	"	
5674	"	15		10181	"	"	
6119	Str	21		10182	"	"	
6121	"	"		10185	"	"	
6122	"	"		10187	"	"	
6129	"	"		10188	"	"	
6290	"	19		10198	"	19	
6291	"	"		10199	"	"	

Vogn nr.	Fabr.	Byggear	Merknad	Vogn nr.	Fabr.	Byggear	Merknad
10201	Str	19					
10202	"	"					
10206	"	"					
14090	Edf	16					
14092	"	"					
14099	"	"					
16551	Str	19					
16553	"	"					
17533	"	"					
17534	"	"					
20755	"	"					
20761	"	"					
23065	Skb	18					
23067	"	"					
23074	"	"					

Vogn nr.	Fabr.	Byggear	Merknad	Vogn nr.	Fabr.	Byggear	Merknad
40029	Skb	34/ 35		40064	Edf	34/ 35	
40030	"	"		40065	"	"	
40031	"	"		40066	"	"	
40032	"	"		40067	"	"	
40033	"	"		40068	"	"	
40034	"	"		40069	"	"	
40035	"	"					H-tegn. 3300 + 3570
40036	"	"		40070	Skb	34/ 35	
40037	"	"		40071	"	"	
40038	"	"		40072	"	"	
40039	"	"		40073	"	"	
40040	Str	"		40074	"	"	
40041	"	"		40075	"	"	
40042	"	"		40076	"	"	
40043	"	"		40077	"	"	
40044	"	"		40078	"	"	
40045	"	"		40079	"	"	
40046	"	"		40080	"	"	
40047	"	"		40081	"	"	
40048	"	"		40082	"	"	
40049	"	"		40083	"	"	
40050	"	"		40084	"	"	
40051	"	"		40085	Edf	"	
40052	"	"		40086	"	"	
40053	"	"		40087	"	"	
40054	"	"		40088	"	"	
40055	"	"		40089	"	"	
40056	"	"		40090	"	"	
40057	"	"		40091	"	"	
40058	"	"		40092	"	"	
40059	"	"		40093	"	"	
40060	Edf	"		40094	"	"	
40061	"	"					H-tegn. 3735 + 3570
40062	"	"		40095	Str	34/ 35	
40063	"	"					

Vogn nr.	Fabr.	Byggear	Merknad	Vogn nr.	Fabr.	Byggear	Merknad
40095	Str	34/35		40132	Edf	34/35	
40097	"	"		40133	"	"	
40098	"	"		40134	"	"	
40099	"	"		40135	"	"	
40100	"	"		40136	"	"	
40101	"	"		40137	"	"	
40102	"	"		40138	"	"	
40103	"	"		40139	"	"	
40104	"	"		40140	"	"	
40105	"	"		40141	"	"	
40106	"	"		40142	"	"	
40107	"	"		40143	"	"	
40108	"	"		40144	"	"	
40109	"	"		40145	Str	36	
40111	"	"		40146	"	"	
40112	"	"		40147	"	"	
40113	"	"		40148	"	"	
40114	"	"		40149	"	"	
40115	"	"		40150	"	"	
40116	"	"		40151	"	"	
40117	"	"		40152	"	"	
40118	"	"		40153	"	"	
40119	"	"		40154	"	"	
40120	Edf	"		40155	"	"	
40121	"	"		40156	"	"	
40122	"	"		40157	"	"	
40123	"	"		40158	"	"	
40124	"	"		40159	"	"	
40125	"	"		40160	"	"	
40127	"	"		40161	"	"	
40128	"	"		40162	"	"	
40129	"	"		40163	"	"	
40130	"	"		40164	"	"	
40131	"	"		40165	"	"	
				40166	"	"	

Vogn nr.	Fabr.	Byggeår	Merknad	Vogn nr.	Fabr.	Byggeår	Merknad
40308	Edf	38		40343	Str	38	
40309	"	"		40344	"	"	
40310	Str	"		40345	"	"	
40311	"	"		40346	"	"	
40312	"	"		40347	"	"	
40313	"	"		40348	"	"	
40314	"	"		40349	"	"	
40315	"	"		40350	"	"	
40316	"	"		40351	"	"	
40317	"	"		40352	"	"	
40318	"	"		40353	"	"	
40319	"	"		40354	"	"	
40320	"	"		40355	"	"	
40321	"	"		40356	"	"	
40322	"	"		40357	"	"	
40323	"	"		40358	"	"	
40324	"	"		40359	"	"	
40325	"	"		40360	Edf	"	
40326	"	"		40361	"	"	
40327	"	"		40362	"	"	1)
40328	"	"		40363	"	"	
40329	"	"		40364	"	"	
40330	"	"		40365	"	"	
40331	"	"		40366	"	"	
40332	"	"		40367	"	"	
40333	"	"		40368	"	"	
40334	"	"		40369	"	"	
40335	"	"		40370	"	"	
40336	"	"		40371	"	"	
40337	"	"		40372	"	"	
40338	"	"		40373	"	"	
40339	"	"		40374	"	"	1)
40340	"	"		40375	"	"	
40341	"	"		40376	"	"	
40342	"	"					

1) Innredet for sykkeltransport.

Trykk nr. 752 1.1.68

Vogn nr.	Fabr.	Byggeår	Merknad	Vogn nr.	Fabr.	Byggeår	Merknad
40377	Edf	38		40413	Str	39	
40378	"	"		40414	"	"	
40379	"	"		40415	"	"	
40380	"	"		40416	"	"	
40381	"	"		40417	"	"	
40382	"	"	1)	40418	"	"	
40383	"	"		40419	"	"	
40384	"	"		40420	"	"	
40385	Str	39		40421	"	"	
40386	"	"		40422	"	"	
40387	"	"		40423	"	"	
40388	"	"		40424	"	"	
40389	"	"		40425	"	"	
40390	"	"	1)	40426	"	"	
40391	"	"		40427	"	"	
40392	"	"		40428	"	"	3)
40393	"	"		40429	"	"	
40394	"	"		40430	"	"	
40395	"	"	2)	40431	"	"	
40396	"	"		40432	"	"	
40397	"	"		40433	"	"	
40398	"	"		40434	"	"	
40399	"	"		40435	Edf	"	
40400	"	"		40436	"	"	
40401	"	"		40437	"	"	
40402	"	"		40438	"	"	
40404	"	"	1)	40439	"	"	
40405	"	"		40440	"	"	
40406	"	"		40441	"	"	
40407	"	"		40442	"	"	
40408	"	"		40443	"	"	
40409	"	"		40444	"	"	
40410	"	"		40445	"	"	
40411	"	"		40446	"	"	
40412	"	"		40447	"	"	

1) Innredet for sykkeltransport. 2) Elektr. lys for tilkopl. til nabovg.
3) Innredet for banantransport.

Vogn nr.	Fabr.	Byggeår	Merknad	Vogn nr.	Fabr.	Byggeår	Merknad
40448	Edf	39		40482	Skb	40	
40449	"	"	1)	40483	"	41	
40450	"	"		40484	"	"	
40451	"	"		40485	"	"	
40452	"	"		40486	"	"	
40453	"	"		40487	"	"	
40454	"	"		40488	"	"	
40455	"	"	1)	40489	"	"	
40456	"	"	1)	40490	"	"	
40457	"	"		40491	"	"	
40458	"	"		40492	"	"	
40459	"	"		40493	"	"	
40460	Skb	40		40494	"	"	
40461	"	"		40495	"	"	
40462	"	"		40496	"	"	
40463	"	"		40497	"	"	
40464	"	"		40498	"	"	
40465	"	"	1)	40499	"	"	
40466	"	"		40500	"	"	
40467	"	"		40501	"	"	
40468	"	"		40502	"	"	
40469	"	"		40503	"	"	
40470	"	"		40504	"	"	
40471	"	"		40505	"	"	
40472	"	"		40506	"	"	
40473	"	"		40507	"	"	
40474	"	"		40508	"	"	
40475	"	"		40509	"	"	
40476	"	"		40510	Str	41	
40477	"	"		40511	"	"	
40478	"	"		40512	"	"	
40479	"	"		40513	"	"	
40480	"	"		40514	"	"	
40481	"	"		40515	"	"	

1) Innredet for sykkeltransport.

Vogn nr.	Fabr.	Byggeår	Merknad	Vogn nr.	Fabr.	Byggeår	Merknad
40516	Str	41		40551	Str	41	
40517	"	"		40552	"	"	
40518	"	"		40553	"	"	
40519	"	"		40554	"	"	
40520	"	"		40555	"	"	
40521	"	"		40556	"	"	
40522	"	"		40557	"	"	
40523	"	"		40558	"	"	
40524	"	"		40559	"	"	
40525	"	"		40560	"	"	
40526	"	"		40561	"	"	
40527	"	"		40562	"	"	
40528	"	"		40563	"	"	
40529	"	"	1)	40564	"	"	
40530	"	"		40565	"	"	
40531	"	"		40566	"	"	
40532	"	"		40567	"	"	
40533	"	"		40568	"	"	
40534	"	"		40569	"	"	
40535	"	"		40570	"	"	
40536	"	"		40571	"	"	
40537	"	"		40572	"	"	
40538	"	"		40573	"	"	
40539	"	"		40574	"	"	
40540	"	"		40575	"	"	
40541	"	"	1) 2)	40576	"	"	
40542	"	"		40577	"	"	
40543	"	"		40578	"	"	
40544	"	"		40579	"	"	
40545	"	"		40580	"	"	
40546	"	"	1)	40581	"	"	
40547	"	"		40582	"	"	
40548	"	"		40583	"	"	
40549	"	"		40584	"	"	
40550	"	"					

1) Innredet for sykkeltransport. 2) Akselavstand forandret til 7,2 m.

Vogn nr.	Fabr.	Byggear	Merknad	Vogn nr.	Fabr.	Byggear	Merknad
41004	Str	43		41039	Str	43	
41005	"	"		41040	"	"	
41006	"	"		41041	"	"	
41007	"	"		41042	"	"	
41008	"	"		41043	"	"	
41009	"	"		41044	"	"	
41010	"	"		41045	"	"	
41011	"	"		41046	"	"	
41012	"	"		41047	"	"	
41013	"	"		41048	"	"	
41014	"	"		41049	"	"	
41015	"	"		41050	"	"	
41016	"	"		41051	"	"	
41017	"	"		41052	"	"	
41018	"	"		41053	"	"	
41019	"	"		41054	"	"	
41020	"	"		41055	"	"	
41021	"	"		41056	"	"	
41022	"	"		41057	"	"	
41023	"	"		41058	"	"	
41024	"	"		41059	"	"	
41025	"	"		41060	"	"	
41026	"	"		41061	"	"	
41027	"	"		41062	"	"	
41028	"	"		41063	"	"	
41029	"	"		41064	"	"	
41030	"	"		41065	"	"	
41031	"	"		41066	"	"	
41032	"	"		41067	"	"	
41033	"	"		41068	"	"	
41034	"	"		41069	"	"	
41035	"	"		41070	"	"	
41036	"	"		41071	"	"	
41037	"	"		41072	"	"	
41038	"	"		41073	"	47	

Vogn nr.	Fabr.	Byggeår	Merknad	Vogn nr.	Fabr.	Byggeår	Merknad
41074	Str	47		41109	Str	47	
41075	"	"		41110	"	"	
41076	"	"		41111	"	"	
41077	"	"		41112	"	"	
41078	"	"		41113	"	"	
41079	"	"		41114	"	"	
41080	"	"		41115	"	"	
41081	"	"		41116	"	"	
41082	"	"		41117	"	"	
41083	"	"		41118	"	"	
41084	"	"		41119	"	"	
41085	"	"		41120	"	"	
41086	"	"		41121	"	"	
41087	"	"		41122	"	"	
41088	"	"		41123	Skb	48	
41089	"	"		41124	"	"	
41090	"	"		41125	"	"	
41091	"	"		41126	"	"	
41092	"	"		41127	"	"	
41093	"	"		41128	"	"	
41094	"	"		41129	"	"	
41095	"	"		41130	"	"	} Innredet for ostetransport
41096	"	"					
41097	"	"		41131	"	"	
41098	"	"		41132	"	"	
41099	"	"		41133	"	"	
41100	"	"		41134	"	"	
41101	"	"		41135	"	"	
41102	"	"		41136	"	"	
41103	"	"		41137	"	"	
41104	"	"		41138	"	"	
41105	"	"		41139	"	"	
41106	"	"		41140	"	"	
41107	"	"		41141	"	"	
41108	"	"		41142	"	"	

Vogn nr.	Fabr.	Byggear	Merknad	Vogn nr.	Fabr.	Byggear	Merknad
41143	Skb	48		41178	Skb	48	
41144	"	"		41179	"	"	
41145	"	"		41180	"	"	
41146	"	"		41181	"	"	
41147	"	"		41182	"	"	
41148	"	"		41183	"	"	
41149	"	"		41184	"	"	
41150	"	"		41185	"	"	
41151	"	"		41186	"	"	
41152	"	"		41187	"	"	
41153	"	"		41188	"	"	
41154	"	"		41189	"	"	
41155	"	"		41190	"	"	
41156	"	"		41191	"	49	
41157	"	"		41192	"	"	
41158	"	"		41193	"	"	
41159	"	"		41194	"	"	
41160	"	"		41195	"	"	
41161	"	"		41196	"	"	
41162	"	"		41197	"	"	
41163	"	"		41198	"	"	
41164	"	"		41199	"	"	
41165	"	"		41200	"	"	
41166	"	"		41201	"	"	
41167	"	"		41202	"	"	
41168	"	"		41203	"	"	
41169	"	"		41204	"	"	
41170	"	"		41205	"	"	
41171	"	"		41205	"	"	
41172	"	"		41206	"	"	
41173	"	"		41207	"	"	
41174	"	"		41208	"	"	
41175	"	"		41209	"	"	
41176	"	"		41210	"	"	
41177	"	"		41211	"	"	

Vogn nr.	Fabr.	Byggeår	Merknad	Vogn nr.	Fabr.	Byggeår	Merknad
41212	Skb	49		41246	Edf	49	1)
41213	"	"		41247	"	"	1) 2)
41214	"	"		41248	"	"	
41215	"	"		41249	"	"	
41216	"	"		41250	"	"	
41217	"	"		41251	"	"	
41218	"	"		41252	"	"	
41219	"	"		41253	"	"	
41220	"	"		41254	"	"	
41221	"	"		41255	"	"	
41222	"	"		41256	"	"	
41223	Edf	"		41257	"	"	
41224	"	"		41258	"	"	
41225	"	"		41259	"	"	
41226	"	"		41260	"	"	
41227	"	"		41261	"	"	
41228	"	"		41262	"	"	
41229	"	"		41263	"	"	3)
41230	"	"		41264	"	"	3)
41231	"	"		41265	"	"	
41232	"	"		41266	"	50	
41233	"	"		41267	"	"	
41234	"	"		41268	"	"	4)
41235	"	"		41269	"	"	4)
41236	"	"		41270	"	"	3)
41237	"	"		41271	"	"	
41238	"	"		41272	"	"	4)
41239	"	"		41273	"	48	
41240	"	"		41274	"	"	
41241	"	"		41275	"	"	
41242	"	"		41276	"	"	
41243	"	"		41277	"	"	
41244	"	"		41278	"	"	
41245	"	"	1)	41279	"	"	

- 1) Benyttes til transport av grønnsaker. Bæreevne 14,5-16,5 t, v.v. 13,5-14,0 t, gulvfl. 25,3-25,4 m², rominnhold 51,8-68,0 m³.
 2) Innredet som kjølevogn med kullsyreis. 3) Elektr. lys for tilkobling til nabovg. Dør og overgangslem i begge vognender.
 4) Elektr. lys for tilkobling til nabovg.

G4 type 1-vogner med internasjonal litrering og nummerering.

Vogn nr.	Fabr.	Byggear	Merknad	Vogn nr.	Fabr.	Byggear	Merknad
21 76 158 5023-7	Str	38	40386				
158 5025-2	"	39	40430				
158 5039-3	"	47	41185				
158 5044-3	Edf	48	41276				

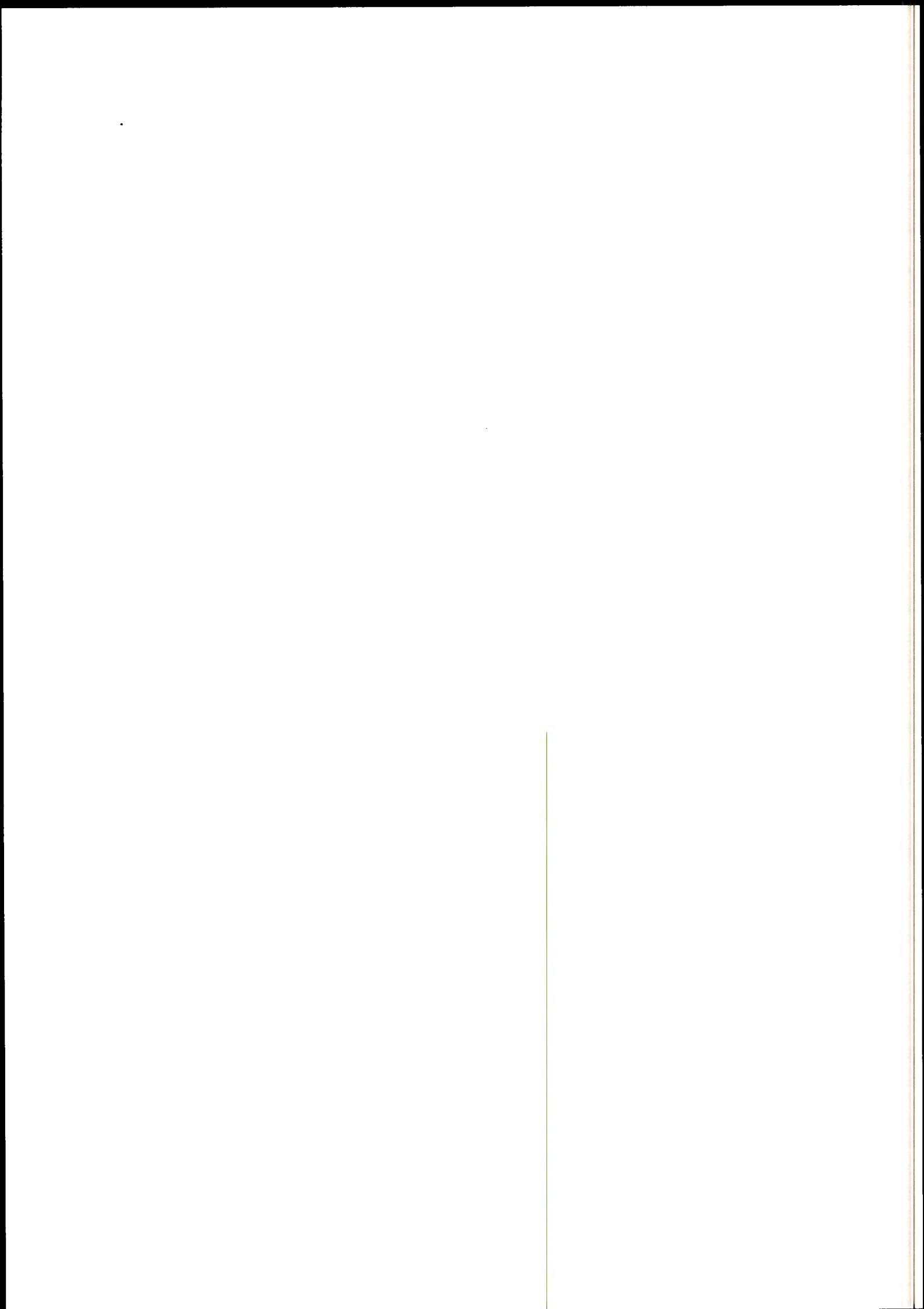

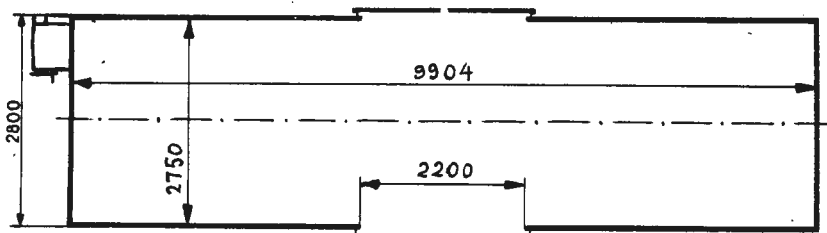
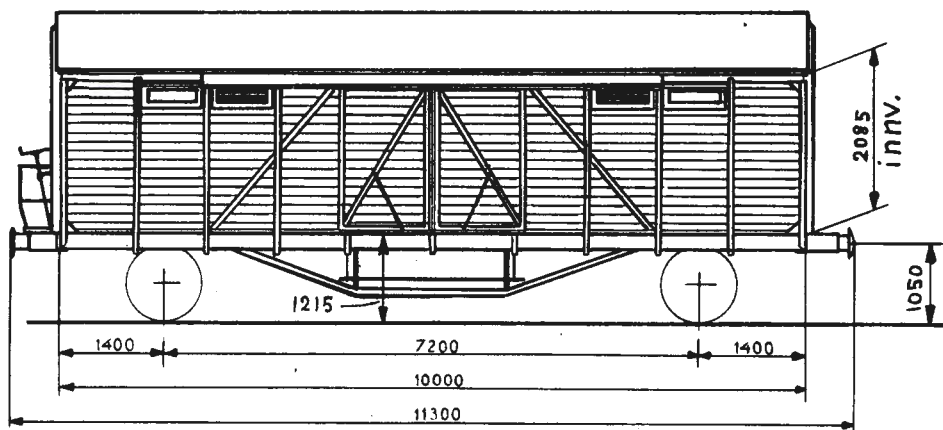

Höyde av dör-
öppning: 1927

Bæreevne

	A	B	C
	18,0t	18,0t	
S	12,0t		

Omtrentlig vognvekt 11,0-12,5 t
 Gulvflate 27,2 m²
 Rominnhold 74,0 m³
 Hovedtegning 6882

LUKKET GODSVOGN

Vogn nr.	Fabr.	Byggeår	Merknad	Vogn nr.	Fabr.	Byggeår	Merknad
42005	Edf	53		42020	Edf	53	
42006	"	"		42021	"	"	
42007	"	"		42022	"	"	
42008	"	"		42023	"	"	
42009	"	"		42024	"	"	
42010	"	"		42025	"	"	
42011	"	"		42026	"	"	
42012	"	"		42027	"	"	
42013	"	"		42028	"	"	
42014	"	"		42029	"	"	
42015	"	"		42030	Skb	"	
42016	"	"		42031	"	"	
42017	"	"		42032	"	"	
42018	"	"		42033	"	"	
42019	"	"		42034	"	"	

Vogn nr.	Fabr.	Byggear	Merknad	Vogn nr.	Fabr.	Byggear	Merknad
42035	Skb	53		42070	Skb	53	
42036	"	"		42071	"	"	
42037	"	"		42072	"	"	
42038	"	"		42073	"	"	
42039	"	"	1)	42074	"	"	
42040	"	"		42075	"	"	
42041	"	"		42076	"	"	
42042	"	"		42077	"	"	
42043	"	"		42078	"	"	
42044	"	"		42079	"	"	
42045	"	"		42080	"	"	
42046	"	"		42081	"	"	
42047	"	"		42082	"	"	
42048	"	"		42083	"	"	
42049	"	"		42084	"	"	
42050	"	"		42085	"	"	
42051	"	"		42086	"	54	
42052	"	"		42087	"	"	
42053	"	"		42088	"	"	
42054	"	"		42089	"	"	
42055	"	"		42090	"	"	
42056	"	"		42091	"	"	
42057	"	"		42092	"	"	
42058	"	"		42093	"	"	
42059	"	"		42094	"	"	
42060	"	"		42095	"	"	
42061	"	"		42096	"	"	
42062	"	"		42097	"	"	
42063	"	"		42098	"	"	
42064	"	"		42099	"	"	
42065	"	"		42100	"	"	
42066	"	"		42101	"	"	
42067	"	"		42102	"	"	
42068	"	"		42103	"	"	
42069	"	"		42104	"	"	

1) Elektr. lys for tilkopl. til nabovg.

Vogn nr.	Fabr.	Byggear	Merknad	Vogn nr.	Fabr.	Byggear	Merknad
42105	Skb	54		42140	Skb	55	
42106	"	"		42141	"	"	
42107	"	"		42142	"	"	
42108	"	"		42143	"	"	
42109	"	"		42144	"	56	
42110	"	"		42145	"	"	
42111	"	"		42146	"	"	
42112	"	"		42147	"	"	
42113	"	"		42148	"	"	
42114	"	"		42149	"	"	
42115	"	"		42150	"	"	
42116	"	"		42151	"	"	
42117	"	"		42152	"	"	
42118	"	"		42153	"	"	
42119	"	"		42154	"	"	
42120	"	"		42155	"	"	
42121	"	"		42156	"	"	
42122	"	"		42157	"	"	
42123	"	"		42158	"	"	
42124	"	"		42159	"	"	
42125	"	"		42160	"	"	
42126	"	"		42161	"	"	
42127	"	"		42162	"	"	
42128	"	"		42163	"	"	
42129	"	"		42164	"	"	
42130	"	55		42165	"	"	
42131	"	"		42166	"	"	
42132	"	"		42167	"	"	
42133	"	"		42168	"	"	
42134	"	"		42169	"	"	
42135	"	"		42170	"	"	
42136	"	"		42171	"	"	
42137	"	"		42172	"	"	
42138	"	"		42173	"	"	
42139	"	"		42174	"	"	

Vogn nr.	Fabr.	Byggear	Merknad	Vogn nr.	Fabr.	Byggear	Merknad
42175	Skb	56		42210	Str	53	
42176	"	"		42211	"	"	
42177	"	"		42212	"	"	
42178	"	"		42213	"	"	
42179	"	"		42214	"	"	
42180	Str	53		42215	"	"	
42181	"	"		42216	"	"	
42182	"	"		42217	"	"	
42183	"	"		42218	"	"	
42184	"	"		42219	"	"	
42185	"	"		42220	"	"	
42186	"	"		42221	"	"	
42187	"	"		42222	"	"	
42188	"	"		42223	"	"	
42189	"	"		42224	"	"	
42190	"	"		42225	"	54	
42191	"	"		42226	"	"	
42192	"	"		42227	"	"	
42193	"	"		42228	"	"	
42194	"	"		42229	"	"	
42195	"	"		42230	"	"	
42196	"	"		42231	"	"	
42197	"	"		42232	"	"	
42198	"	"		42233	"	"	
42199	"	"		42234	"	"	
42200	"	"		42235	"	"	
42201	"	"		42236	"	"	
42202	"	"		42237	"	"	
42203	"	"		42238	"	"	
42204	"	"		42239	"	"	
42205	"	"		42240	"	"	
42206	"	"		42241	"	"	
42207	"	"		42242	"	"	
42208	"	"		42243	"	"	
42209	"	"		42244	"	"	

Vogn nr.	Fabr.	Byggeår	Merknad	Vogn nr.	Fabr.	Byggeår	Merknad
42245	Str	54		42280	Str	54	
42246	"	"		42281	"	"	
42247	"	"		42282	"	"	
42248	"	"		42283	"	"	
42249	"	"		42284	"	"	
42250	"	"		42285	"	"	
42251	"	"		42286	"	"	
42252	"	"		42287	"	"	
42253	"	"		42288	"	"	
42254	"	"		42289	"	"	
42255	"	"		42290	"	"	
42256	"	"		42291	"	"	
42257	"	"		42292	"	"	
42258	"	"		42293	"	"	
42259	"	"		42294	"	"	
42260	"	"		42295	"	"	
42261	"	"		42296	"	"	
42262	"	"		42297	"	"	
42263	"	"		42298	"	"	
42264	"	"		42299	"	"	
42265	"	"		42300	"	"	
42266	"	"		42301	"	"	
42267	"	"		42302	"	"	
42268	"	"		42303	"	"	
42269	"	"		42304	"	"	
42270	"	"		42305	"	"	
42271	"	"		42306	"	"	
42272	"	"		42307	"	"	
42273	"	"		42308	"	"	
42274	"	"		42309	"	"	
42275	"	"		42310	"	"	
42276	"	"		42311	"	"	
42277	"	"		42312	"	"	
42278	"	"		42313	"	"	
42279	"	"		42314	"	"	

Vogn nr.	Fabr.	Byggeår	Merknad	Vogn nr.	Fabr.	Byggeår	Merknad
42315	Str	54		42350	Edf	55	
42316	"	"		42351	"	"	
42317	"	"		42352	"	"	
42318	"	"					
42319	"	"					
42320	"	"					
42321	"	"					
42322	"	"					
42323	"	"					
42324	"	"					
42325	"	"					
42326	"	"					
42327	"	"					
42328	"	55					
42329	"	"					
42330	Hök	53					
42331	"	"					
42332	"	"					
42333	"	"					
42334	"	"					
42335	"	"					
42336	"	"					
42337	"	"					
42338	"	"					
42339	"	"					
42340	"	"					
42341	"	"					
42342	"	"					
42343	Edf	54					
42344	"	55					
42345	"	"					
42346	"	"					
42347	"	"					
42348	"	"					
42349	"	"					

G4 type 2-vogner med internasjonal litrering og nummerering.

Vogn nr.	Fabr.	Byggeår	Merknad	Vogn nr.	Fabr.	Byggeår	Merknad
21 76 158 6004-6	Edf	53	42000	21 76 158 6330-5	Hök	53	42000
158 6034-3	Skb	"	42000	158 6340-4	Edf	55	42000
158 6074-9	"	"	42000				
158 6086-3	"	54	42000				
158 6104-4	"	"	42000				
158 6105-1	"	"	42000				
158 6106-9	"	"	42000				
158 6116-8	"	"	42000				
158 6122-6	"	"	42000				
158 6139-0	"	56	42000				
158 6177-0	Str	53	42000				
158 6201-8	"	"	42000				
158 6209-1	"	"	42000				
158 6224-0	"	54	42000				
158 6227-3	"	"	42000				
158 6237-2	"	"	42000				
158 6259-6	"	"	42000				
158 6261-2	"	"	42000				
158 6265-3	"	"	42000				
158 6266-1	"	"	42000				
158 6267-9	"	"	42000				
158 6274-5	"	"	42000				
158 6276-0	"	"	42000				
158 6278-6	"	"	42000				
158 6281-0	"	"	42000				
158 6282-8	"	"	42000				
158 6286-9	"	"	42000				
158 6289-3	"	"	42000				
158 6293-5	"	"	42000				
158 6301-6	"	"	42000				
158 6302-4	"	"	42000				
158 6310-7	"	"	42000				
158 6313-1	"	"	42000				
158 6314-9	"	"	42000				
158 6318-0	"	"	42000				

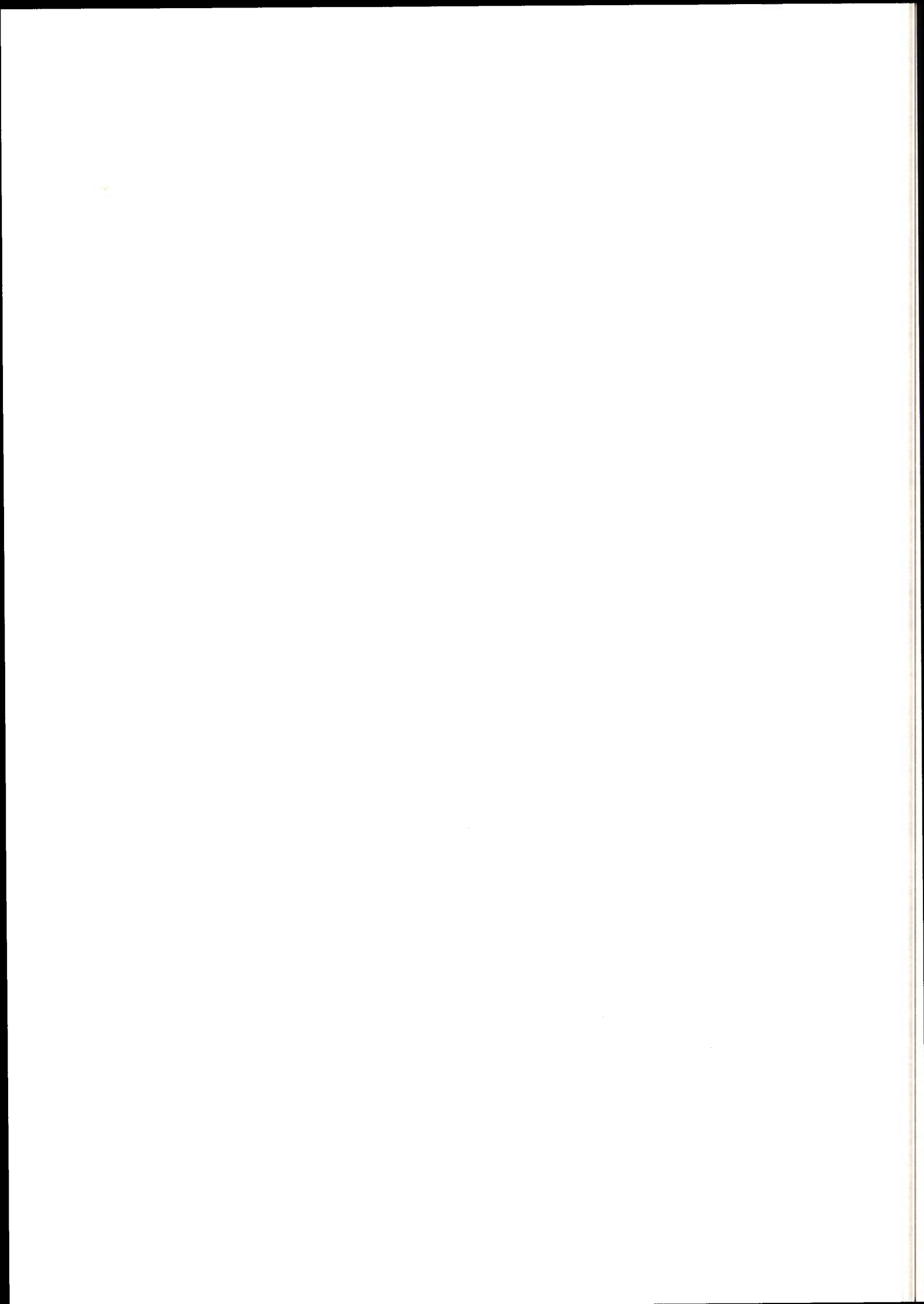

G5
TYPE 1

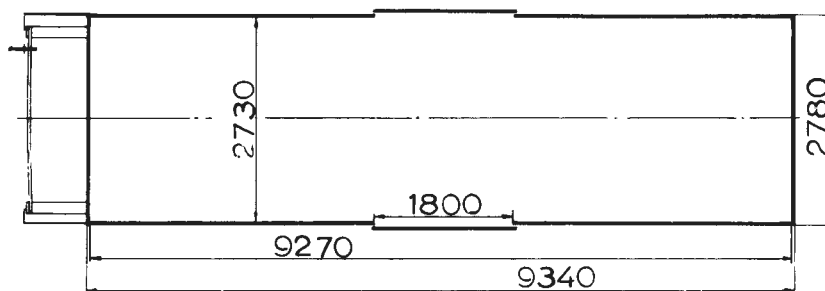
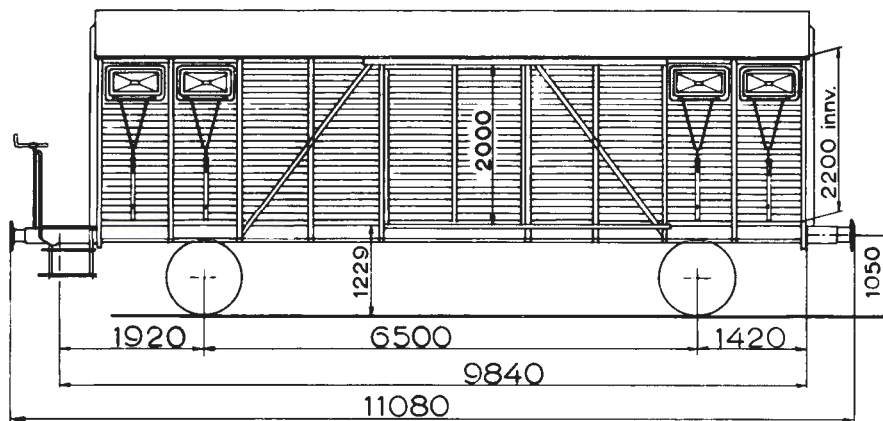

Bæreevne

	A	B	C
	20,5	21,0	
S	20,0		

Omtrentlig vognvekt 12,0-12,5 t
 Gulvflate 25,3 m²
 Rominnhold 64,0 m³
 Hovedtegning 7150

LUKKET GODSVOGN

Vogn nr.	Fabr.	Byggear	Merknad	Vogn nr.	Fabr.	Byggear	Merknad
43000	Edf	56		43015	Edf	57	
43001	"	"		43016	"	"	
43002	"	"		43017	"	"	
43003	"	"		43018	"	"	1)
43004	"	"		43019	"	"	
43005	"	"		43020	"	"	1)
43006	"	"		43021	"	"	1)
43007	"	"		43022	"	"	
43008	"	57		43023	"	"	1)
43009	"	"		43024	"	"	
43010	"	"		43025	"	"	1)
43011	"	"		43026	"	"	
43012	"	"		43027	"	"	1)
43013	"	"		43028	"	"	1)
43014	"	"		43029	"	"	

1) Bæreevne A: 19,5 t, B: 23,5 t, C: 27,5 t. Som S-vogn A: 19,5 t, BC: 23,5 t.

G5
TYPE 1

Vogn nr.	Fabr.	Byggeår	Merknad	Vogn nr.	Fabr.	Byggeår	Merknad
43030	Edf	57	1)				
43032	"	"					
43034	"	58					

1) Bæreevne A: 19,5 t, B: 23,5 t, C: 27,5 t. Som S-vogn A: 19,5 t, BC: 23,5 t.

G5 type 1-vogner med internasjonal litrering og nummerering.

Vogn nr.	Fabr.	Byggeår	Merknad	Vogn nr.	Fabr.	Byggeår	Merknad
21 76 120 0022-4	Edf	57					
120 0024-0	"	"	1)				
120 0026-5	"	"					
120 0031-5	"	"					
120 0033-1	"	58					

1) Bæreevne A: 19,5 t, B: 23,5 t, C: 27,5 t. Som S-vogn A: 19,5 t, BC: 23,5 t.

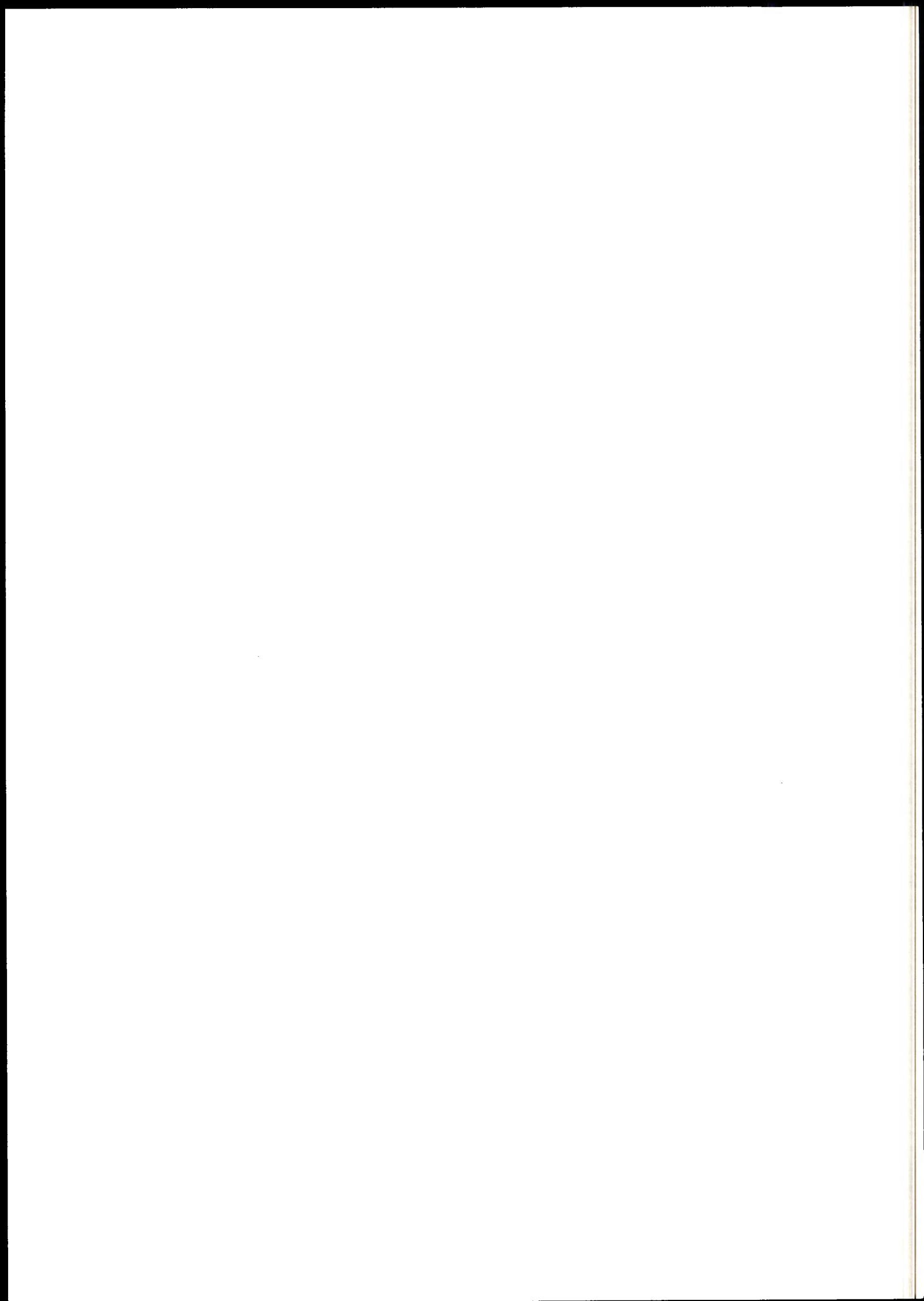

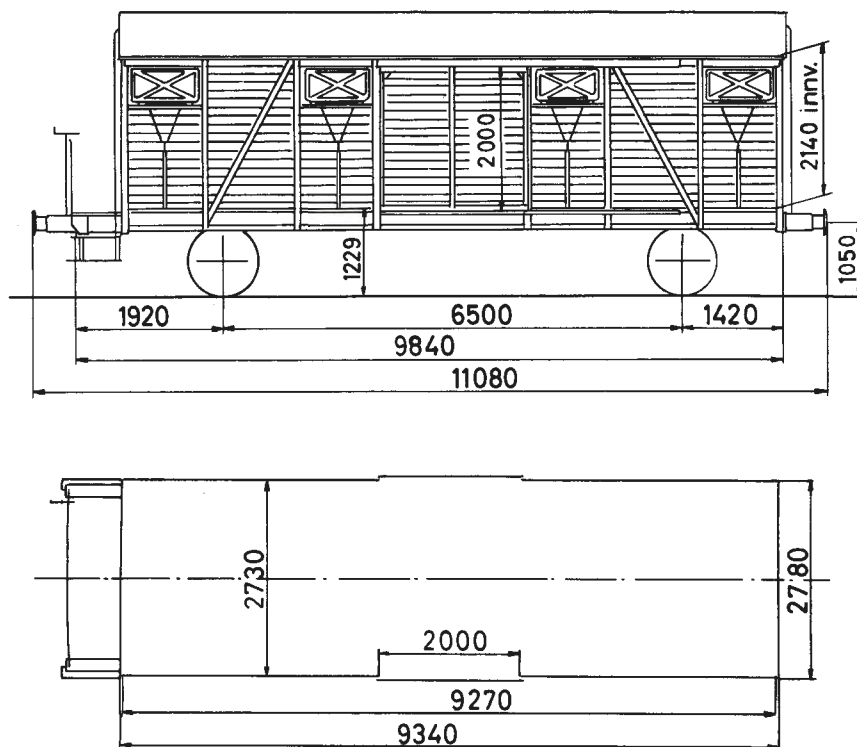

Vg.nr. 43035-43084,
43310-43312, 43360-43367:

Bæreevne

	A	B	C
	19,5 t	23,0t	
S	19,0 t	20,0t	

Omtrentlig vognvekt 12,0-13,0 t

Gulvflate 25,3 m²

Rominnhold 64,0 m³

Hovedtegning 8123

Vg.nr. 43085-43109:

Bæreevne

	A	B	C
	20,0t	23,5t	
S	19,5 t	20,0t	

Vg.nr. 43110:

Bæreevne

	A	B	C
	20,0t	24,0t	28,0t
S	20,0t	24,0t	

Vg.nr. 43111-43307:

Bæreevne

	A	B	C
	20,5t	24,0t	28,0t
S	20,5t	24,0t	

Vg.nr. 43313-43359,
43368-43409:

Bæreevne

	A	B	C
	19,5t	23,5t	27,5t
S	19,5t	23,5t	

LUKKET GODSVOGN

Vogn nr.	Fabr.	Byggear	Merknad	Vogn nr.	Fabr.	Byggear	Merknad
43035	Hök	58		43042	Hök	58	3)
43036	"	"	2)	43043	"	"	3)
43037	"	"		43044	"	"	
43038	"	"	3)	43045	"	"	
43039	"	"		43046	"	"	
43040	"	"		43047	"	"	
43041	"	"	1) 2)	43048	"	"	3)

1) Elektr. lys for tilkopl. til nabovg. 2) Innredet for sykkeltransport. 3) Har ballast.

Vogn nr.	Fabr.	Byggeår	Merknad	Vogn nr.	Fabr.	Byggeår	Merknad
43049	Hök	58		43084	Hök	59	
43050	"	"		43085	Edf	"	
43051	"	59		43086	"	"	
43052	"	"		43087	"	"	
43053	"	"		43088	"	"	
43054	"	"		43089	"	"	
43055	"	"	3)	43090	"	"	
43056	"	"		43091	"	"	
43057	"	"		43092	"	"	
43058	"	"		43093	"	"	
43059	"	"		43094	"	"	
43060	"	"		43095	"	"	
43061	"	"		43096	"	"	
43062	"	"		43097	"	"	
43063	"	"		43098	"	"	
43064	"	"		43099	"	"	
43065	"	"		43100	"	"	
43066	"	"		43101	"	"	
43067	"	"		43102	"	"	
43068	"	"		43103	"	"	
43069	"	"		43104	"	"	
43070	"	"		43105	"	"	
43071	"	"		43106	"	"	
43072	"	"		43107	"	"	
43073	"	"		43108	"	"	
43074	"	"		43109	"	"	
43075	"	"		43110	Str	60	
43076	"	"	3)	43111	"	"	
43077	"	"	2)	43112	"	"	
43078	"	"		43113	"	"	
43079	"	"		43114	"	"	
43080	"	"		43115	"	"	
43081	"	"		43116	"	"	
43082	"	"		43117	"	"	
43083	"	"		43118	"	"	

2) Innredet for sykkeltransport. 3) Har ballast.

Vogn nr.	Fabr.	Byggeår	Merknad	Vogn nr.	Fabr.	Byggeår	Merknad
43119	Str	60		43154	Str	61	
43120	"	"		43155	"	"	
43121	"	"		43156	"	"	
43122	"	"		43157	"	"	
43123	"	"		43158	"	"	
43124	"	"		43159	"	"	
43125	"	"		43160	"	"	
43126	"	"		43161	"	"	
43127	"	"		43162	"	"	
43128	"	"		43163	"	"	
43129	"	"		43164	"	"	
43130	"	61		43165	"	"	
43131	"	"		43166	"	"	
43132	"	"		43167	"	"	
43133	"	"		43168	"	"	
43134	"	"		43169	"	"	
43135	"	"		43170	"	"	
43136	"	"		43171	"	"	
43137	"	"		43172	"	"	
43138	"	"		43173	"	"	
43139	"	"		43174	"	"	
43140	"	"		43175	"	"	
43141	"	"		43176	"	"	
43142	"	"		43177	"	"	
43143	"	"		43178	"	"	
43144	"	"		43179	"	"	
43145	"	"		43180	"	"	
43146	"	"		43181	"	"	
43147	"	"		43182	"	"	
43148	"	"		43183	"	"	
43149	"	"		43184	"	"	
43150	"	"		43185	"	"	
43151	"	"		43186	"	"	
43152	"	"		43187	"	"	
43153	"	"		43188	"	"	

Vogn nr.	Fabr.	Byggear	Merknad	Vogn nr.	Fabr.	Byggear	Merknad
43189	Str	61		43224	Str	61	
43190	"	"		43225	"	"	
43191	"	"		43226	"	"	
43192	"	"		43227	"	"	
43193	"	"		43228	"	"	
43194	"	"		43229	"	"	
43195	"	"		43230	"	"	
43196	"	"		43231	"	"	
43197	"	"		43232	"	"	
43198	"	"		43233	"	"	
43199	"	"		43234	"	"	
43200	"	"		43235	"	"	
43201	"	"		43236	"	"	
43202	"	"		43237	"	"	
43203	"	"		43238	"	"	
43204	"	"		43239	"	"	
43205	"	"		43240	"	"	
43206	"	"		43241	"	"	
43207	"	"		43242	"	"	
43208	"	"		43243	"	"	
43209	"	"		43244	"	"	
43210	"	"		43245	"	"	
43211	"	"		43246	"	"	
43212	"	"		43247	"	"	
43213	"	"		43248	"	"	
43214	"	"		43249	"	"	
43215	"	"		43250	"	"	
43216	"	"		43251	"	"	
43217	"	"		43252	"	"	
43218	"	"		43253	"	"	
43219	"	"		43254	"	"	
43220	"	"		43255	"	"	
43221	"	"		43256	"	"	
43222	"	"		43257	"	"	
43223	"	"		43258	"	"	

Vogn nr.	Fabr.	Byggear	Merknad	Vogn nr.	Fabr.	Byggear	Merknad
43259	Str	61		43294	Str	62	
43260	"	62		43295	"	"	
43261	"	"		43296	"	"	
43262	"	"		43297	"	"	
43263	"	"		43298	"	"	
43264	"	"		43299	"	"	
43265	"	"		43300	"	"	
43266	"	"		43301	"	"	
43267	"	"		43302	"	"	
43268	"	"		43303	"	"	
43269	"	"		43304	"	"	
43270	"	"		43305	"	"	
43271	"	"		43306	"	"	
43272	"	"		43307	"	64	
43273	"	"		43310	Edf	60	
43274	"	"		43311	"	"	
43275	"	"		43312	"	"	
43276	"	"		43313	"	"	
43277	"	"		43314	"	"	
43278	"	"		43315	"	"	
43279	"	"		43316	"	"	
43280	"	"		43317	"	"	
43281	"	"		43318	"	"	
43282	"	"		43319	"	"	
43283	"	"		43320	"	"	
43284	"	"		43321	"	"	
43285	"	"		43322	"	"	
43286	"	"		43323	"	"	
43287	"	"		43324	"	"	
43288	"	"		43325	"	"	
43289	"	"		43326	"	"	
43290	"	"		43327	"	"	
43291	"	"		43328	"	"	
43292	"	"		43329	"	"	
43293	"	"		43330	"	"	
				43331	"	"	

Vogn nr.	Fabr.	Byggeår	Merknad	Vogn nr.	Fabr.	Byggeår	Merknad
43332	Edf	60		43367	Hök	60	
43333	"	"		43368	"	"	
43334	"	"		43369	"	"	
43335	"	"		43370	"	"	
43336	"	"		43371	"	"	
43337	"	"		43372	"	"	
43338	"	"		43373	"	"	
43339	"	"		43374	"	"	
43340	"	"		43375	"	"	
43341	"	"		43376	"	"	
43342	"	61		43377	"	"	
43343	"	"		43378	"	"	
43344	"	"		43379	"	"	
43345	"	"		43380	"	"	1) 2)
43346	"	"		43381	"	"	
43347	"	"		43382	"	"	
43348	"	"		43383	"	"	
43349	"	"		43384	"	"	
43350	"	"		43385	"	"	
43351	"	"		43386	"	"	
43352	"	"		43387	"	"	
43353	"	"		43388	"	"	
43354	"	"		43389	"	"	
43355	"	"		43390	"	"	
43356	"	"		43391	"	"	
43357	"	"		43392	"	"	
43358	"	"		43393	"	"	
43359	"	"		43394	"	"	
43360	Hök	60		43395	"	"	
43361	"	"		43396	"	"	
43362	"	"		43397	"	"	
43363	"	"		43398	"	"	
43364	"	"		43399	"	"	1) 2)
43365	"	"		43400	"	"	
43366	"	"		43401	"	"	

1) Elektr. lys for tilkopl. til nabovogn. 2) Innredet for sykkeltransport.

Vogn nr.	Fabr.	Byggeår	Merknad	Vogn nr.	Fabr.	Byggeår	Merknad
43402	Hök	60					
43403	"	"					
43404	"	"					
43405	"	"					
43406	"	"					
43407	"	"					
43408	"	"					
43409	"	"					

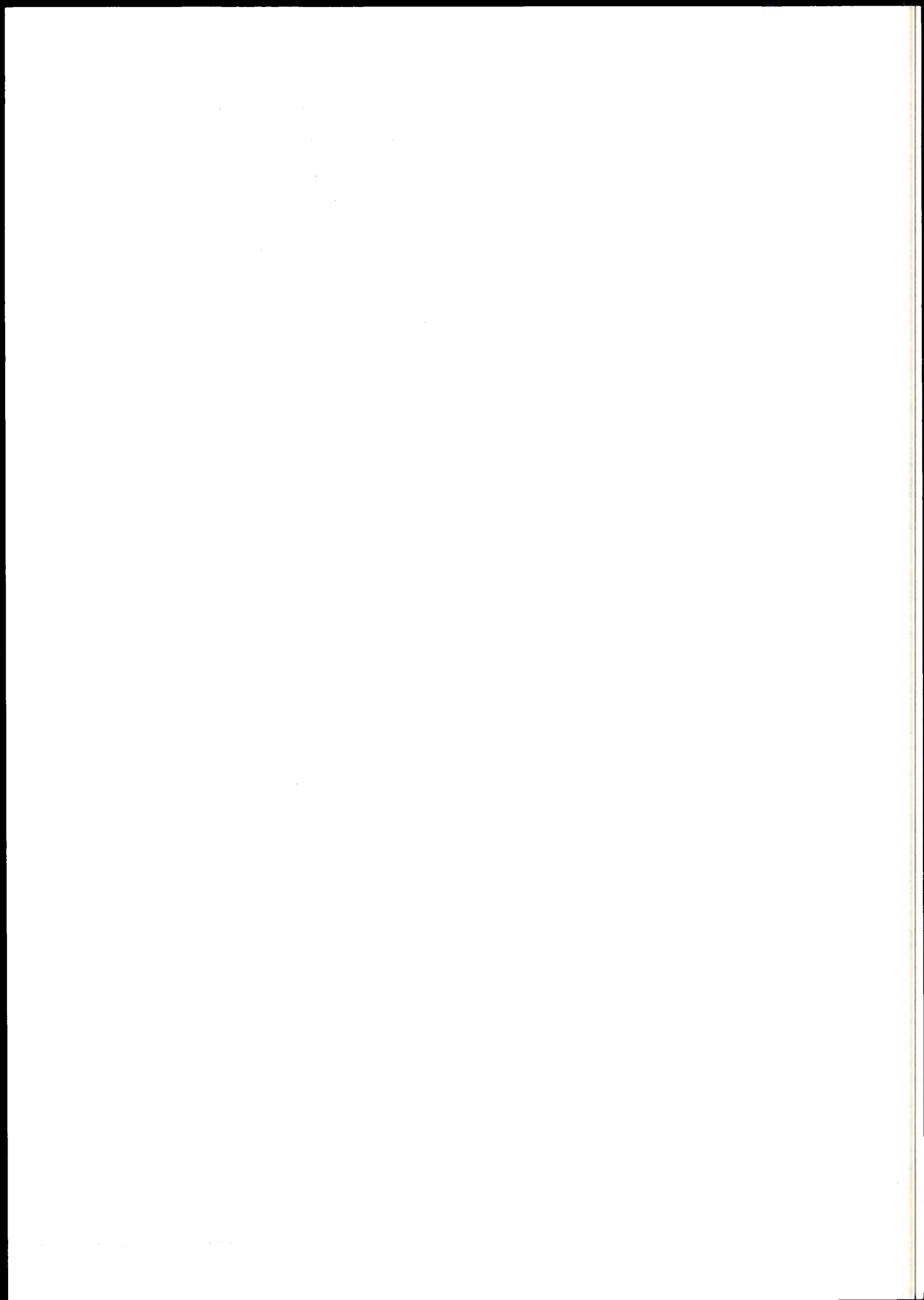

G5 type 2-vogner med internasjonal litrering og nummerering.

Vogn nr.	Fabr.	Byggeår	Merknad	Vogn nr.	Fabr.	Byggeår	Merknad
21 76 131 0001-5	Hök	58	2)				
131 0013-0	"	"	3)				
131 0018-9	"	59					
131 0029-6	"	"					
131 0030-4	"	"					
131 0034-6	"	"	3)				

2) Innredet for sykkeltransport. 3) Har ballast.

Gs

G5 type 2-vogner med internasjonal litrering og nummerering.

Vogn nr.	Fabr.	Byggeår	Merknad	Vogn nr.	Fabr.	Byggeår	Merknad
21 76 120 1026-4	Str	60		21 76 120 1077-7	Str	61	
120 1028-0	"	"		120 1078-5	"	"	
120 1029-8	"	"		120 1080-1	"	"	
120 1031-4	"	"		120 1081-9	"	"	
120 1032-2	"	"		120 1082-7	"	"	
120 1033-0	"	"		120 1083-5	"	"	
120 1034-8	"	"		120 1084-3	"	"	
120 1036-3	"	"		120 1086-8	"	"	
120 1042-1	"	"		120 1087-6	"	"	
120 1043-9	"	"		120 1088-4	"	"	
120 1044-7	"	"		120 1089-2	"	"	
120 1045-4	"	61		120 1090-0	"	"	
120 1046-2	"	"		120 1091-8	"	"	
120 1047-0	"	"		120 1092-6	"	"	
120 1048-8	"	"		120 1094-2	"	"	
120 1050-4	"	"		120 1095-9	"	"	
120 1051-2	"	"		120 1096-7	"	"	
120 1052-0	"	"		120 1097-5	"	"	
120 1053-8	"	"		120 1098-3	"	"	
120 1054-6	"	"		120 1099-1	"	"	
120 1055-3	"	"		120 1100-7	"	"	
120 1056-1	"	"		120 1102-3	"	"	
120 1058-7	"	"		120 1103-1	"	"	
120 1064-5	"	"		120 1104-9	"	"	
120 1065-2	"	"		120 1105-6	"	"	
120 1066-0	"	"		120 1106-4	"	"	
120 1068-6	"	"		120 1107-2	"	"	
120 1069-4	"	"		120 1109-8	"	"	
120 1070-2	"	"		120 1110-6	"	"	
120 1071-0	"	"		120 1111-4	"	"	
120 1072-8	"	"		120 1112-2	"	"	
120 1073-6	"	"		120 1114-8	"	"	
120 1074-4	"	"		120 1115-5	"	"	
120 1075-1	"	"		120 1116-3	"	"	
120 1076-9	"	"		120 1117-1	"	"	

G5 type 2-vogner med internasjonal litrering og nummerering.

Vogn nr.	Fabr.	Byggeår	Merknad	Vogn nr.	Fabr.	Byggeår	Merknad
21 76 120 1118-9	Str	61		21 76 120 1315-1	Hök	60	
120 1121-3	"	"		120 1319-3	"	"	
120 1122-1	"	"		120 1320-1	"	"	
120 1125-4	"	"					
120 1126-2	"	"					
120 1127-0	"	"					
120 1128-8	"	"					
120 1132-0	"	"					
120 1141-1	"	"					
120 1142-9	"	"					
120 1148-6	"	"					
120 1225-2	Edf	60	43312				
120 1230-2	"	"	43312				
120 1242-7	"	"	11112				
120 1243-5	"	"	11370				
120 1252-6	"	"					
120 1254-2	"	"					
120 1255-9	"	61					
120 1256-7	"	"					
120 1258-3	"	"					
120 1260-9	"	"					
120 1263-3	"	"					
120 1265-8	"	"					
120 1268-2	"	"					
120 1269-0	"	"					
120 1270-8	"	"					
120 1271-6	"	"					
120 1272-4	"	"					
120 1285-6	Hök	60					
120 1289-8	"	"					
120 1290-6	"	"					
120 1292-2	"	"					
120 1303-7	"	"					
120 1308-6	"	"					
120 1311-0	"	"					

G 5
TYPE 3

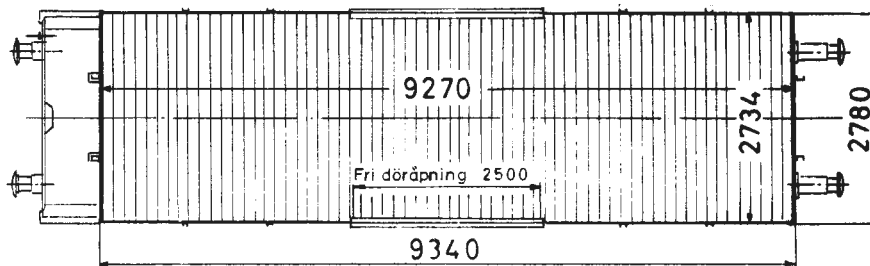
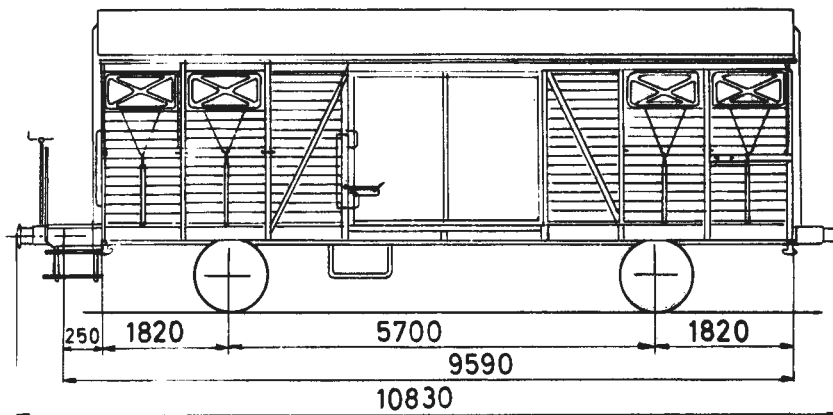

Bæreevne

	A	B	C
	19,5 t	23,5 t	27,5 t
S	19,5 t	23,5 t	

Omtrentlig vognvekt 12,0 t

Gulvflate 25,3 m²

Rominnhold 64,0 m³

Hovedtegning 12994

LUKKET GODSVOGN

Vogn nr.	Fabr.	Byggeår	Merknad	Vogn nr.	Fabr.	Byggeår	Merknad
43410	Str	63		43424	Str	63	
43411	"	"		43425	"	"	
43412	"	"		43426	"	"	
43413	"	"		43427	"	"	
43414	"	"		43428	"	"	
43415	"	"		43429	"	"	
43416	"	"		43430	"	"	
43417	"	"		43431	"	"	
43418	"	"		43432	"	"	
43419	"	"		43433	"	"	
43420	"	"		43434	"	"	
43421	"	"		43435	"	"	
43422	"	"		43436	"	"	
43423	"	"		43437	"	"	

Vogn nr.	Fabr.	Byggeår	Merknad	Vogn nr.	Fabr.	Byggeår	Merknad
43438	Str	63		43473	Str	63	
43439	"	"		43474	"	"	
43440	"	"		43475	"	"	
43441	"	"		43476	"	"	
43442	"	"		43477	"	"	
43443	"	"		43478	"	"	
43444	"	"		43479	"	"	
43445	"	"		43480	"	"	
43446	"	"		43481	"	"	
43447	"	"		43482	"	"	
43448	"	"		43483	"	"	
43449	"	"		43484	"	"	
43450	"	"		43485	"	"	
43451	"	"		43486	"	"	
43452	"	"		43487	"	"	
43453	"	"		43488	"	"	
43454	"	"		43489	"	"	
43455	"	"		43490	"	"	
43456	"	"		43491	"	"	
43457	"	"		43492	"	"	
43458	"	"		43493	"	"	
43459	"	"		43494	"	"	
43460	"	"		43495	"	"	
43461	"	"		43496	"	"	
43462	"	"		43497	"	"	
43463	"	"		43498	"	"	
43464	"	"		43499	"	"	
43465	"	"		43500	"	"	
43466	"	"		43501	"	"	
43467	"	"		43502	"	"	
43468	"	"		43503	"	"	
43469	"	"		43504	"	"	
43470	"	"		43505	"	"	
43471	"	"		43506	"	"	
43472	"	"		43507	"	"	

Vogn nr.	Fabr.	Byggear	Merknad	Vogn nr.	Fabr.	Byggear	Merknad
43508	Str	63		43543	Str	63	
43509	"	"		43544	"	"	
43510	"	"		43545	"	"	
43511	"	"		43546	"	"	
43512	"	"		43547	"	"	
43513	"	"		43548	"	"	
43514	"	"		43549	"	"	
43515	"	"		43550	"	"	
43516	"	"		43551	"	"	
43517	"	"		43552	"	"	
43518	"	"		43553	"	"	
43519	"	"		43554	"	"	
43520	"	"		43555	"	"	
43521	"	"		43556	"	"	
43522	"	"		43557	"	"	
43523	"	"		43558	"	"	
43524	"	"		43559	"	"	
43525	"	"		43560	"	"	
43526	"	"		43561	"	"	
43527	"	"		43562	"	64	
43528	"	"		43563	"	"	
43529	"	"		43564	"	"	
43530	"	"		43565	"	"	
43531	"	"		43566	"	"	
43532	"	"		43567	"	"	
43533	"	"		43568	"	"	
43534	"	"		43569	"	"	
43535	"	"		43570	"	"	
43536	"	"		43571	"	"	
43537	"	"		43572	"	"	
43538	"	"		43573	"	"	
43539	"	"		43574	"	"	
43540	"	"		43575	"	"	
43541	"	"		43576	"	"	
43542	"	"		43577	"	"	

Vogn nr.	Fabr.	Byggeår	Merknad	Vogn nr.	Fabr.	Byggeår	Merknad
43578	Str	64					
43579	"	"					
43580	"	"					
43581	"	"					
43582	"	"					
43583	"	"					
43584	"	"					
43585	"	"					
43586	"	"					
43587	"	"					
43588	"	"					
43589	"	"					
43590	"	"					
43591	"	"					
43592	"	"					
43593	"	"					
43594	"	"					
43595	"	"					
43596	"	"					
43597	"	"					
43598	"	"					
43599	"	"					
43600	"	"					
43601	"	"					
43602	"	"					
43603	"	"					
43604	"	"					
43605	"	"					
43606	"	"					
43607	"	"					
43608	"	"					
43609	"	"					

G5 type 3-vogner med internasjonal litrering og nummerering.

Vogn nr.	Fabr.	Byggeår	Merknad	Vogn nr.	Fabr.	Byggeår	Merknad
21 76 120 2003-2	Str	63		21 76 120 2074-3	Str	63	
120 2004-0	"	"		120 2075-0	"	"	
120 2006-5	"	"		120 2076-8	"	"	
120 2008-1	"	"		120 2077-6	"	"	
120 2014-9	"	"		120 2078-4	"	"	
120 2017-2	"	"		120 2080-0	"	"	
120 2019-8	"	"		120 2081-8	"	"	
120 2021-4	"	"		120 2082-6	"	"	
120 2031-3	"	"		120 2083-4	"	"	
120 2034-7	"	"		120 2084-2	"	"	
120 2035-4	"	"		120 2085-9	"	"	
120 2036-2	"	"		120 2086-7	"	"	
120 2042-0	"	"		120 2087-5	"	"	
120 2045-3	"	"		120 2088-3	"	"	
120 2047-9	"	"		120 2089-1	"	"	
120 2049-5	"	"		120 2091-7	"	"	
120 2051-1	"	"		120 2092-5	"	"	
120 2052-9	"	"		120 2093-3	"	"	
120 2054-5	"	"		120 2094-1	"	"	
120 2055-2	"	"		120 2095-8	"	"	
120 2057-8	"	"		120 2096-6	"	"	
120 2058-6	"	"		120 2097-4	"	"	
120 2059-4	"	"		120 2098-2	"	"	
120 2061-0	"	"		120 2099-0	"	"	
120 2062-8	"	"		120 2100-6	"	"	
120 2063-6	"	"		120 2101-4	"	"	
120 2065-1	"	"		120 2102-2	"	"	
120 2066-9	"	"		120 2104-8	"	"	
120 2067-7	"	"		120 2105-5	"	"	
120 2068-5	"	"		120 2106-3	"	"	
120 2069-3	"	"		120 2107-1	"	"	
120 2070-1	"	"		120 2108-9	"	"	
120 2071-9	"	"		120 2109-7	"	"	
120 2072-7	"	"		120 2110-5	"	"	
120 2073-5	"	"		120 2111-3	"	"	

G5 type 3-vogner med internasjonal litrering og nummerering.

Vogn nr.	Fabr.	Byggear	Merknad	Vogn nr.	Fabr.	Byggear	Merknad
21 76 120 2112-1	Str	63					
120 2113-9	"	"					
120 2114-7	"	"					
120 2119-6	"	"					
120 2121-2	"	"					
120 2122-0	"	"					
120 2123-8	"	"					
120 2125-3	"	"					
120 2126-1	"	"					
120 2128-7	"	"					
120 2130-3	"	"					
120 2132-9	"	"					
120 2134-5	"	"					
120 2135-2	"	"					
120 2138-6	"	"					
120 2150-1	"	"					
120 2178-2	"	64	13588				
120 2163-4	"	"	13573				

G5
TYPE 4

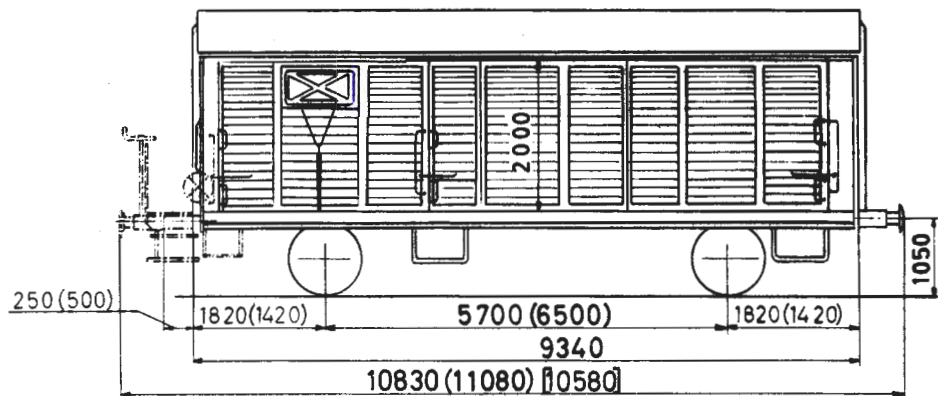

Mål i () gjelder for
vg.nr. 44000 og 44001.

F.o.m. vogn nr. 44502(2176 210 2502-2)
er bremserpl.form sløyfet. Disse
vg.har skruebremse med ratt v/
hver vognside. Mål i [] gjelder
vogner u/ bremserpl.form.

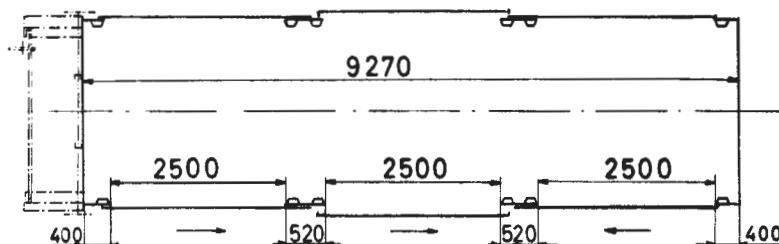

Vg.nr. 44000 og 44001 :

Bæreevne

	A	B	C
	20,0t	23,5t	27,5t
S	20,0t	23,5t	

F.o.m. vg. nr. 44402 ²⁾:

Bæreevne

	A	B	C
	19,5t	23,5t	27,5t
S	19,5t	23,5t	

Omtrentlig vognvekt 12,0-12,5t

Gulvflate 25,2m²

Rominhold 64,0m³

Hovedtegning 14511 / 18890

LUKKET GODSVOGN

Vogn nr.	Fabr.	Byggeår	Merknad	Vogn nr.	Fabr.	Byggeår	Merknad
44000	Str	62	1)	44015	Str	64	
44001	"	"	1)	44016	"	"	
44002	"	64		44017	"	"	
44003	"	"		44018	"	"	
44004	"	"		44019	"	"	
44005	"	"		44020	"	"	
44006	"	"		44021	"	"	
44007	"	"		44022	"	"	
44008	"	"		44023	"	"	
44009	"	"		44024	"	"	
44010	"	"		44025	"	"	
44011	"	"		44026	"	"	
44012	"	"		44027	"	"	
44013	"	"		44028	"	"	
44014	"	"		44029	"	"	

1) Bygget som prøvevogn. 2) Vogner med plasttak har bæreevne: A: 20,0t (vg. 44120 og 44122 har 20,5t), B: 24,0t, C: 28,0t. Som S-vg.: A: 20,0t (vg. 44120 og 44122 har 20,5t), BC: 24,0t.

Vogn nr.	Fabr.	Byggear	Merknad	Vogn nr.	Fabr.	Byggear	Merknad
44310	Str	65	3)	44345	Str/ Hök	65	
44311	"	"	3)	44346	"	"	
44312	"	"	3)	44347	"	"	
44313	"	"	3)	44348	"	"	
44314	"	"	3)	44349	"	"	
44315	"	"	3)	44350	"	"	
44316	"	"	3)	44351	"	"	
44317	"	"	3)	44352	"	"	
44318	"	"	3)	44353	"	"	
44319	"	"	3)	44354	"	66	
44320	"	"	3)	44355	"	"	
44321	"	"	3)	44356	"	"	
44322	"	"	3)	44357	"	"	
44323	"	"	3)	44358	"	"	
44324	"	"	3)	44359	"	"	
44325	"	"	3)	44360	"	"	
44326	"	"	3)	44361	"	"	
44327	Str/ Hök	"		44362	"	"	
44328	"	"		44363	"	"	
44329	"	"		44364	"	"	
44330	"	"		44365	"	"	
44331	"	"		44366	"	"	
44332	"	"		44367	"	"	
44333	"	"		44368	"	"	
44334	"	"		44369	"	"	
44335	"	"		44370	"	"	
44336	"	"		44371	"	"	
44337	"	"		44372	"	"	
44338	"	"		44373	"	"	
44339	"	"		44374	"	"	
44340	"	"		44375	"	"	
44341	"	"		44376	"	"	
44342	"	"		44377	"	"	
44343	"	"		44378	"	"	
44344	"	"		44379	"	"	

3) Har plasttak.

Vogn nr.	Fabr.	Byggear	Merknad	Vogn nr.	Fabr.	Byggear	Merknad
44427	Str/ Edf	65		44462	Str/ Edf	66	
44428	"	"		44463	"	"	
44429	"	"		44464	"	"	
44430	"	"		44465	"	"	
44431	"	"		44466	"	"	
44432	"	"		44467	"	"	
44433	"	"		44468	"	"	
44434	"	"		44469	"	"	
44435	"	"		44470	"	"	
44436	"	"					
44437	"	"					
44438	"	"					
44439	"	"					
44440	"	"					
44441	"	"					
44442	"	"					
44443	"	"					
44444	"	"					
44445	"	"					
44446	"	"					
44447	"	"					
44448	"	"					
44449	"	"					
44450	"	"					
44451	"	66					
44452	"	"					
44453	"	"					
44454	"	"					
44455	"	"					
44456	"	"					
44457	"	"					
44458	"	"					
44459	"	"					
44460	"	"					
44461	"	"					

G5 type 4-vogner med internasjonal litrering og nummerering.

Vogn nr.	Fabr.	Byggeår	Merknad	Vogn nr.	Fabr.	Byggeår	Merknad
21 76 210 2334-0	Str/ Hök	65		21 76 210 2414-0	Str/ Hök	66	
210 2380-3	"	66		210 2414-0	"	"	
210 2381-1	"	"		210 2415-7	"	"	
210 2382-9	"	"		210 2416-5	"	"	
210 2383-7	"	"		210 2417-3	"	"	
210 2384-5	"	"		210 2418-1	"	"	
210 2385-2	"	"		210 2419-9	"	"	
210 2386-0	"	"		210 2420-7	"	"	
210 2387-8	"	"		210 2421-5	"	"	
210 2388-6	"	"		210 2422-3	"	"	
210 2389-4	"	"		210 2423-1	"	"	
210 2390-2	"	"		210 2424-9	"	"	
210 2391-0	"	"		210 2425-6	"	"	
210 2392-8	"	"		210 2426-4	"	"	
210 2393-6	"	"		210 2471-0	Str/ Edf	"	
210 2394-4	"	"		210 2472-8	"	"	
210 2395-1	"	"		210 2473-6	"	"	
210 2396-9	"	"		210 2474-4	"	"	
210 2397-7	"	"		210 2475-1	"	"	
210 2398-5	"	"		210 2476-9	"	"	
210 2399-3	"	"		210 2477-7	"	"	
210 2400-9	"	"		210 2478-5	"	"	
210 2401-7	"	"		210 2479-3	"	"	
210 2402-5	"	"		210 2480-1	"	"	
210 2403-3	"	"		210 2481-9	"	"	
210 2404-1	"	"		210 2482-7	"	"	
210 2405-8	"	"		210 2483-5	"	"	
210 2406-6	"	"		210 2484-3	"	"	
210 2407-4	"	"		210 2485-0	"	"	
210 2408-2	"	"		210 2486-8	"	"	
210 2409-0	"	"		210 2487-6	"	"	
210 2410-8	"	"		210 2488-4	"	"	
210 2411-6	"	"		210 2489-2	"	"	
210 2412-4	"	"		210 2490-0	"	"	
210 2413-2	"	"		210 2491-8	"	"	

His

G5 type 4-vogner med internasjonal litrering og nummerering.

Vogn nr.	Fabr.	Byggeår	Merknad	Vogn nr.	Fabr.	Byggeår	Merknad
21 76 210 2492-6	Str/ Edf	66		21 76 210 2527-9	Str	66	
210 2493-4	"	"		210 2528-7	"	"	
210 2494-2	"	"		210 2529-5	"	"	
210 2495-9	"	"		210 2530-3	"	"	
210 2496-7	"	"		210 2531-1	"	"	
210 2497-5	"	"		210 2532-9	"	"	
210 2498-3	"	"		210 2533-7	"	"	
210 2499-1	"	"		210 2534-5	"	"	
210 2500-6	"	"		210 2535-2	"	"	
210 2501-4	"	"		210 2536-0	"	"	
210 2502-2	Str	"		210 2537-8	"	"	
210 2503-0	"	"		210 2538-6	"	"	
210 2504-8	"	"		210 2539-4	"	"	
210 2505-5	"	"		210 2540-2	"	"	
210 2506-3	"	"		210 2541-0	"	"	
210 2507-1	"	"		210 2542-8	"	"	
210 2508-9	"	"		210 2543-6	"	"	
210 2509-7	"	"		210 2544-4	"	"	
210 2510-5	"	"		210 2545-1	"	"	
210 2511-3	"	"		210 2546-9	"	"	
210 2512-1	"	"		210 2547-7	"	"	
210 2513-9	"	"		210 2548-5	"	"	
210 2514-7	"	"		210 2549-3	"	"	
210 2515-4	"	"		210 2550-1	"	"	
210 2516-2	"	"		210 2551-9	"	67	
210 2517-0	"	"		210 2552-7	"	"	
210 2518-8	"	"		210 2553-5	"	"	
210 2519-6	"	"		210 2554-3	"	"	
210 2520-4	"	"		210 2555-0	"	"	
210 2521-2	"	"		210 2556-8	"	"	
210 2522-0	"	"		210 2557-6	"	"	
210 2523-8	"	"		210 2558-4	"	"	
210 2524-6	"	"		210 2559-2	"	"	
210 2525-3	"	"		210 2560-0	"	"	
210 2526-1	"	"		210 2561-8	"	"	

G5 type 4-vogner med internasjonal litrering og nummerering.

Vogn nr.	Fabr.	Byggear	Merknad	Vogn nr.	Fabr.	Byggear	Merknad
21 76 210 2562-6	Str	67		21 76 210 2597-2	Str	67	
210 2563-4	"	"		210 2598-0	"	"	
210 2564-2	"	"		210 2599-8	"	"	
210 2565-9	"	"		210 2600-4	"	"	
210 2566-7	"	"		210 2601-2	"	"	
210 2567-5	"	"		210 2602-0	"	"	
210 2568-3	"	"		210 2603-8	"	"	
210 2569-1	"	"		210 2604-6	"	"	
210 2570-9	"	"		210 2605-3	"	"	
210 2571-7	"	"		210 2606-1	"	"	
210 2572-5	"	"		210 2607-9	"	"	
210 2573-3	"	"		210 2608-7	"	"	
210 2574-1	"	"		210 2609-5	"	"	
210 2575-8	"	"		210 2610-3	"	"	
210 2576-6	"	"		210 2611-1	"	"	
210 2577-4	"	"		210 2612-9	"	"	
210 2578-2	"	"		210 2613-7	"	"	
210 2579-0	"	"		210 2614-5	"	"	
210 2580-8	"	"		210 2615-2	"	"	
210 2581-6	"	"		210 2616-0	"	"	
210 2582-4	"	"		210 2617-8	"	"	
210 2583-2	"	"		210 2618-6	"	"	
210 2584-0	"	"		210 2619-4	"	"	
210 2585-7	"	"		210 2620-2	"	"	
210 2586-5	"	"		210 2621-0	"	"	
210 2587-3	"	"		210 2622-8	"	"	
210 2588-1	"	"		210 2623-6	"	"	
210 2589-9	"	"		210 2624-4	"	"	
210 2590-7	"	"		210 2625-1	"	"	
210 2591-5	"	"		210 2626-9	"	"	
210 2592-3	"	"		210 2627-7	"	"	
210 2593-1	"	"		210 2628-5	"	"	
210 2594-9	"	"		210 2629-3	"	"	
210 2595-6	"	"		210 2630-1	"	"	
210 2596-4	"	"		210 2631-9	"	"	

His

G5 type 4-vogner med internasjonal litrering og nummerering.

Vogn nr.	Fabr.	Byggeår	Merknad	Vogn nr.	Fabr.	Byggeår	Merknad
21 76 210 2632-7	Str	67		21 76 210 2667-3	Str	67	
210 2633-5	"	"		210 2668-1	"	"	
210 2634-3	"	"		210 2669-9	"	"	
210 2635-0	"	"		210 2670-7	"	"	
210 2636-8	"	"		210 2671-5	"	"	
210 2637-6	"	"		210 2672-3	"	"	
210 2638-4	"	"		210 2673-1	"	"	
210 2639-2	"	"		210 2674-9	"	"	
210 2640-0	"	"		210 2675-6	"	"	
210 2641-8	"	"		210 2676-4	"	"	
210 2642-6	"	"		210 2677-2	"	"	
210 2643-4	"	"		210 2678-0	"	"	
210 2644-2	"	"		210 2679-8	"	"	
210 2645-9	"	"		210 2680-6	"	"	
210 2646-7	"	"		210 2681-4	"	"	
210 2647-5	"	"		210 2682-2	"	"	
210 2648-3	"	"		210 2683-0	"	"	
210 2649-1	"	"		210 2684-8	"	"	
210 2650-9	"	"		210 2685-5	"	"	
210 2651-7	"	66	1)	210 2686-3	"	"	
210 2652-5	"	67		210 2687-1	"	"	
210 2653-3	"	"		210 2688-9	"	"	
210 2654-1	"	"		210 2689-7	"	"	
210 2655-8	"	"		210 2690-5	"	"	
210 2656-6	"	"		210 2691-3	"	"	
210 2657-4	"	"		210 2692-1	"	"	
210 2658-2	"	"		210 2693-9	"	"	
210 2659-0	"	"		210 2694-7	"	"	
210 2660-8	"	"		210 2695-4	"	"	
210 2661-6	"	"		210 2696-2	"	"	
210 2662-4	"	"		210 2697-0	"	"	
210 2663-2	"	"		210 2698-8	"	"	
210 2664-0	"	"		210 2699-6	"	"	
210 2665-7	"	"		210 2700-2	"	"	
210 2666-5	"	"		210 2701-0	"	"	

1) Bygget som prøvevogn med 2 dører på hver vognside. Har ikke skyvetak. Bæreevne A: 20,0 t, B: 24,0 t, C: 28,0 t. Som S-vogn A: 20,0 t, BC: 24,0 t.

G5 type 4-vogner med internasjonal litrering og nummerering.

Vogn nr.	Fabr.	Byggeår	Merknad	Vogn nr.	Fabr.	Byggeår	Merknad
21 76 210 2802-6	Hök	67		21 76 210 2837-2	Hök	67	
210 2803-4	"	"		210 2838-0	"	"	
210 2804-2	"	"		210 2839-8	"	"	
210 2805-9	"	"		210 2840-6	"	"	
210 2806-7	"	"		210 2841-4	"	"	
210 2807-5	"	"		210 2842-2	"	"	
210 2808-3	"	"		210 2843-0	"	"	
210 2809-1	"	"		210 2844-8	"	"	
210 2810-9	"	"		210 2845-5	"	"	
210 2811-7	"	"		210 2846-3	"	"	
210 2812-5	"	"		210 2847-1	"	"	
210 2813-3	"	"		210 2848-9	"	"	
210 2814-1	"	"		210 2849-7	"	"	
210 2815-8	"	"		210 2850-5	"	"	
210 2816-6	"	"		210 2851-3	"	"	
210 2817-4	"	"		210 2852-1	"	"	
210 2818-2	"	"		210 2853-9	"	"	
210 2819-0	"	"		210 2854-7	"	"	
210 2820-8	"	"		210 2855-4	"	"	
210 2821-6	"	"		210 2856-2	"	"	
210 2822-4	"	"		210 2857-0	"	"	
210 2823-2	"	"		210 2858-8	"	"	
210 2824-0	"	"		210 2859-6	"	"	
210 2825-7	"	"		210 2860-4	"	"	
210 2826-5	"	"		210 2861-2	"	"	
210 2827-3	"	"		210 2862-0	"	"	
210 2828-1	"	"		210 2863-8	"	"	
210 2829-9	"	"		210 2864-6	"	"	
210 2830-7	"	"		210 2865-3	"	"	
210 2831-5	"	"		210 2866-1	"	"	
210 2832-3	"	"		210 2867-9	"	"	
210 2833-1	"	"		210 2868-7	"	"	
210 2834-9	"	"		210 2869-5	"	"	
210 2835-6	"	"		210 2870-3	"	"	
210 2836-4	"	"		210 2871-1	"	"	

His

G5 type 4-vogner med internasjonal litrering og nummerering.

Vogn nr.	Fabr.	Byggeår	Merknad	Vogn nr.	Fabr.	Byggeår	Merknad
21 76 210 2902-4	Edf	66		21 76 210 2937-0	Edf	67	
210 2903-2	"	"		210 2938-8	"	"	
210 2904-0	"	67		210 2939-6	"	"	
210 2905-7	"	"		210 2940-6	"	"	
210 2906-5	"	"		210 2941-2	"	"	
210 2907-3	"	"		210 2942-0	"	"	
210 2908-1	"	"		210 2943-8	"	"	
210 2909-9	"	"		210 2944-6	"	"	
210 2910-7	"	"		210 2945-3	"	"	
210 2911-5	"	"		210 2946-1	"	"	
210 2912-3	"	"		210 2947-9	"	"	
210 2913-1	"	"		210 2948-7	"	"	
210 2914-9	"	"		210 2949-5	"	"	
210 2915-6	"	"		210 2950-3	"	"	
210 2916-4	"	"					
210 2917-2	"	"					
210 2918-0	"	"					
210 2919-8	"	"					
210 2920-6	"	"					
210 2921-4	"	"					
210 2922-2	"	"					
210 2923-0	"	"					
210 2924-8	"	"					
210 2925-5	"	"					
210 2926-3	"	"					
210 2927-1	"	"					
210 2928-9	"	"					
210 2929-1	"	"					
210 2930-5	"	"					
210 2931-3	"	"					
210 2932-1	"	"					
210 2933-9	"	"					
210 2934-7	"	"					
210 2935-4	"	"					
210 2936-2	"	"					

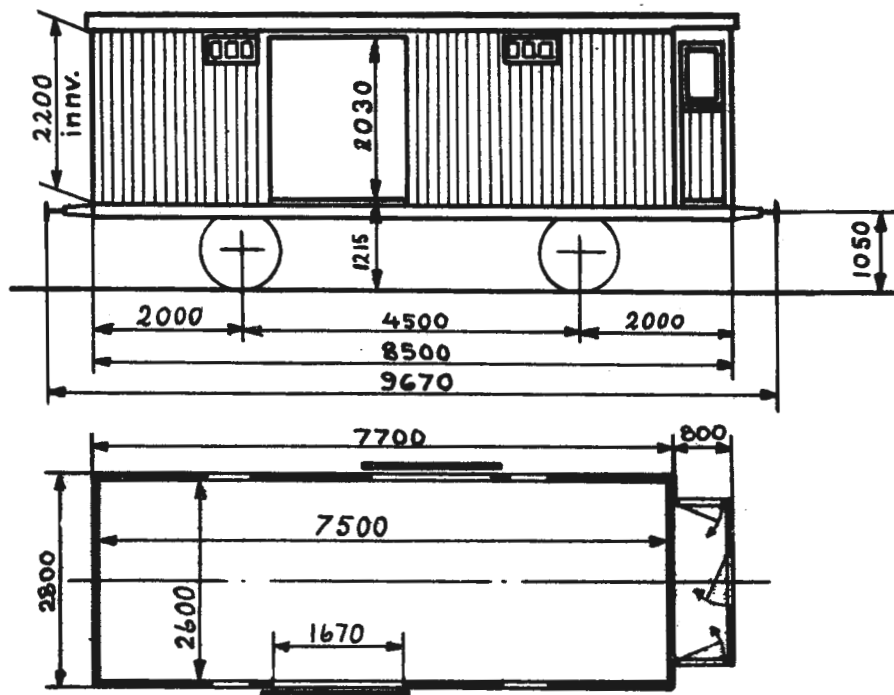

Omtrentlig vognvekt	9,5 t
" last	13,5 t
Gulvflate	19,6 m ²
Rominhold	41,1 m ³
Hovedtegning	648

LUKKET GODSVOGN

Vogn nr.	Fabr.	Byggeår	Merknad	Vogn nr.	Fabr.	Byggeår	Merknad
13012	Str	02					
13013	"	"					
13014	"	"					
13015	"	"					
13016	"	"					
13017	"	"					
13018	"	"					
13019	"	"					
13020	"	"					

Gf02

TYPE 1

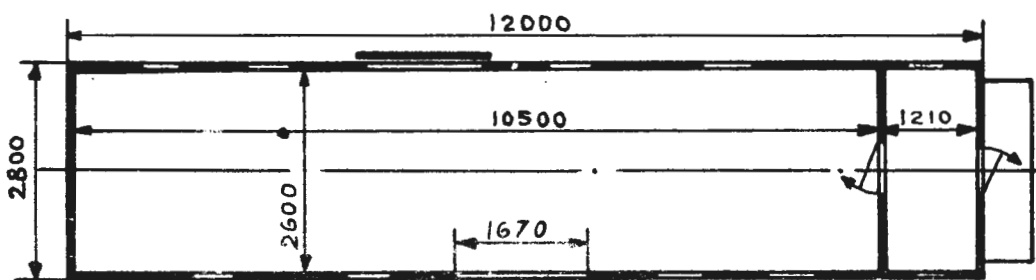
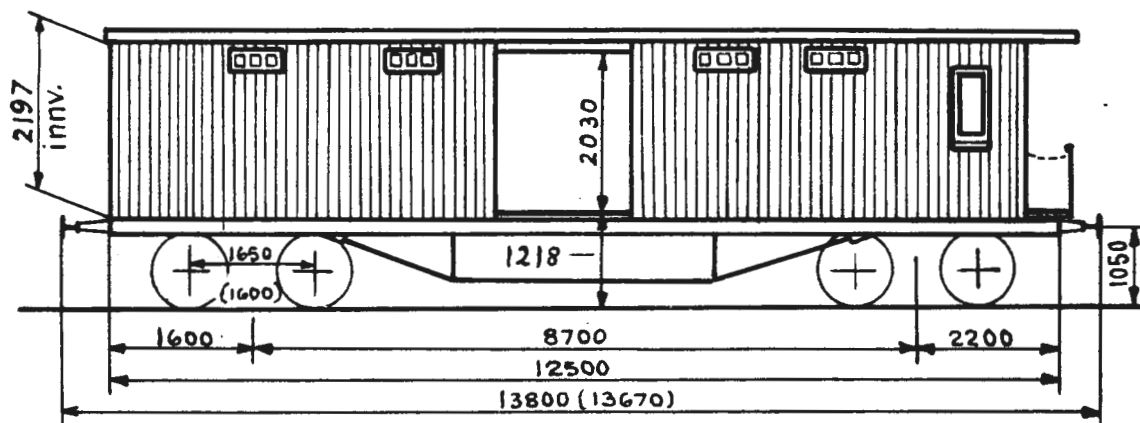

Grunnriss 1

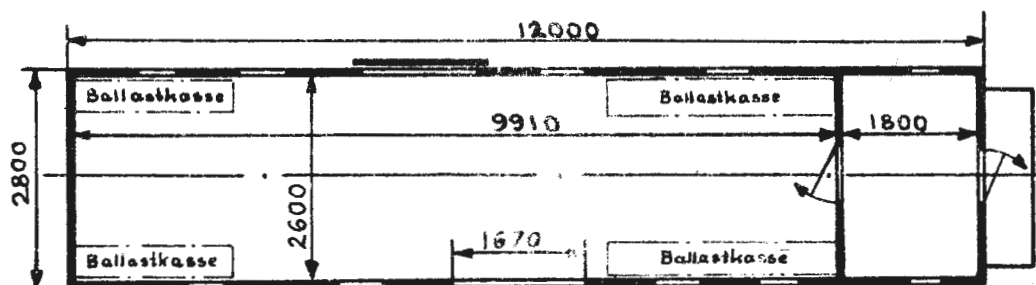

Grunnriss 2

Omtrentlig vognvekt 15,5-16,0 t
 " last + ballast 19,0 t
 Gulvflate 27,3 m² 1) 25,8 m² 2)
 Rominnhold 57,8 m³ 1) 56,8 m³ 2)
 Hovedtegning 770

LUKKET GODSVOGN

Vogn nr.	Fabr.	Byggeår	Merknad	Vogn nr.	Fabr.	Byggeår	Merknad
6201	Str	05	2)	12182	Str	17	2) 3)
6202	"	"	2) 3)	14100	"	16	1)
6210	"	18	2) 3)				
10194	"	17	2) 3)				
10196	"	19	1)				
12181	"	17	1)				

1) Grunnriss 1. 2) Grunnriss 2. 3) Har ballast.

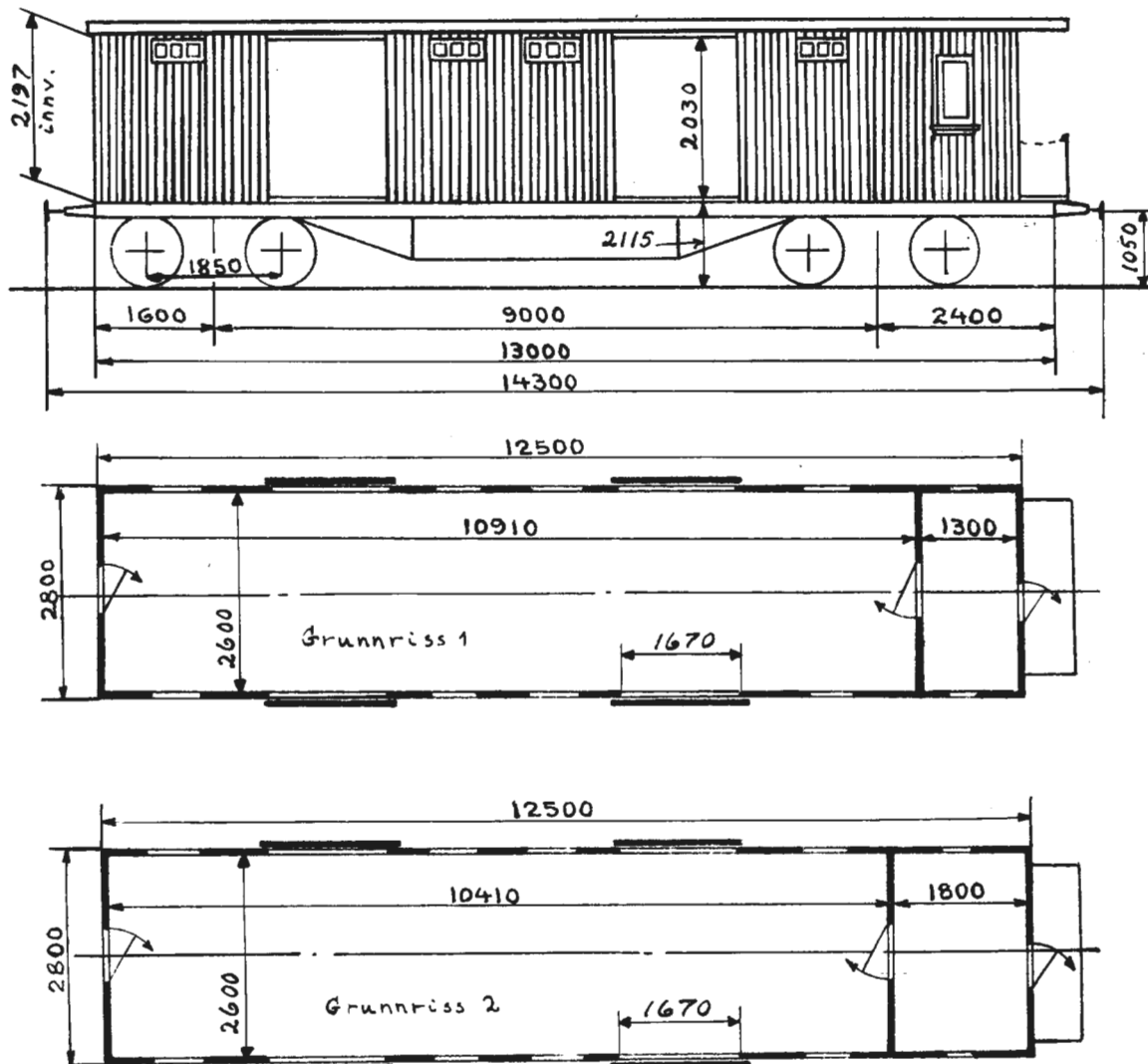

Omtrentlig vognvekt 16,0-17,5 t
 " last + ballast 17,0 t
 Gulvflate 28,4 m² 1) 27,1 m² 2)
 Rominnhold 60,4 m³ 1) 57,6 m³ 2)
 Hovedtegning 2633

LUKKET GODSVOGN

Vogn nr.	Fabr.	Byggeår	Merknad	Vogn nr.	Fabr.	Byggeår	Merknad
3340	Skb	23	2) 4)	5714	Skb	23	2) 4)
3341	"	"	2) 4)	14129	"	"	2) 3)
3344	"	"	2)	14133	"	"	2)
5151	"	"	2) 3)	14136	"	"	2) 4)
5707	"	"	2)				
5712	"	"	1) 3)				

1) Grunnriss 1. 2) Grunnriss 2. 3) Har ballast. 4) Benyttes som ren godsvogn. Dør mellom konduktør- og godsrom, samt endedør i godsrom er gjenpanelt.

Gfo2

TYPE 3

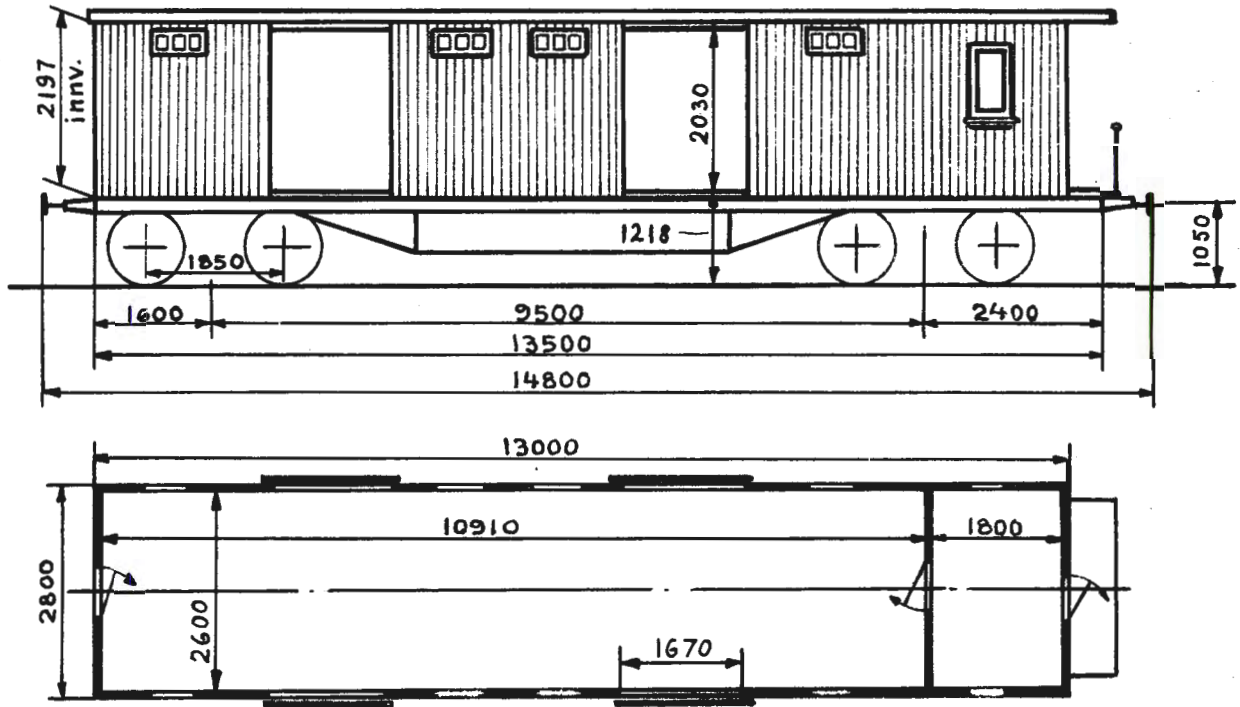

Omtrentlig vognvekt	16,5-17,5 t
" bæreevne	17,5-19,0 t
Gulvflate	27,1-28,4 m ²
Rominnhold	57,6-60,4 m ³
Hovedtegning	2898

LUKKET GODSVOGN

Vogn nr.	Fabr.	Byggeår	Merknad	Vogn nr.	Fabr.	Byggeår	Merknad
3397	Str	25					
3402	"	"	1)				
3408	Skb	29					
3409	"	"					
10233	Str	25	2)				
10240	"	"	2)				
10243	"	"	2)				
14143	"	26					
14146	"	"	2)				
15378	"	25	1)				
15406	Edf	32					

1) Har ballast. 2) Benyttes som ren godsvogn. Dør mellom konduktør- og godsrom, samt endedør i godsrom er gjenpanelt.

Gh4
TYPE 1

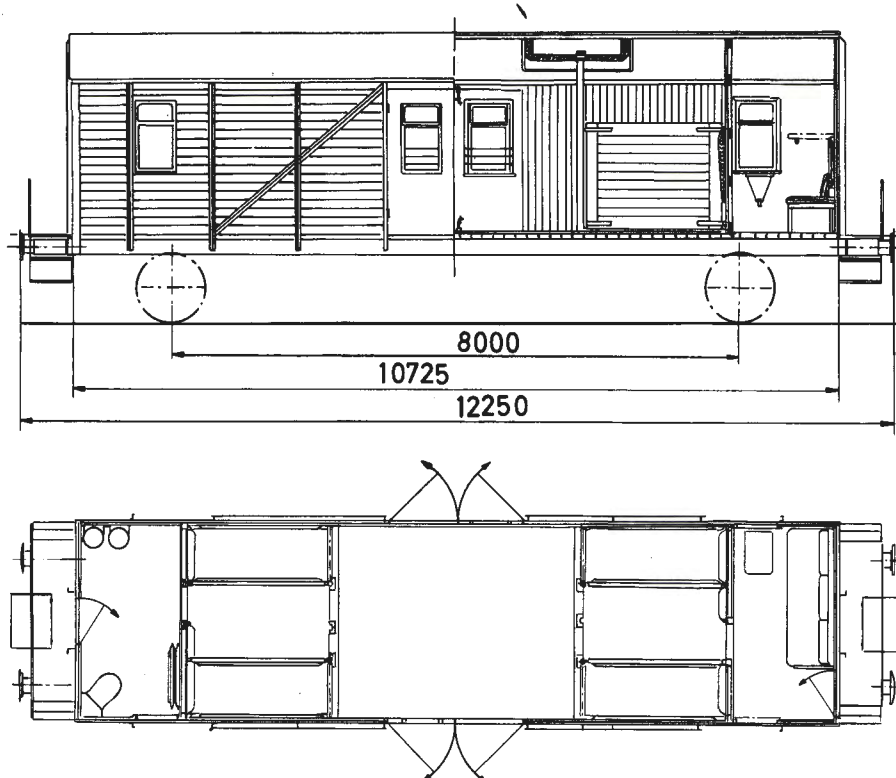

Bæreevne			
	A	B	C
	11,5t	11,5t	
S	11,5t	11,5t	

Omtrentlig vognvekt 15,5t
 Gulvflate 20,0m²
 Rominnhold 41,0m³
 Hovedtegning 8050¹⁾

LUKKET GODSVOGN (HESTETRANSPORTVOGN)

Vogn nr.	Fabr.	Byggeår	Merknad	Vogn nr.	Fabr.	Byggeår	Merknad
1250	2)	3) 4)					

1) Ombygd fra R-vogn nr. 1250, år 1959. 2) Fabrikant ukjent. 3) Oppr. byggeår 1923.
 4) Ballast.

Trykk nr. 752 1.1.68

G14

TYPE 1

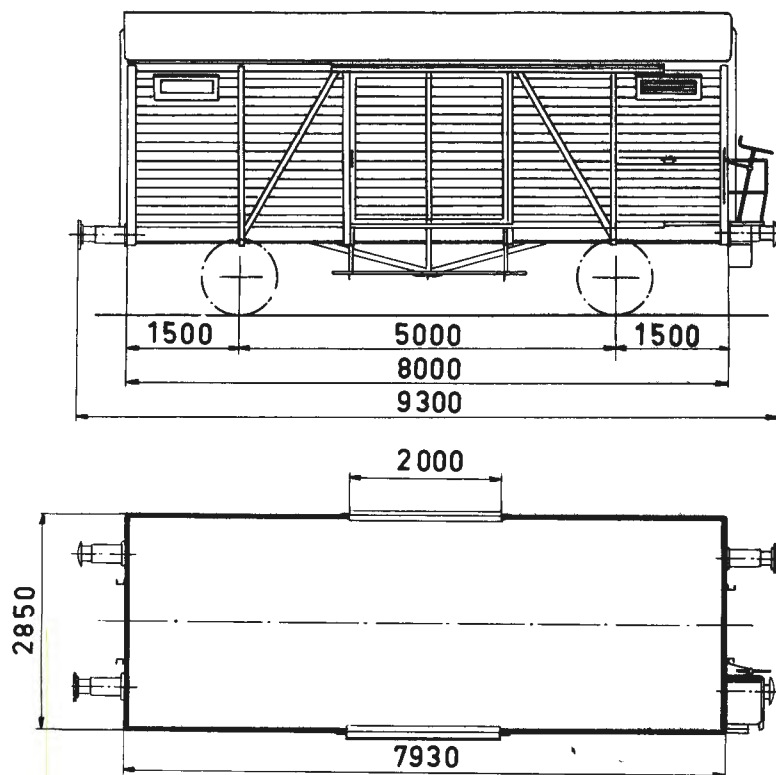

Bæreevne

A	B	C
20,0t	20,0t	

Omtrentlig vognvekt 9,0-10,0t
 Gulvflate 22,2 m²
 Rominnhold 46,0 m³
 Hovedtegning 8180¹⁾

LUKKET GODSVOGN

Vogn nr.	Fabr.	Byggeår	Merknad	Vogn nr.	Fabr.	Byggeår	Merknad
48000	Skb	52		48014	Skb	52	
48001	"	51		48015	"	51	
48002	"	"		48016	"	"	
48003	"	"		48017	"	53	
48004	"	52		48018	"	52	
48005	"	53		48019	"	53	
48006	"	52		48020	"	"	
48007	"	"		48021	"	52	
48008	"	53		48022	"	"	
48009	"	51		48023	"	"	
48010	"	53		48024	"	"	
48011	"	52		48025	"	"	
48012	"	51		48026	"	53	
48013	"	"		48027	"	52	

¹⁾ Omb. fra L4 - vogner.

Vogn nr.	Fabr.	Byggeår	Merknad	Vogn nr.	Fabr.	Byggeår	Merknad
48028	Skb	52					
48029	"	"					
48030	"	"					
48031	"	"					
48032	"	"					
48033	"	"					
48034	"	"					
48035	"	53					
48036	"	52					
48037	"	"					
48038	"	"					
48039	"	"					
48040	"	51					
48041	"	"					
48042	"	52					
48043	"	53					
48044	"	52					
48045	"	50					
48046	"	53					
48047	"	51					
48048	"	53					
48049	"	51					

Glm

G14 type 1-vogner med internasjonal litrering og nummerering.

Vogn nr.	Fabr.	Byggeår	Merknad	Vogn nr.	Fabr.	Byggeår	Merknad
21 76 103 0000-6	Skb	52					
103 0002-2	"	51					
103 0005-5	"	53					
103 0007-1	"	52					
103 0008-9	"	53					
103 0009-7	"	51					
103 0010-5	"	53					
103 0011-3	"	52					
103 0014-7	"	"					
103 0015-4	"	51					
103 0018-8	"	52					
103 0019-6	"	53					
103 0021-2	"	52					
103 0029-5	"	"					

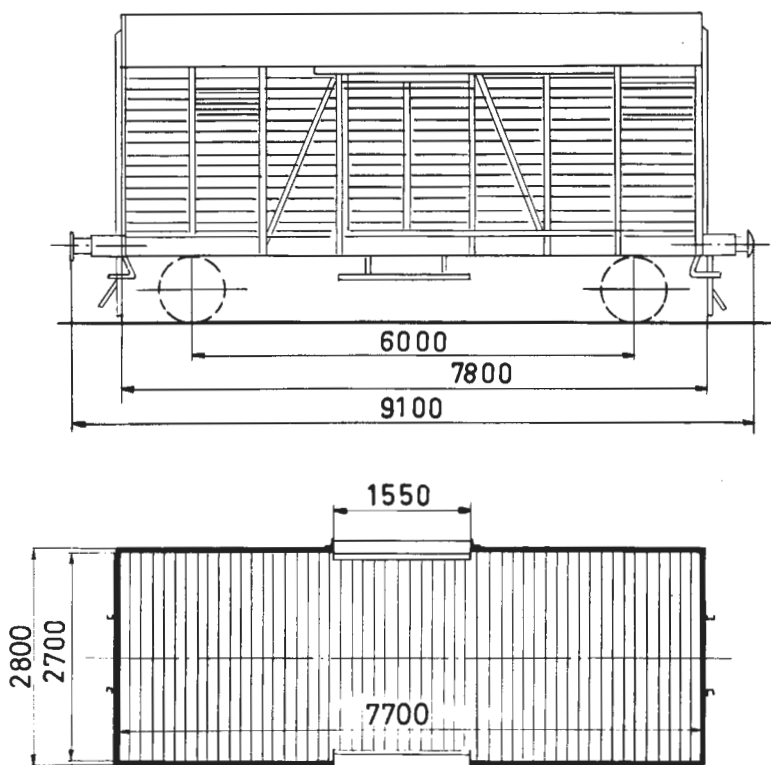

Bæreevne

	A	B	C
	16,0t	16,0t	
S	12,0t		

Omtrentlig vognvekt 10,5-12,5t

Gulvflate 21,2-21,3 m²

Rominhold 44,5-45,7 m³

Hovedtegning ukjent

LUKKET GODSVOGN

Vogn nr.	Fabr.	Byggeår	Merknad	Vogn nr.	Fabr.	Byggeår	Merknad
33100	WM	42		33114	JR	41	4)
33101	Sim	39		33115	WM	40	
33102	WD	41		33116	JR	"	
33103	GL	"		33117	Sim	38	4)
33104	WD	"		33118	LH	39	
33105	Lut	"		33119	1) 2)		
33106	Sim	38		33120	GL	42	
33107	GL	41	ul. 100	33121	"	43	
33108	Sim	42		33122	WAg	41	3) 4) 5000
33109	WM	40		33123	WD	38	5000
33110	1)	39		33124	WAg	43	
33111	1)	2)		33125	GL	42	
33112	LH	35		33126	WD	39	3)
33113	1)	2)		33127	"	41	5000

1) Vognfabrikant ukjent. 2) Byggeår ukjent. 3) Elektrisk lys for tilkobling til nabovogn. 4) Har ballast.

Vogn nr.	Fabr.	Byggeår	Merknad	Vogn nr.	Fabr.	Byggeår	Merknad
33128	GL	43					
33129	"	42					
33130	BWM	" 3)					
33131	WM	43					
33132	Sim	42					
33133	GL	" 4)					
33134	GWA	" 4)					
33135	GL	43					
33136	Sim	"					
33137	WD	41					
33138	WM	42					
33139	NW	14					
33140	JR	41					
33141	WM	2) 4)					
33142	"	41 4)					
33143	WAg	42 4)					
33144	GL	" 4)					
33145	WM	40 4)					
33146	BWM	" 4)	5007				
33147	WD	" 4)					
33148	Sim	43 4)					
33149	GL	42 4)					
33151	WD	40 4)					
33152	Sim	43 4)					
33153	GL	41 4)	5014				
33154	BWM	42 4)					
33155	Sim	" 4)					
33156	NW	"	5016				
33157	GWA	41					
33158	WAg	42 4)	44				
33159	GL	"	48				
33160	WAR	41 4)	48				
34900	BWM	42 4)					
34901	"	"					

2) Byggeår ukjent. 3) Elektrisk lys for tilkobling til nabovogn.
4) Har ballast.

Gp4 type 1-vogner med internasjonal litrering og nummerering.

Vogn nr.	Fabr.	Byggeår	Merknad	Vogn nr.	Fabr.	Byggeår	Merknad
21 76 139 5000-5	WM	42					
139 5008-8	"	40					
139 5009-6	1)	39					
139 5011-2	LH	35					
139 5012-0	1)	2)					
139 5013-8	JR	41	4)				
139 5016-1	Sim	38	4)				
139 5017-9	LH	39	4)				
139 5019-5	GL	42	4)				
139 5020-3	"	43	4)				
139 5024-5	"	"					
139 5025-2	"	42	4)				
139 5027-8	WM	43					
139 5028-6	Sim	42					
139 5029-4	GL	"	4)				
139 5030-2	GWA	"	4)				
139 5031-0	Sim	43	4)				
139 5032-8	WM	42					
139 5035-1	"	2)	3)4)				
139 5037-7	WAg	42	4)				
139 5038-5	GL	"	3)4)				
139 5043-5	Sim	43	4)				
139 5044-3	GL	41	4)				
139 5046-8	GWA	"					
139 5047-6	WAg	42	4)				
139 5048-4	GL	"	3)4)				
139 5050-0	BWM	"	3)4)				
139 5051-8	"	"					
139 5052-6	WD	38					
139 5053-4	BWM	42	3)4)				
139 5054-2	"	40	3)4)				
139 5055-9	WD	41	3)				
139 5056-7	NW	42	3)4)				

1) Vognfabrikant ukjent. 2) Byggeår ukjent., 3) Elektrisk lys for tilkopling til nabovogn. 4) Ballast.

Gr 5
TYPE 1

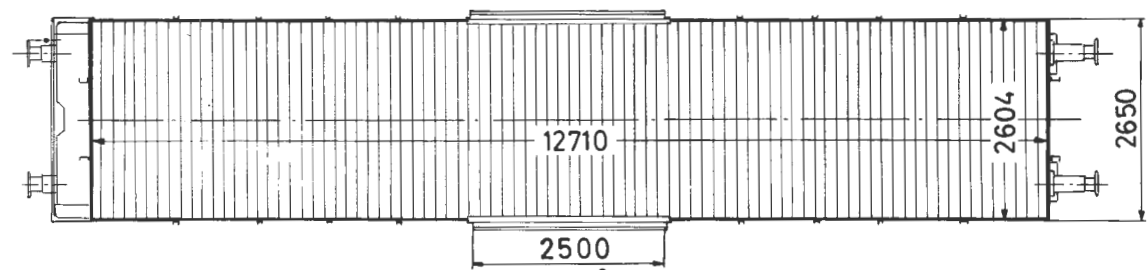
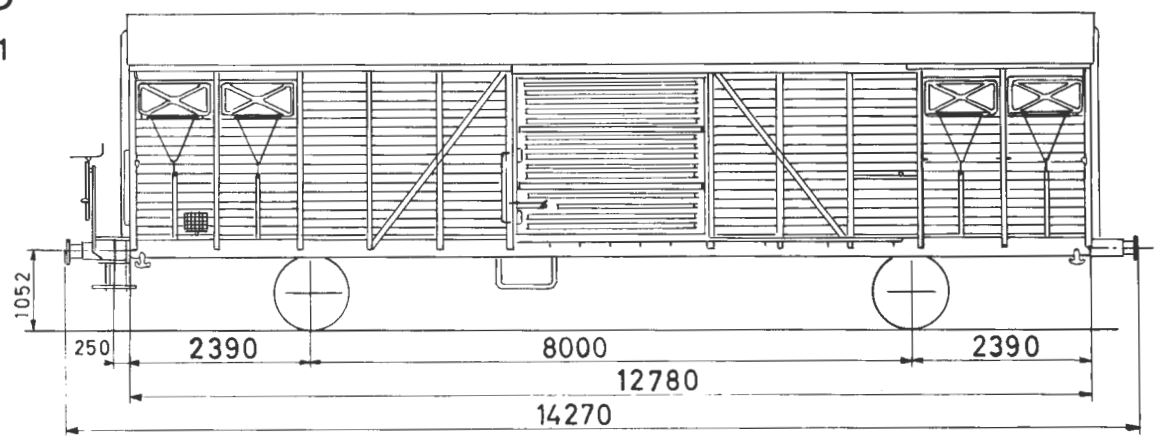

Fri höjde i döråpn: 2150 mm

Bæreevne

	A	B	C
	18,0t	22,0t	26,0t
S	18,0t	22,0t	

Omtrentlig vognvekt	14,0 t
Gulvflate	33,0 m ²
Rominnhold	83,0 m ³
Hovedtegning	13500, 13679 ¹⁾

LUKKET GODSVOGN

Vogn nr.	Fabr.	Byggeår	Merknad	Vogn nr.	Fabr.	Byggeår	Merknad
46000	Hök	63		46014	Hök	63	
46001	"	"		46015	"	"	
46002	"	"		46016	"	"	
46003	"	"		46017	"	"	
46004	"	"		46018	"	"	
46005	"	"		46019	"	"	
46006	"	"		46020	"	"	
46007	"	"		46021	"	"	
46008	"	"		46022	"	"	
46009	"	"		46023	"	"	
46010	"	"		46024	"	"	
46011	"	"		46025	"	"	
46012	"	"		46026	"	"	
46013	"	"		46027	"	"	

1) For vg.nr. 46168, 46169 og 46280-46299.

Vogn nr.	Fabr.	Byggeår	Merknad	Vogn nr.	Fabr.	Byggeår	Merknad
46028	Hök	63		46063	Hök	63	
46029	"	"		46064	"	64	
46030	"	"		46065	"	"	
46031	"	"		46066	"	"	
46032	"	"		46067	"	"	
46033	"	"		46068	"	"	
46034	"	"		46069	"	"	1)
46035	"	"		46070	"	"	
46036	"	"		46071	"	"	
46037	"	"		46072	"	"	
46038	"	"		46073	"	"	
46039	"	"		46074	"	"	
46040	"	"		46075	"	"	
46041	"	"		46076	"	"	
46042	"	"		46077	"	"	
46043	"	"		46078	"	"	
46044	"	"		46079	"	"	
46045	"	"		46080	"	"	
46046	"	"		46081	"	"	
46047	"	"		46082	"	"	
46048	"	"		46083	"	"	
46049	"	"		46084	"	"	
46050	"	"		46085	"	"	
46051	"	"		46086	"	"	
46052	"	"		46087	"	"	
46053	"	"		46088	"	"	
46054	"	"		46089	"	"	
46055	"	"		46090	"	"	
46056	"	"		46091	"	"	
46057	"	"		46092	"	"	
46058	"	"		46093	"	"	
46059	"	"		46094	"	"	
46060	"	"		46095	"	"	
46061	"	"		46096	"	"	
46062	"	"		46097	"	"	

1) Elektr. lys for tilkopling til nabovogn.

Vogn nr.	Fabr.	Byggear	Merknad	Vogn nr.	Fabr.	Byggear	Merknad
46098	Hök	64		46133	Hök	65	
46099	"	"		46134	"	"	
46100	"	"		46135	"	"	
46101	"	"		46136	"	"	
46102	"	"		46137	"	"	
46103	"	"		46138	"	"	
46104	"	"		46139	"	"	
46105	"	"		46140	"	"	
46106	"	"		46141	"	"	
46107	"	"		46142	"	"	
46108	"	"		46143	"	"	
46109	"	"		46144	"	"	
46110	"	"		46145	"	"	
46111	"	"		46146	"	"	
46112	"	"		46147	"	"	
46113	"	"		46148	"	"	
46114	"	"		46149	"	"	
46115	"	"		46150	"	"	
46116	"	"		46151	"	"	
46117	"	"		46152	"	"	
46118	"	"		46153	"	"	
46119	"	65		46154	"	"	
46120	"	"		46155	"	"	
46121	"	"		46156	"	"	
46122	"	"		46157	"	"	
46123	"	"		46158	"	"	
46124	"	"		46159	"	"	
46125	"	"		46160	"	"	
46126	"	"		46161	"	"	
46127	"	"		46162	"	"	
46128	"	"		46163	"	"	
46129	"	"		46164	"	"	
46130	"	"		46165	"	"	
46131	"	"		46166	"	"	
46132	"	"		46167	"	"	

Vogn nr.	Fabr.	Byggeår	Merknad	Vogn nr.	Fabr.	Byggeår	Merknad
46168	Hök	65	2)	46203	Hök/ Edf	63	
46169	"	"	2)	46204	"	"	
46170	Hök/ Edf	64		46205	"	"	
46171	"	"		46206	"	"	
46172	"	"		46207	"	"	
46173	"	"		46208	"	"	
46174	"	"		46209	"	"	
46175	"	65		46210	"	"	
46176	"	"		46211	"	"	
46177	"	"		46212	"	"	
46178	"	"		46213	"	"	
46179	"	"		46214	"	"	
46180	"	63		46215	"	"	
46181	"	"		46216	"	"	
46182	"	"		46217	"	"	
46183	"	"		46218	"	"	
46184	"	"		46219	"	"	
46185	"	"		46220	"	"	
46186	"	"		46221	"	"	2)
46187	"	"		46222	"	"	2)
46188	"	"		46223	"	"	
46189	"	"		46224	"	"	
46190	"	"		46225	"	"	
46191	"	"		46226	"	"	
46192	"	"		46227	"	"	
46193	"	"		46228	"	"	
46194	"	"		46229	"	"	
46195	"	"		46230	"	"	
46196	"	"		46231	"	"	
46197	"	"		46232	"	"	
46198	"	"		46233	"	"	
46199	"	"		46234	"	"	
46200	"	"		46235	"	64	
46201	"	"		46236	"	"	
46202	"	"		46237	"	"	

2) Isolert. V.v. 16,0 t (nr. 46221 og 46222 v.v. 15,0 t). Bæreevne
A: 17,0 t, B: 21,0 t, C: 25,0 t. Som S-vogn A: 17,0 t, BC: 21,0 t.

Vogn nr.	Fabr.	Byggear	Merknad	Vogn nr.	Fabr.	Byggear	Merknad
46238	Hbk/Edf	64		46273	Hbk/Edf	64	
46239	"	"		46274	"	"	
46240	"	"		46275	"	"	
46241	"	"		46276	"	"	
46242	"	"		46277	"	"	
46243	"	"		46278	"	"	
46244	"	"		46279	"	"	
46245	"	"		46280	"	65	3)
46246	"	"		46281	"	"	3)
46247	"	"		46282	"	"	3)
46248	"	"		46283	"	"	3)
46249	"	"		46284	"	"	3)
46250	"	"		46285	"	"	3)
46251	"	"		46286	"	"	3)
46252	"	"		46287	"	"	3)
46253	"	"		46288	"	"	3)
46254	"	"		46289	"	"	3)
46255	"	"		46290	"	"	3)
46256	"	"		46291	"	"	3)
46257	"	"		46292	"	"	3)
46258	"	"		46293	"	"	3)
46259	"	"		46294	"	"	3)
46260	"	"		46295	"	"	3)
46261	"	"		46296	"	"	3)
46262	"	"		46297	"	"	3)
46263	"	"		46298	"	"	3)
46264	"	"		46299	"	"	3)
46265	"	"					
46266	"	"					
46267	"	"					
46268	"	"					
46269	"	"					
46270	"	"					
46271	"	"					
46272	"	"					

3) Isolert. Innredet for banantransport. V.v.: 16,0 t. Bæreevne
A: 16,0 t, B: 20,0 t, C: 24,0 t. Som S-vogn A: 16,0 t, BC: 20,0 t.

Gr5 type 1-vogner med internasjonal litrering og nummerering.

Vogn nr.	Fabr.	Byggeår	Merknad	Vogn nr.	Fabr.	Byggeår	Merknad
21 76 150 0003-1	Hök	63		21 76 150 0060-1	Hök	63	
150 0008-0	"	"		150 0061-9	"	"	
150 0010-6	"	"		150 0063-5	"	"	
150 0012-2	"	"		150 0065-0	"	64	
150 0013-0	"	"		150 0069-2	"	"	1)
150 0016-3	"	"		150 0079-1	"	"	
150 0023-9	"	"		150 0094-0	"	"	
150 0024-7	"	"		150 0100-5	"	"	
150 0025-4	"	"		150 0102-1	"	"	
150 0027-0	"	"		150 0108-8	"	"	
150 0028-8	"	"		150 0170-8	Hök/ Edf	63	
150 0029-6	"	"		150 0178-1	"	"	
150 0030-4	"	"		150 0179-9	"	"	
150 0031-2	"	"		150 0182-3	"	"	
150 0033-8	"	"		150 0185-6	"	"	
150 0036-1	"	"		150 0187-2	"	"	
150 0037-9	"	"		150 0188-0	"	"	
150 0038-7	"	"		150 0190-6	"	"	
150 0039-5	"	"		150 0191-4	"	"	
150 0041-1	"	"		150 0192-2	"	"	
150 0042-9	"	"		150 0193-0	"	"	
150 0043-7	"	"		150 0194-8	"	"	
150 0045-2	"	"		150 0195-5	"	"	
150 0046-0	"	"		150 0197-1	"	"	
150 0047-8	"	"		150 0200-3	"	"	
150 0048-6	"	"		150 0201-1	"	"	
150 0049-4	"	"		150 0202-9	"	"	
150 0050-2	"	"		150 0203-7	"	"	
150 0051-0	"	"		150 0204-5	"	"	
150 0052-8	"	"		150 0205-2	"	"	
150 0054-4	"	"		150 0206-0	"	"	
150 0055-1	"	"		150 0207-8	"	"	
150 0056-9	"	"		150 0208-6	"	"	
150 0058-5	"	"		150 0210-2	"	"	
150 0059-3	"	"		150 0213-6	"	"	

1) Elektr. lys for tilkopling til nabovogn.

Gbs

Gr5 type 1-vogner med internasjonal litrering og nummerering.

Vogn nr.	Fabr.	Byggeår	Merknad	Vogn nr.	Fabr.	Byggeår	Merknad
21 76 150 0215-1	Hök/ Edf	63					
150 0216-9	"	"					
150 0218-5	"	"					
150 0223-5	"	"					
150 0225-0	"	64					
150 0226-8	"	"					

Gr5 type 1-vogner med internasjonal litrering og nummerering.

Vogn nr.	Fabr.	Byggear	Merknad	Vogn nr.	Fabr.	Byggear	Merknad
21 76 210 9022-4	Hök/ Edr	63	1)				
210 9023-2	"	"	1)				

1) Isolert. V.v. 15,0 t. Bæreevne A: 17,0 t, B: 21,0 t, C: 25,0 t.
Som S-vogn A: 17,0 t, BC: 21,0 t.

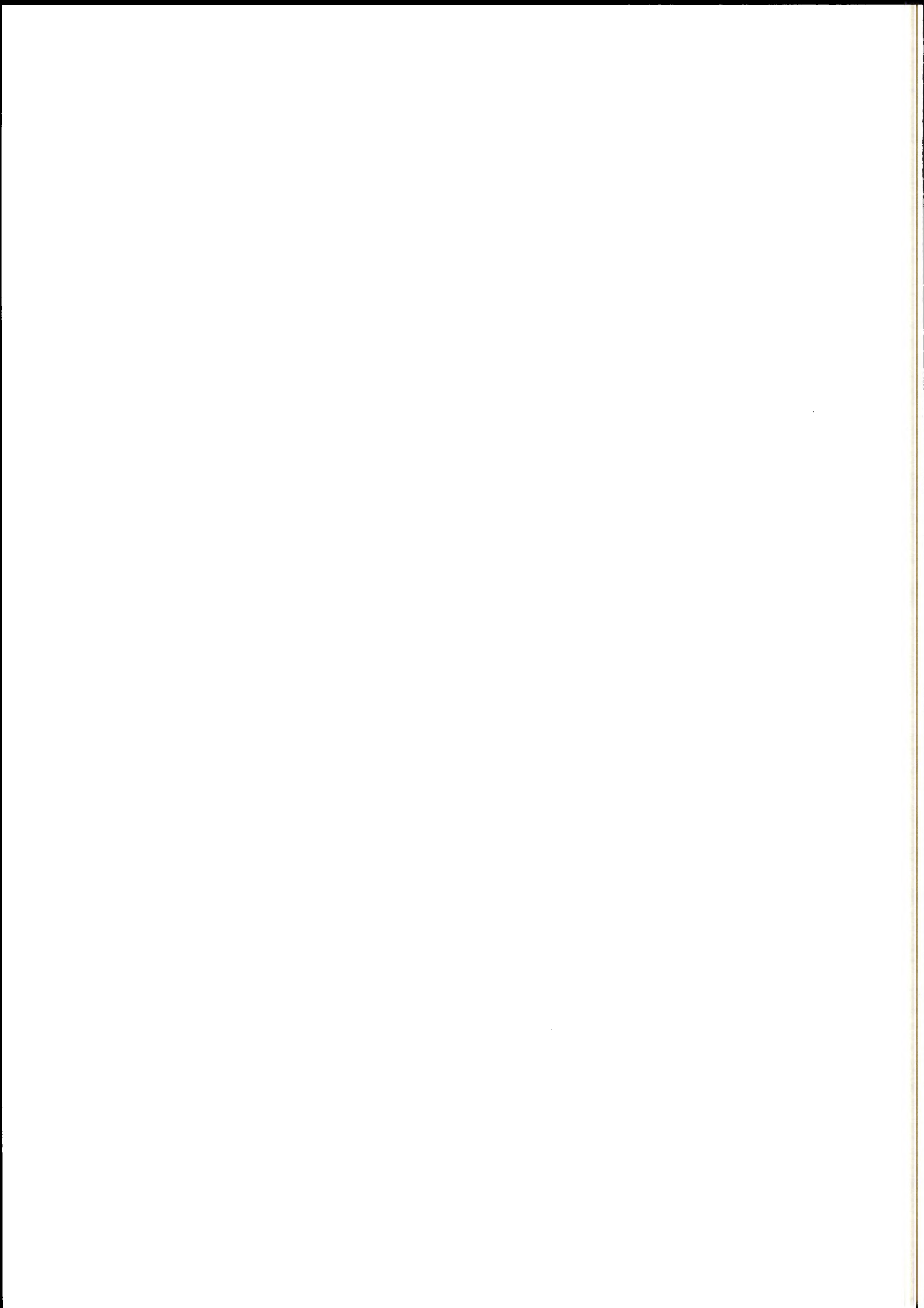

H
TYPE 1

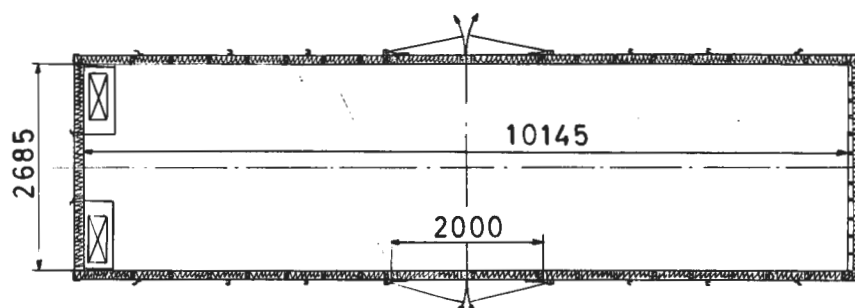
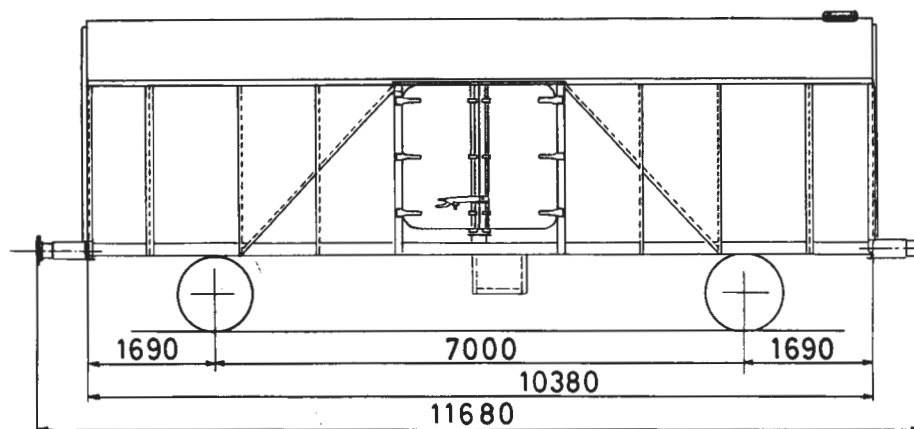

Bæreevne

	A	B	C
	16,5t	16,5t	
S	10,0t		

Omtrentlig vognvekt 13,5 t
 Gulvflate 26,1m²
 Rominnhold 58,0m³
 Hovedtegning 11460

KJÖLEVOGN

Vogn nr.	Fabr.	Byggeår	Merknad	Vogn nr.	Fabr.	Byggeår	Merknad
70500	1)	44					

1) Omb.i Oslo i 1962.

H3
TYPE 1

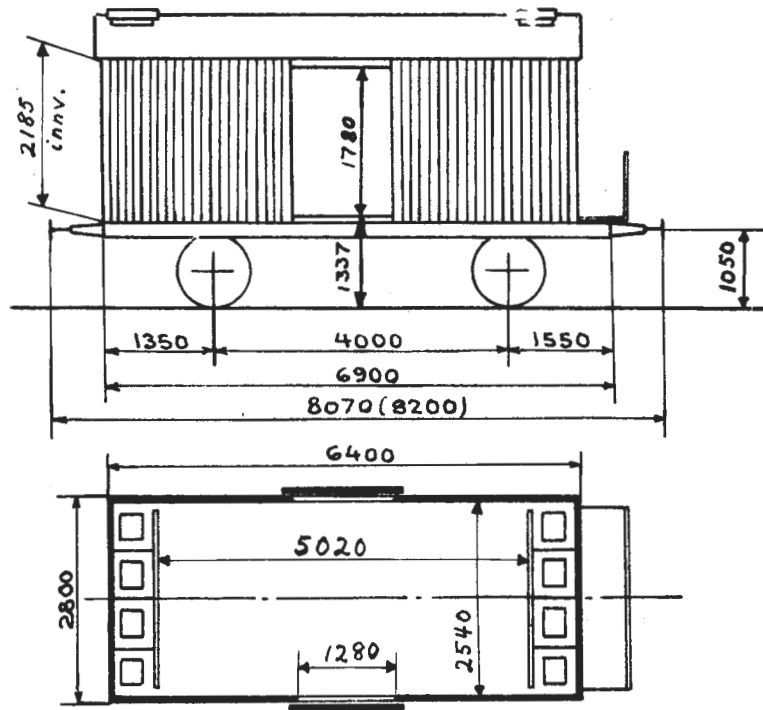

Omtrentlig vognvekt 10,5-14,0 t 1)
 " bæreevne 8,0-13,0 t 2)
 Gulvflate 12,5-15,5 m²
 Rominnhold 23,0-33,0 m³
 Hovedtegning 1504 + skisse nr. 233
 eller 1218 + skisse nr. 233

KJÖLEVOGN

Vogn nr.	Fabr.	Byggeår	Merknad	Vogn nr.	Fabr.	Byggeår	Merknad	
13100	Str	14	H-tegn. 1504 + skisse nr. 233	13116	Str	11	H-tegn. 1504 + skisse nr. 233	
13101	"	"		13117	"	"		3) 4)
13102	"	"		13120	"	"		
13106	Edf	"		13121	"	"		
13107	"	"		13126	"	"		
13108	"	"		13127	"	"		
13109	"	"		13128	"	"		3)
13110	"	"		13129	"	"		
13111	"	"		13131	"	"		
13112	"	"		13132	"	"		
13113	Str	11	5)	13134	"	"	3)	
13115	"	"		13137	HJ	15	5)	
				13138	"	14	5)	

1) Med tomme isbeholdere. 2) Inklusive is. 3) Kullsyreis. 4) Ny vognkasse. 5) Har ikke isbeholdere.

Vogn nr.	Fabr.	Byggear	Merknad	Vogn nr.	Fabr.	Byggear	Merknad
13139	HJ	14					H-tegn. 1504 + skisse nr. 233
13140	"	"		13200	Str	20	5)
13141	"	15		13201	"	"	5)
13143	"	14		13202	"	"	5)
13144	"	"		13203	"	"	5)
13145	"	"		13205	"	"	5)
13146	"	"		13206	"	"	5)
			H-tegn. 1218 + skisse nr. 233	13208	"	"	5)
13147	Edf	11		13209	"	"	5)
13148	"	"		13210	"	"	5)
13150	"	"		13212	"	14	5)
13151	"	"		13213	"	"	5)
13153	"	"		13214	"	"	5)
13154	"	"		13215	"	"	5)
13155	"	"	3)	13216	"	"	5)
13156	Str	21	3) 4)	13217	"	"	5)
13157	Skb	11		13218	"	"	5)
13158	"	"	3)	13219	"	"	
13159	"	"		13221	"	"	
13160	"	"		13222	"	"	5)
13161	"	"		13223	"	"	5)
13163	"	"		13224	"	"	5)
13164	"	"		13225	"	"	5)
13165	"	"		13226	"	"	5)
13167	"	"		13228	"	"	5)
13168	"	"		13229	"	"	5)
13169	"	"		13231	"	"	5)
13170	"	"		13232	"	"	5)
13171	"	"	3)	13233	"	"	5)
13172	"	"		13234	"	"	3) 4) 6)
13177	"	"	3)	13235	"	"	5)
13178	"	"		13236	"	"	5)
13180	"	"	5)	13237	"	"	5)

3) Kullsyreis. 4) Ny vognkasse. 5) Har ikke isbeholdere. 6) Har ikke beholdere for naturis.

Vogn nr.	Fabr.	Byggeår	Merknad	Vogn nr.	Fabr.	Byggeår	Merknad
13238	Edf	14	5)	13277	HJ	15	5)
13239	"	"	5)	13278	"	"	5)
13240	"	"		13279	"	"	5)
13241	"	"	5)	13280	"	"	5)
13242	"	"	5)	13282	"	"	5)
13244	"	"	5)	13283	"	"	5)
13246	"	"	5)	13284	"	"	5)
13247	"	"		13285	"	"	
13248	"	"	5)	13286	"	"	
			H-tegn. 1218 + skisse nr. 233	13287	"	"	5)
13250	Str	11	5)	13288	Edf	14	
13251	"	"	5)	13289	Skb	21	5)
13253	"	"	5)	13290	"	"	5)
13254	"	"	5)	13291	"	"	5)
13255	"	"	5)	13292	"	"	5)
13257	Skb	"	5)	13293	"	"	5)
			H-tegn. 1504 + skisse nr. 233	13294	"	"	5)
13258	HJ	14	5)	13295	"	"	5)
13259	"	"		13296	"	"	5)
13260	"	"	5)	13297	"	"	5)
13261	"	"	5)	13298	"	"	5)
13262	"	"	5)	13299	"	"	5)
13263	"	"		13300	"	"	5)
13264	"	"	5)	13301	"	"	5)
13265	"	"	5)	13302	"	"	5)
13266	"	"	5)	13303	"	"	5)
13267	"	"		13304	Str	20	5)
13268	"	15	5)	13305	"	"	5)
13270	"	"	5)	13306	"	"	5)
13271	"	"	5)	13307	"	"	5)
13272	"	"	5)	13308	"	"	5)
13274	"	"	5)	13309	"	"	5)
13275	"	"	5)	13310	"	"	5)
13276	"	"	5)	13311	"	"	5)
				13312	"	"	5)

5) Har ikke isbeholdere.

Vogn nr.	Fabr.	Byggeår	Merknad	Vogn nr.	Fabr.	Byggeår	Merknad
13313	Str	19	5)	13351	Str	21	5)
13314	"	"	5)	13352	"	"	5)
13315	"	"	5)	13353	"	"	5)
13317	"	"	5)	13354	"	"	5)
13319	"	"	5)	✓ 13355	"	"	5)
13320	"	"	5)	13356	"	"	5)
13321	"	"	5)	13357	"	"	5)
13322	"	"	5)	13358	"	"	5)
13323	HJ	14	5)	13359	"	"	5)
13324	"	"	5)	13360	"	"	5)
13325	"	"	5)	13361	"	"	5)
13326	"	"	5)	13362	"	"	5)
13328	"	"	5)	13363	"	"	5)
13330	"	"	5)	✓ 13364	"	"	5)
13331	"	"	5)	13365	"	"	5)
13332	"	"	5)	13366	"	"	5)
13333	Edf	11	H-tegn. 1218 + skisse nr. 233 3) 6)	13367	Skb	11	H-tegn. 1218 + skisse nr. 233 5)
13334	"	"	3) 6)	13368	"	"	3) 6)
13335	Str	19	H-tegn. 1504 + skisse nr. 233 5)	✓ 13369	Str	19	H-tegn. 1504 + skisse nr. 233 5)
13336	"	"	5)	13370	"	"	5)
13337	"	"	5)	13372	"	"	5)
✓ 13338	"	"	5)				
13339	"	"	5)				H-tegn. 1218 + skisse nr. 233
13341	"	"	5)	13373	Edf	11	5)
13342	"	"	5)	13374	"	"	5)
13343	"	"	5)				
13344	"	21	5)	13375	Str	19	H-tegn. 1504 + skisse nr. 233 5)
13345	"	19	5)	13376	"	"	5)
13346	"	21	5)	13377	"	"	5)
13347	"	"	5)	13378	"	"	5)
13348	"	"	5)	13379	"	20	5)
13350	"	"	5)				

3) Kullsyreis. 5) Har ikke isbeholdere. 6) Har ikke beholdere for naturis.

Vogn nr.	Fabr.	Byggear	Merknad	Vogn nr.	Fabr.	Byggear	Merknad
13381	Str	21	5)				
13382	"	"	5)				
13383	"	"	5)				
13384	Skb	"	5) 7)				
13385	"	"	5)				
13386	"	"	5)				
13387	"	"					
13388	"	"	5)				
13389	"	"	5)				
13390	"	"	5)				
13393	"	"	5)				
13394	"	"	5)				
13395	"	"	5)				
13397	"	22	5)				
13398	"	"	5)				
13399	"	"	5)				
13401	Str	20	5)				
13402	"	"	5)				
13403	HJ	15	5)				
13404	"	"	5)				
13405	Str	21	5)				
13406	"	20	5)				

5) Har ikke isbeholdere. 7) Innredet for banantransport.

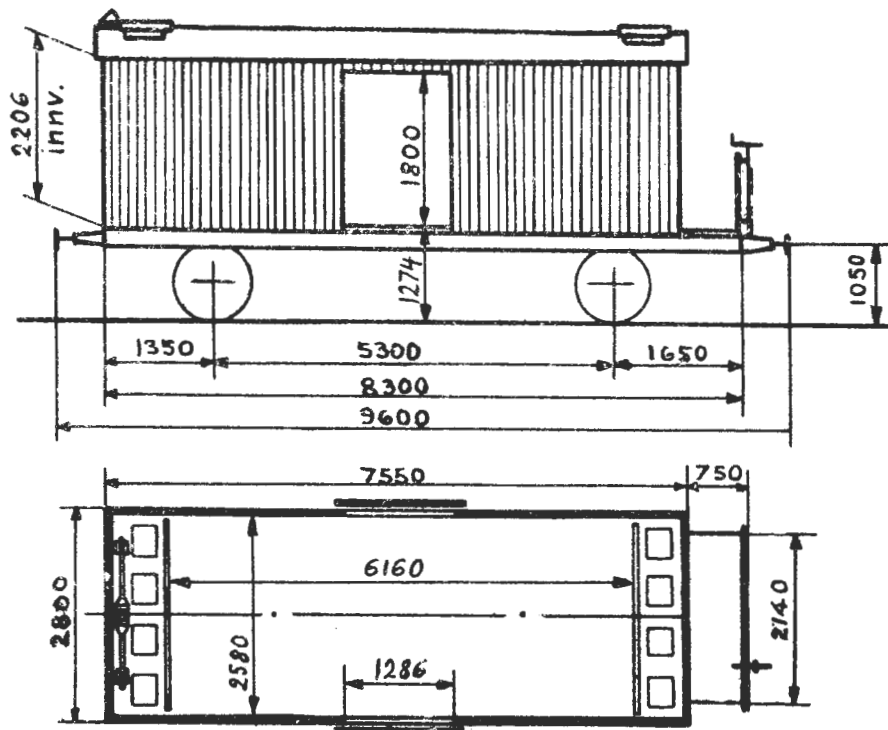

Vogner i serien 70000-70029 har som S-vogn 12,0 t bæreevne.

Omtrentlig vognvekt 14,5-17,0 t 1)
 " bæreevne 13,5-15,5 t 2)
 Gulvflate 15,8 m²
 Rominnhold 32,4 m³
 Hovedtegning 3160 + skisse
 nr. 1085

KJÖLEVOGN

Vogn nr.	Fabr.	Byggeår	Merknad	Vogn nr.	Fabr.	Byggeår	Merknad
70001	Skb	30	3)	70017	Skb	31	
70002	"	"		70019	Edf	30	
70003	"	"		70020	"	"	
70004	"	"		70021	"	"	
70005	"	"		70022	"	"	
70006	"	"		70023	"	"	
70007	"	"		70024	Skb	31	
70008	"	"					
70009	"	"					
70010	"	"					
70011	"	31					
70012	"	"					
70013	"	"	3)				
70014	"	"					
70016	"	"					

1) Med tomme isbeholdere. 2) Inklusive is. 3) Innredet som forsøksvogn for fiskeriforsøksstasjoner. Kullsyreis.

Icmors

H4 og Hf4 type 1-vogner med internasjonal litrering og nummerering.

Vogn nr.	Fabr.	Byggeår	Merknad	Vogn nr.	Fabr.	Byggeår	Merknad
11 76 806 6016-6	Skb	30	1)				
806 6017-4	"	"					
806 6018-2	"	"					
806 6019-0	"	"					
806 6020-8	"	31					
806 6021-6	"	"					
806 6022-4	"	"					
806 6024-0	Edf	30					

1) Innredet som forsøksvogn for fiskeriforsøksstasjoner. Kullsyreis.

Trykk nr. 752 1.1.68

H4 type 1-vogner med internasjonal litrering og nummerering.

Vogn nr.	Fabr.	Byggeår	Merknad	Vogn nr.	Fabr.	Byggeår	Merknad
11 76 806 6002-6	Skb	30					
806 6003-4	"	"					
806 6004-2	"	"					
806 6007-5	"	31					
806 6009-1	"	"					
806 6011-7	"	"					
806 6012-5	Edf	30					
806 6013-3	"	"					
806 6014-1	"	"					
806 6015-8	Skb	31					

H 4

TYPE 2

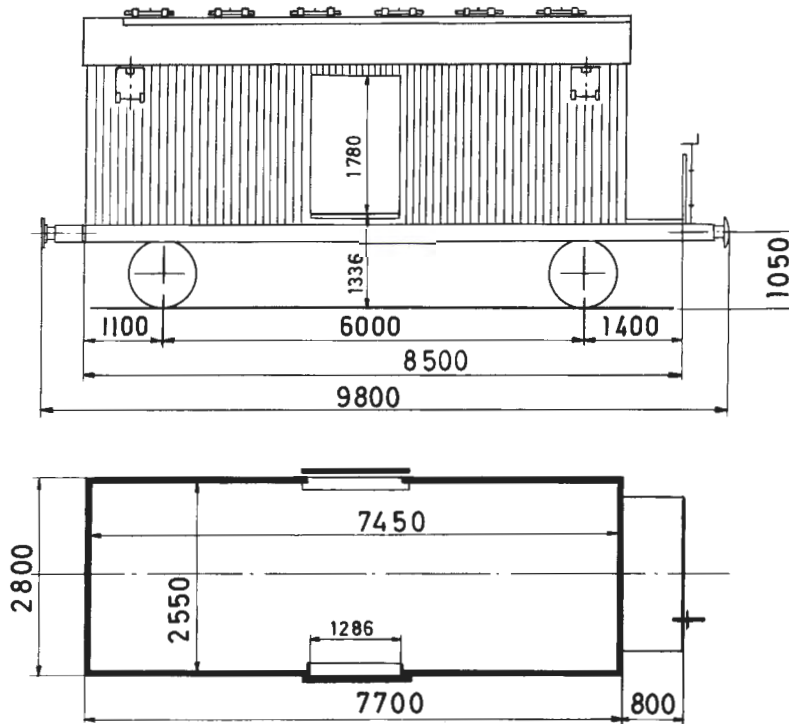

Omtrentlig vognvekt 13,0-14,0t ¹⁾
 " bæreevne 16,0-17,0t ²⁾
 Gulvflate 18,7m²
 Rominnhold 35,6m³
 Hovedtegning 5130
 + skisse nr. 1085

Alle vogner har rullelager og 12,0 t bæreevne som S-vogn.

KJÖLEVOGN

Vogn nr.	Fabr.	Byggeår	Merknad	Vogn nr.	Fabr.	Byggeår	Merknad
70025	Skb	47	3)	70049	Skb	48	3)
70026	"	"	3)	70050	Str	45	3)
70027	"	"	3)	70051	"	"	3)
70028	"	"		70053	"	"	3)
70029	"	"	3)	70054	"	"	3)
70030	"	"		70055	"	"	3)
70033	"	"	3)	70056	"	"	3)
70034	"	"	3)	70057	"	46	3)
70035	"	"	3)	70059	"	"	3)
70038	"	48		70060	"	"	3)
70039	"	"	3)	70063	"	"	3)
70042	"	"		70064	"	"	3)
70043	"	"	3)	70065	"	"	3)
70046	"	"		70066	"	"	3)

1) Med tomme isbeholdere. 2) Inklusive is. 3) Benyttes for transport av matvarer, unntatt fisk.

Vogn nr.	Fabr.	Byggear	Merknad	Vogn nr.	Fabr.	Byggear	Merknad
70067	Str	45	3)				
70068	"	46	3)				
70070	"	"	3)				
70071	"	"	3)				
70072	"	"	3)				
70073	"	"	3)				
70074	"	"	3)				

3) Benyttes for transport av matvarer, unntatt fisk.

Imors

H4 type 2-vogner med internasjonal litrering og nummerering.

Vogn nr.	Fabr.	Byggeår	Merknad	Vogn nr.	Fabr.	Byggeår	Merknad
21 76 806 6025-5	Skb	47	1)				
806 6032-1	"	"	1)				
806 6037-0	"	"					
806 6046-1	"	48					
806 6047-9	"	"	1)				
806 6049-5	"	"	1)				
806 6055-2	Str	45	1)				
806 6061-0	"	46	1)				
806 6065-1	"	"	1)				
806 6070-1	"	"	1)				
806 6073-5	"	"	1)				

1) Benyttes for transport av matvarer, unntatt fisk.

Trykk nr. 752 1.1.68

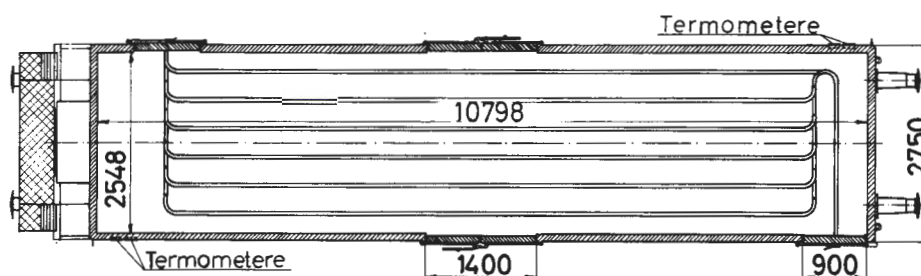
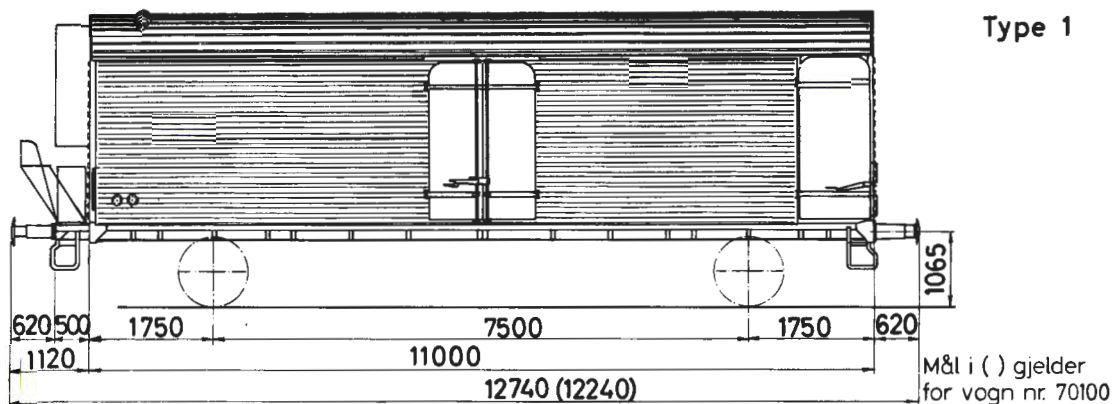

Bæreevne			
	A	B	C
	17,5 t	21,5 t	25,5 t
S	17,5 t	21,5 t	
SS	17,5 t		

Omtrentlig vognvekt	14,0 t
Gulvflate	27,5 m ²
Rominhold	57,0 m ³
Hovedtegning	14653

Kjølevogn

Vogn nr.	Fabr.	Byggeår	Merknad	Vogn nr.	Fabr.	Byggeår	Merknad
70100	Chr	63					
70101	"	64					
70102	"	"					
70103	"	"					
70104	"	"					
70105	"	"					
70106	"	"					
70107	"	"					
70108	"	"					
70109	"	"					
70110	"	"					

Hf3

TYPE 1

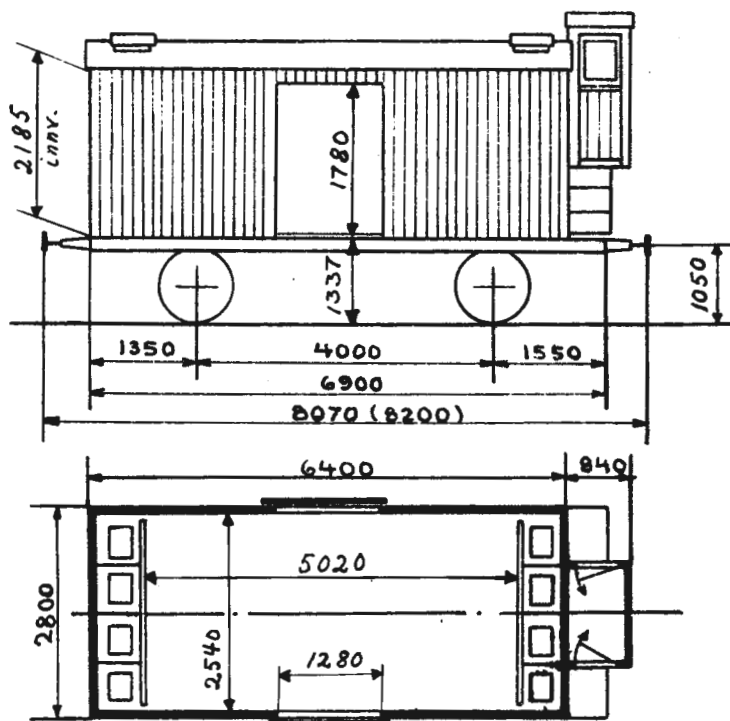

Omtrentlig vognvekt 11,0-12,0 t
 " bæreevne 12,0-13,0 t 2.
 Gulvflate 12,8 m²
 Rominnhold 26,2 m³
 Hovedtegning 1218 eller 1504

KJÖLEVOGN

Vogn nr.	Fabr.	Byggeår	Merknad	Vogn nr.	Fabr.	Byggeår	Merknad
13249	Str	11	H-tegn. 1218 4) 5)				
13256	"	"	3) 4)				
13327	HJ	14	H-tegn. 1504 3) 6) 7)				
13346	Str	21	5)				
13392	Skb	"	3)				
13400	"	22	3)				

1) Med tomme isbeholdere. 2) Inklusive is. 3) Kullsyreis. 4) Gulvflate 15,0 m², rominnhold 30,0 m³. 5) Har ikke isbeholdere. 6) Ny vognkasse. 7) Har ikke beholdere for naturis.

Trykk nr. 752 1.1.68

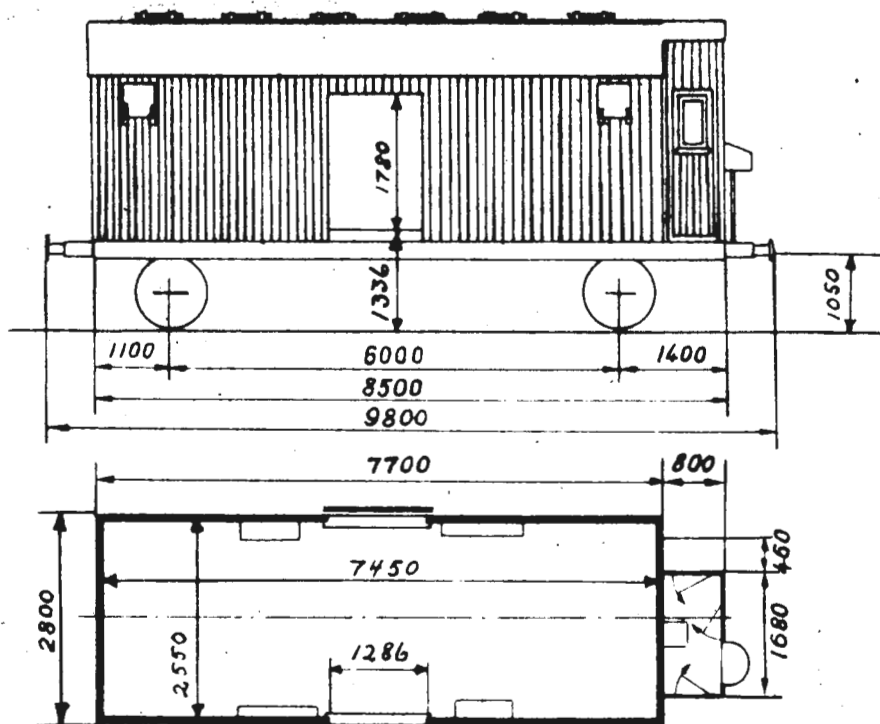

Alle vg. har rullelager og
12,0 t bæreevne som S-vogn.

Omtrentlig vognvekt	13,5-14,0 t	1)
" bæreevne	16,0-16,5 t	2)
Gulvflate	18,7	m ²
Rominnhold	35,6	m ³
Hovedtegning	5130	

KJÖLEVOGN

Vogn nr.	Fabr.	Byggeår	Merknad	Vogn nr.	Fabr.	Byggeår	Merknad
70030	Skb	47					
70031	"	"	3)				
70032	"	"	3)				
70036	"	"	3)				
70040	"	48	3)				
70041	"	"					
70044	"	"	3)				
70045	"	"	3)				
70047	"	"	3)				
70048	"	"					
70058	Str	46	3)				
70059	"	"	3)				
70062	"	"	3)				
70069	"	"	3)				

1) Med tomme isbeholdere. 2) Inklusive is. 3) Benyttes for transport av matvarer, unntatt fisk.

Hv3

TYPE 1

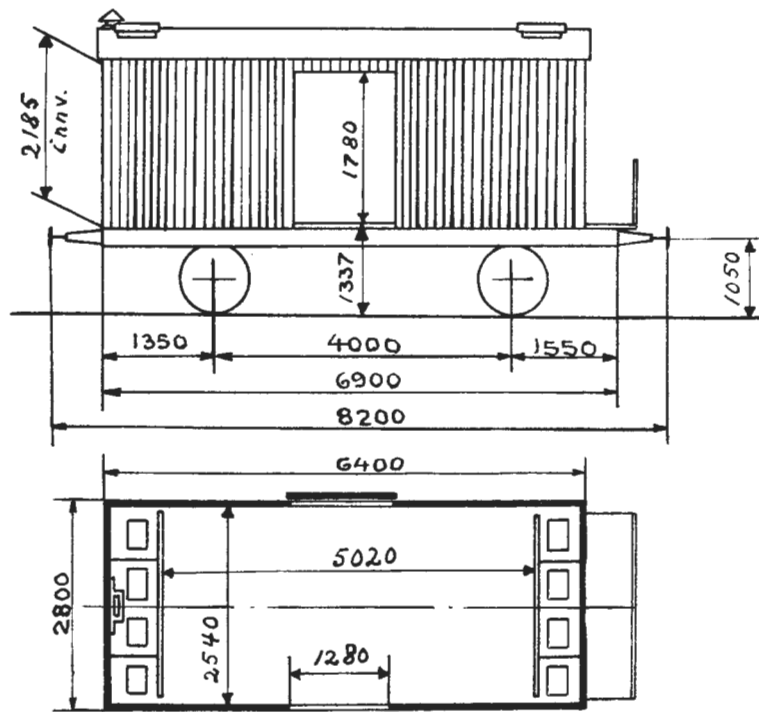

Omtrentlig vognvekt 13,0-14,0 t 1)
 " bæreevne 10,0-11,0 t 2)
 Gulvflate 12,8-13,0 m²
 Rominnhold 26,2-26,6 m³
 Hovedtegning 1504 + skisse nr. 233

KJÖLE- OG VARMEVOGN

Vogn nr.	Fabr.	Byggeår	Merknad	Vogn nr.	Fabr.	Byggeår	Merknad
13281	HJ	15					
13580	Str	21					

1) Med tomme isbeholdere. 2) Inklusive is.

Hv4

TYPE 1

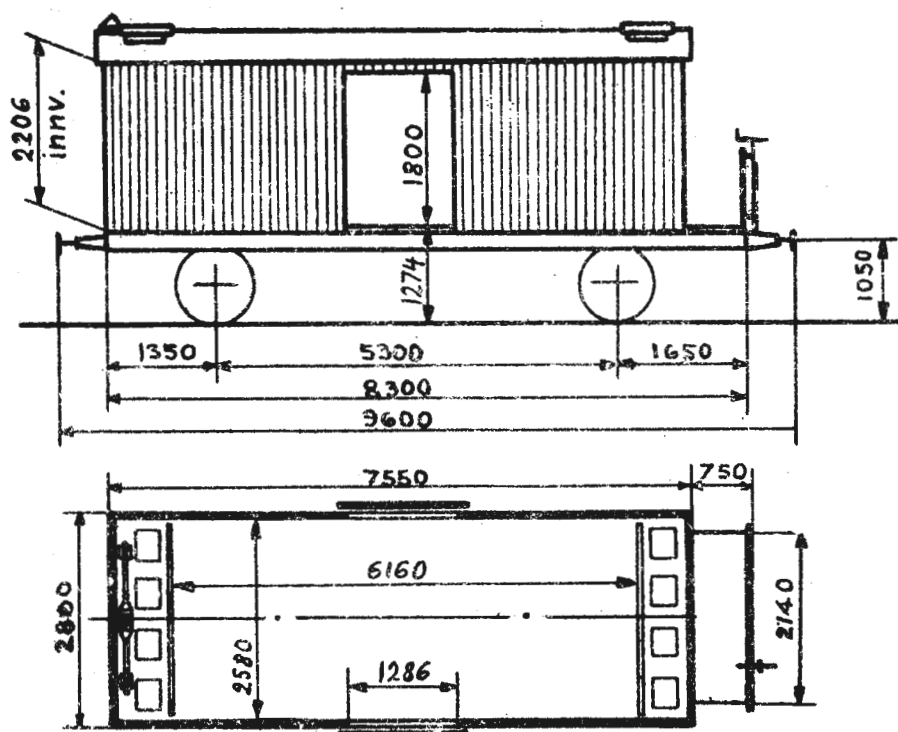

Omtrentlig vognvekt 14,0-16,0 t 1)
 " bæreevne 14,0-15,5 t 2)
 Gulvflate 15,8 m²
 Rominnhold 32,4 m³
 Hovedtegning 3160 + skisse nr. 1085

Vg. har rullelager og 12,0 t bæreevne som S-vogn.

KJÖLE- OG VARMEVOGN

Vogn nr.	Fabr.	Byggeår	Merknad	Vogn nr.	Fabr.	Byggeår	Merknad
70000	Skb	30					
70015	"	31					

1) Med tomme isbeholdere. 2) Inklusive is.

Trykk nr. 752 1.1.68

Hvf 4

TYPE 2

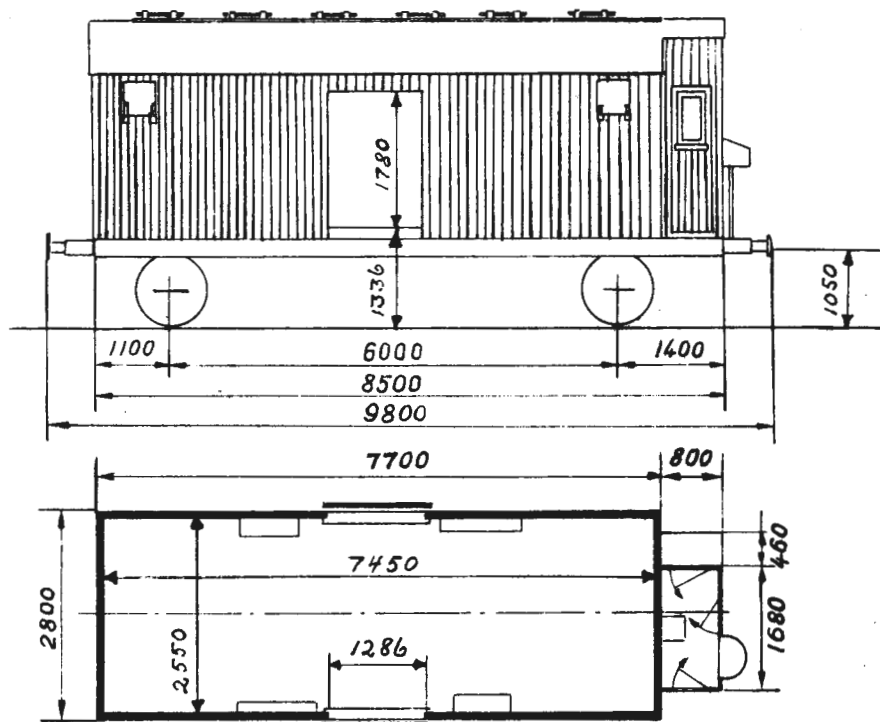

Vg. har rullelager og 12,0 t bæreevne som S-vogn.

Omtrentlig vognvekt	14,0 t 1)
" bæreevne	16,0 t 2)
Gulvflate	18,7 m ²
Rominnhold	35,6 m ³
Hovedtegning	5130

KJÖLE- OG VARMEVOGN

Vogn nr.	Fabr.	Byggeår	Merknad	Vogn nr.	Fabr.	Byggeår	Merknad
70033	Skb	47	3)				
70052	Str	45	3)				

1) Med tomme isbeholdere. 2) Inklusive is. 3) Benyttes for transport av matvarer, unntatt fisk.

1.1 6²

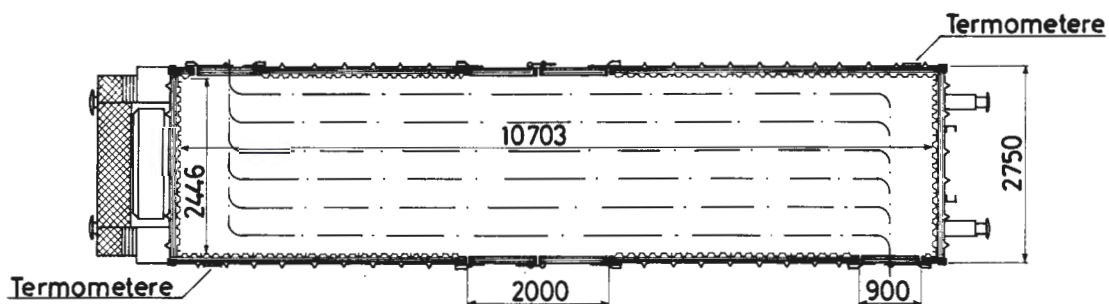
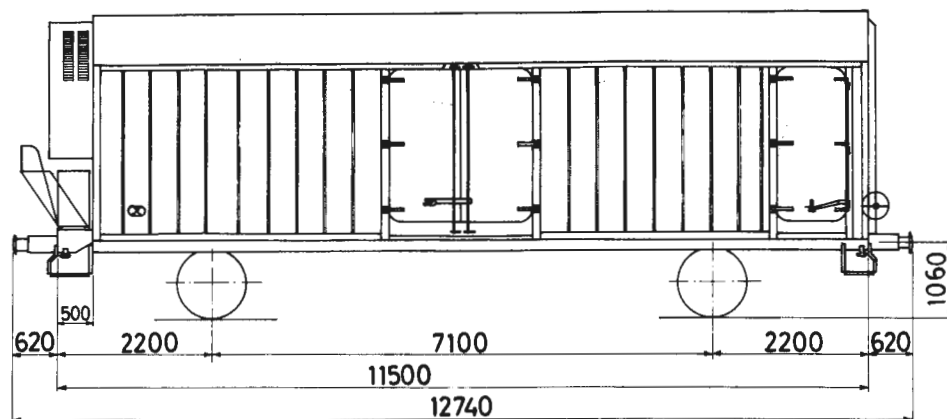

Bæreevne

	A	B	C
	14,5 t	18,5t	22,5t
S	14,5 t	18,5 t	

Omtrentlig vognvekt 17,5 t
 Gulvflate 26,2 m²
 Rominnhold 54,0 m³
 Hovedtegning 15548

Kjölevogn

Vogn nr.	Fabr.	Byggeår	Merknad	Vogn nr.	Fabr.	Byggeår	Merknad
21 76 818 1011-5	Mbg	67					
818 1012-3	"	"					
818 1013-1	"	"					
818 1014-9	"	"					
818 1015-6	"	"					
818 1016-4	"	"					

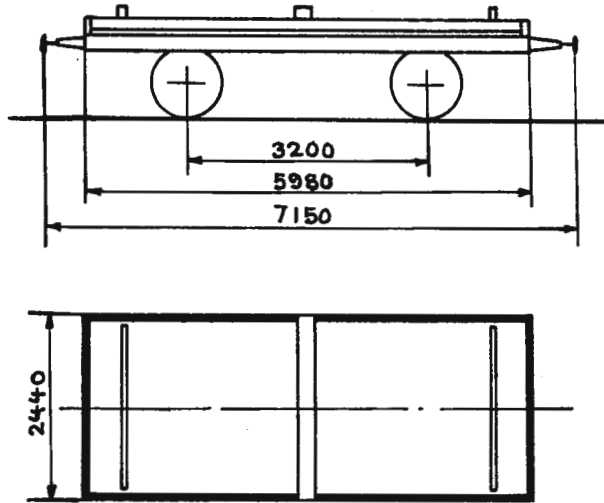
K1**TYPE 1**

Omtrentlig vognvekt	5,0 t
" last	11,5 t
Gulvflate	13,3 m ²
Rommehold	1,6 m ³
Hovedtegning	Ukjent

TÖMMERVOGN

Vogn nr.	Fabr.	Byggeår	Merknad	Vogn nr.	Fabr.	Byggeår	Merknad
2153	Str	75					
2158	"	"					
2160	"	"					

Vognene er ombygd i Oslo distrikt 1903-06.

Trykk nr. 752 1.1.61

K1

TYPE 2

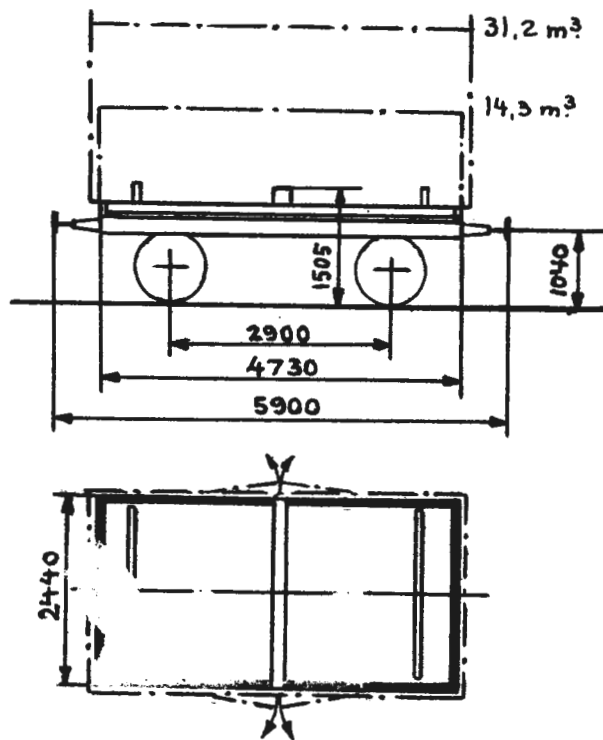

Omtrentlig vognvekt 5,0- 6,0 t
 " last 11,0-11,5 t²
 Gulvflate 10,6 m²
 Rominnhold -
 Hovedtegning 138

TÖMMERVOGN

Vogn nr.	Fabr.	Byggeår	Merknad	Vogn nr.	Fabr.	Byggeår	Merknad
1384	Str	97	1)				
2177	Oslo	99	1)				
2181	Skb	91	2)				
2201	Oslo	04	2)				
2240	"	01	1)				
2260	"	04	2)				

1) Rominnhold 31,2 m³. 2) Rominnhold 1,3 m³.

K1
TYPE 3

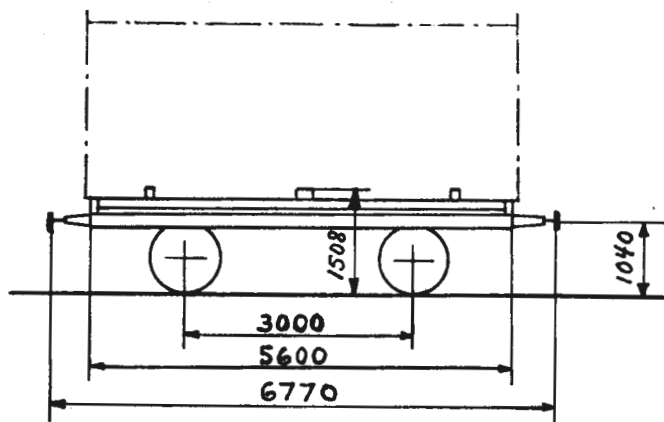

Omtrentlig vognvekt 5,5 t
 " last 10,5-11,0 t
 Gulvflate 15,0 m²
 Rominnhold 35,5 m³ 1)
 Hovedtegning B 119

TÖMMERVOGN

Vogn nr.	Fabr.	Byggeår	Merknad	Vogn nr.	Fabr.	Byggeår	Merknad
1313	Str	03					

1) Med kasse for treavfall.

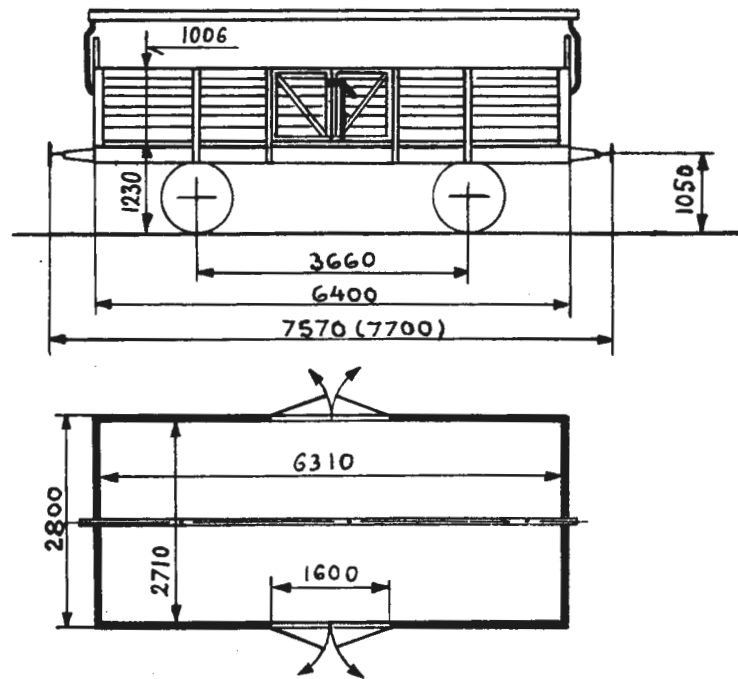

Bæreevne

A	B	C
16,5t	16,5t	

Omtrentlig vognvekt 6,5-8,0 t
 Gulvflate 17,0 m²
 Rominnhold 17,0-18,7 m³
 Hovedtegning 1070, 1519, 1708
 eller 5567+1519

KASSEVOGN

Vogn nr.	Fabr.	Byggeår	Merknad	Vogn nr.	Fabr.	Byggeår	Merknad
3174	Skb	26	H-tegn. 5567+1519	3703	Oslo	22	
3393	"	25	1)	3708	"	24	
				3709	"	"	
			H-tegn. 1519	3711	"	"	
3662	AaB	24		3712	"	"	
3665	"	"		3717	"	"	
3666	"	25		3719	"	"	
3667	"	"		3720	"	22	
3669	"	"		3721	"	24	
3676	Str	23		3722	"	22	
3681	"	"		3723	"	24	
3682	"	"		3724	"	"	
3684	"	"		3726	"	"	
3689	"	"		3728	"	28	
3701	Oslo	"		3729	"	"	

1) Opprinnelig hovedtegn. 376.

Vogn nr.	Fabr.	Byggeår	Merknad	Vogn nr.	Fabr.	Byggeår	Merknad
3730	Oslo	28		6937	Skb	21	
3746	"	13		6938	"	"	
3791	Str	23		6942	"	"	
3792	"	"		6945	"	"	
3794	"	"		6948	"	"	
3795	"	"		6949	"	"	
3797	"	"		6951	"	"	
3798	"	"		8383	Str	23	
3800	"	"		10572	Skb	21	
5408	"	24		10573	"	"	
5409	"	"		10574	"	"	
5411	"	"		10576	"	"	
5414	"	"		10578	"	"	
5417	"	"		10581	"	"	
5418	"	"		10582	"	"	
5419	"	"		10584	"	"	
5420	"	"		10586	"	"	
5422	"	"		10588	"	"	
5424	"	"		10590	"	"	
5427	AaB	25		12815	Str	16	
5429	"	"		12816	"	24	
5431	"	"		12819	"	"	
5432	"	"		12820	"	"	
5433	"	"		12822	"	"	
5434	"	"		12824	"	"	
5436	"	"		12825	"	"	
			H-tegn. 5567 + 1519	12827	"	"	
5465	Skb	27	1)	12832	"	"	
			H-tegn. 1519	12836	"	"	
5632	HJ	13		12843	AaB	25	
6932	Skb	21		12845	"	"	
6934	"	"		12847	"	"	
6935	"	"		12848	"	"	
6936	"	"		12850	"	"	
				12851	"	"	

1) Opprinnelig hovedtegn. 376.

Vogn nr.	Fabr.	Byggeår	Merknad	Vogn nr.	Fabr.	Byggeår	Merknad
12854	AaB	25		15856	Skb	21	
			H-tegn. 5567+1519	15857	"	"	
14210	Skb	24	1)	15858	"	"	
			H-tegn. 1070 2)	15859	"	"	
15718	MMV	10		15860	"	"	
15741	AaB	"		15865	"	"	
15757	"	"		15868	"	"	
				15870	"	"	
			H-tegn. 1519	15932	Str	23	
15809	Skb	21		15933	"	"	
15814	"	"		15934	"	"	
15817	"	"		15935	"	"	
15818	"	"		15938	"	"	
15819	"	"		15939	"	24	
15820	"	"		15940	"	"	
15823	"	"		15941	"	"	
15824	"	"		15942	"	"	
15826	"	"		15945	"	"	
15828	"	"		15947	"	"	
15829	"	"		15969	"	"	
15830	"	"		15970	"	"	
15832	"	"		15971	"	"	
15833	"	"		15972	"	"	
15834	"	"		15975	"	"	
15836	"	"		15977	AaB	25	
15838	"	"		15979	"	"	
15839	"	"		15982	"	"	
15840	"	"		15983	"	"	
15842	"	"		15984	"	"	
15843	"	"		15988	"	"	
15845	"	"		16573	Skb	28	
15846	"	"		16574	"	"	
15848	"	"		16575	"	"	
15850	"	"		16576	"	"	
15851	"	"		16577	"	"	

1) Opprinnelig hovedtegn. 376. 2) Gulvhøyde 1218 mm.

Vogn nr.	Fabr.	Byggeår	Merknad	Vogn nr.	Fabr.	Byggeår	Merknad
16578	Skb	28					
16579	"	"					
16584	"	"					
17170	Str	21					
20026	HJ	13					
20034	"	"					
20168	Edf	22					
			H-tegn. 5567+1519				
20170	Str	22					
			H-tegn. 1519				
20175	Edf	22					
20184	Str	"					
			H-tegn. 5567+1519				
20187	Str	22					
			H-tegn. 1519				
20264	AaB	25					
20265	"	"					
20266	"	"					
20267	"	"					
20268	"	"					
20270	"	"					
20271	"	"					
20272	"	"					
20273	"	"					
20745	HJ	13					
20751	"	"					

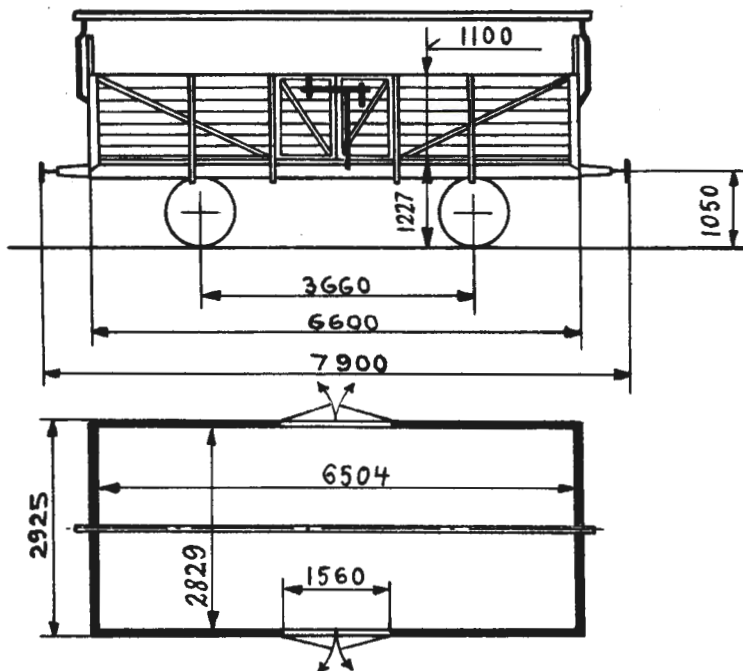

Bæreevne

A	B	C
16,5t	16,5t	

Omtrentlig vognvekt

Gulvflate

Rominnhold

Hovedtegning, oppr.

7,5 t

18,4 m²

20,2 m³

2175 1)

KASSEVOGN

Vogn nr.	Fabr.	Byggeår	Merknad	Vogn nr.	Fabr.	Byggeår	Merknad
2789	AaB	16					
2797	"	"					
15777	Skb	"					
15789	AaB	"					
15803	"	"					

1) Omb. etter tegn. D3073

L3
TYPE 7

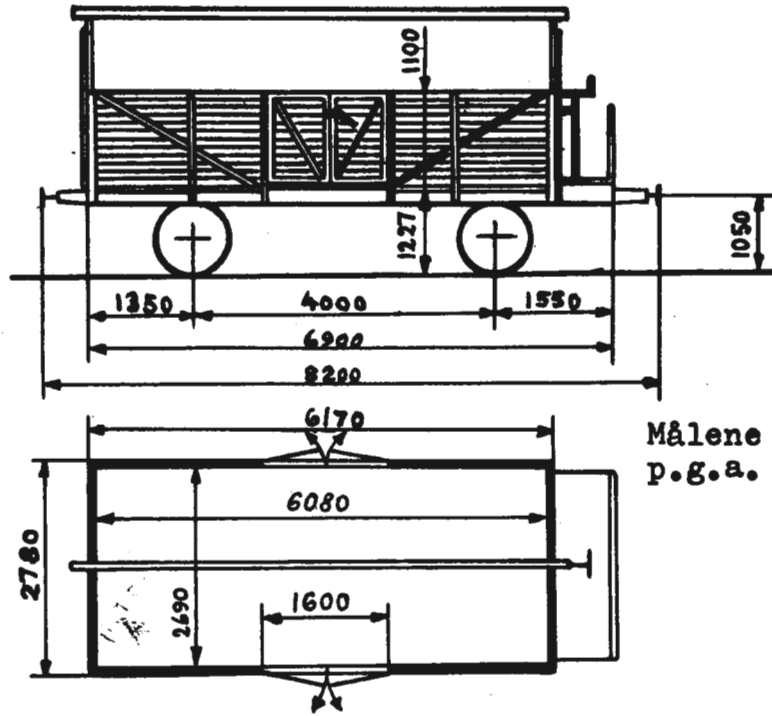

Målene er uvisse
p.g.a. ombygninger

Bæreevne

A	B	C
16,5t	16,5t	

Omtrentlig vognvekt
Gulvflate
Rominnhold
Hovedtegning

7,5 t
17,0 m²
18,7 m³
5678+5567

KASSEVOGN

Vogn nr.	Fabr.	Byggeår	Merknad	Vogn nr.	Fabr.	Byggeår	Merknad
10042	Edf	11					

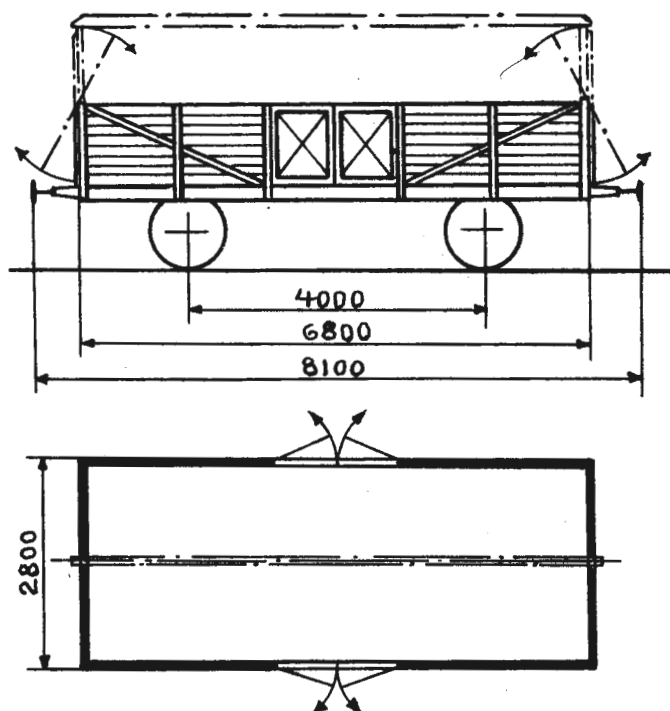

Bæreevne

A	B	C
21,0t	21,0t	

Omtrentlig vognvekt 7,0-11,0 t
 Gulvflate 18,4 m²
 Rominnhold 18,4 m³
 Hovedtegning Vognene er innkjøpt
 fra Tyskland i 1916

KASSEVOGN

Vogn nr.	Fabr.	Byggeår	Merknad	Vogn nr.	Fabr.	Byggeår	Merknad
10552		1)		11173		1)	
10553		1)		11177		1)	
10560		1)		11178		1)	
10561		1)		11182		1)	
10562		1)		11188		1)	
10565		1)		11368			
10569		1)		11369			
11153		1)		11377			
11159		1)		32125		1)	
11160		1)		32127		1)	
11163		1)		32130		1)	
11165		1)		32132		1)	
11167		1)		32133		1)	
11168		1)		32137			
11170		1)		32140		2)	

1) Presenningsbom og svingbare endevegger. 2) Vedgrind.

Vogn nr.	Fabr.	Byggear	Merknad	Vogn nr.	Fabr.	Byggear	Merknad
32145				32331			
32146		2)		32368			
32148		1)		32369			
32150		3)		32370			
32152		1)		32371			
32157		1)		32373			
32160		1)		32374			
32163		1)		32377			
32164		1)		32380			
32172		1)		32383			
32174		1)		32386			
32180		1)		32389			
32187		1)		32391			
32200				32393			
32201				32395			
32203				32401			
32207		1)		32451			
32214		4)		32454		1)	
32218				32456		1)	
32234				32457		1)	
32237				32469			
32241				32471			
32243				32474		1)	
32250				32526			
32268		1)		32550			
32277				32567			
32278				32575			
32279				32585			
32282				32609			
32289				32611			
32293				32619			
32296		1)		32635			
32299				32638			
32301				32645		1)	
32308				32664			

1) Presenningsbom og svingbare endevegger. 2) Vedgrind. 3) Svingbare endevegger. 4) Söppelkasse.

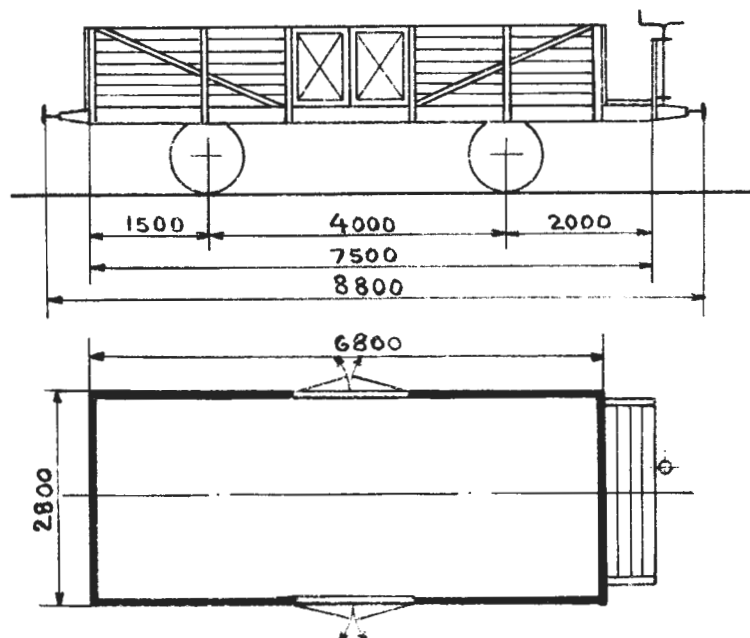

Bæreevne

A	B	C
21,0t	21,0t	

Omtrentlig vognvekt 7,0-10,0 t₂
 Gulvflate 18,4 m²
 Rominnhold 18,4 m³
 Hovedtegning Vognene er innkjøpt fra Tyskland i 1916

KASSEVOGN

Vogn nr.	Fabr.	Byggeår	Merknad	Vogn nr.	Fabr.	Byggeår	Merknad
11195				23420		1)	
11196		1)		23421		1)	
11200		1) 2)		23422		1)	
11355				32123		1)	
11361		1)		32135		1) 2)	
11365		1)		32144		1) 2)	
11383		1)		32154		1) 2)	
11385		1)		32178		1)	
11387		1)		32189		1) 2)	
11388				32254		1) 2)	
11390		1) 2)		32255		1)	
11392		1)		32256		1)	
11396		1) 2)		32259		1) 2)	
11397		1)		32260		1) 2)	
23418		1)		32261			

1) Forandret etter skisse nr. 287. 2) Presenningsbom og svingbare ndevegger.

L4
TYPE 2

Vogn nr.	Fabr.	Byggeår	Merknad	Vogn nr.	Fabr.	Byggeår	Merknad
32262							
32264			1)				
32265			1) 2)				
32266							
32267			1) 2)				
32305			1) 2)				
32306			1)				
32309			1) 2)				
32318							
32324			1) 2)				
32328			1)				
32333			1) 2)				
32346			1) 2)				
32360			1) 2)				
32361			1) 2)				
32364			1) 2)				
32450			1) 2)				
32516			1) 2)				
32523			1) 2)				
32537			1) 2)				
32555			1) 2)				
32565			1) 2)				
32569			1) 2)				
32581			1) 2)				
32588							
32598			1) 2)				
32614			1) 2)				
32616			1)				
32620			1) 2)				
32625			1) 2)				
32639			1) 2)				
32648			1) 2)				

1) Forandret etter skisse nr. 287. 2) Presenningsbom og svingbare endevegger.

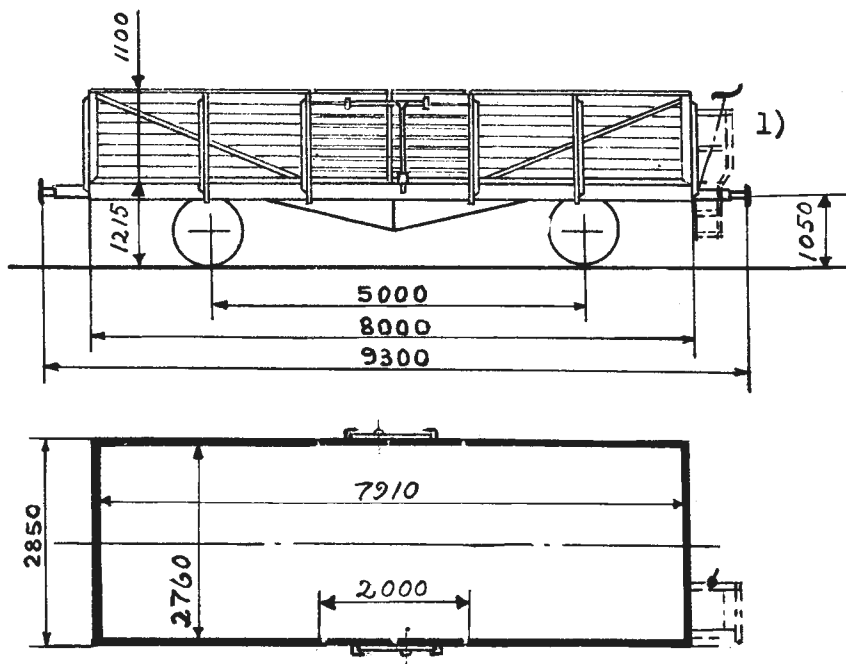

Bæreevne

A	B	C
21,0t	21,0t	

Omtrentlig vognvekt 8,0-9,0 t
 Gulvflate 21,8 m²
 Rominnhold 24,0 m³
 Hovedtegning 3989

KASSEVOGN

Vogn nr.	Fabr.	Byggeår	Merknad	Vogn nr.	Fabr.	Byggeår	Merknad
50001	Skb	36		50020	Skb	36	
✓ 50002	"	"		50022	"	"	
50003	"	"		✓ 50023	"	"	
50004	"	"		50025	Edf	37	
✓ 50005	"	"		✓ 50026	"	"	
50006	"	"		50027	"	"	
50007	"	"		✓ 50028	"	"	
50008	"	"		50029	"	"	
50009	"	"		50032	"	"	
✓ 50012	"	"		✓ 50035	"	"	
50014	"	"		✓ 50039	"	"	
✓ 50015	"	"		50041	"	"	
50016	"	"		✓ 50042	"	"	
50018	"	"		✓ 50043	"	"	
50019	"	"		50044	"	"	

1) Vognene fra nr. 50270 til nr. 50468 har bremserplattform.

Vogn nr.	Fabr.	Byggeår	Merknad	Vogn nr.	Fabr.	Byggeår	Merknad
✓50045	Str	37		50098	Str	39	
50047	"	"		50099	"	"	
50051	"	"		50100	Edf	46	
50054	"	"		50101	"	"	
✓50055	"	"		50102	"	"	
✓50056	"	"		50103	"	"	
50058	"	"		50104	"	"	
50062	"	"		50105	"	"	
50063	"	"		50106	"	"	
✓50064	"	"		50107	"	"	
50066	"	"		50108	"	"	
✓50067	"	"		50109	"	"	
✓50068	"	"		50110	"	"	
50070	"	"		50111	"	"	
50071	"	"		50112	"	"	
50072	"	"		50113	"	"	
50073	"	"		50114	"	"	
✓50074	"	"		50117	"	"	
50077	"	"		50120	"	"	
50078	"	"		50121	"	"	
✓50080	"	38		50122	"	"	
50081	"	"		50123	"	"	
50082	"	"		50124	"	"	
50083	"	"		50125	"	"	
50084	"	"		50126	"	"	
50085	"	"		50127	"	"	
50086	"	"		50128	"	"	
✓50088	"	"		50129	"	"	
50089	"	"		50130	"	"	
50091	"	39		✓50131	"	"	
50092	"	"		50132	"	"	
50093	"	"		✓50133	"	"	
✓50095	"	"		✓50134	"	"	
50096	"	"		50135	"	"	
50097	"	"		50136	"	"	

Vogn nr.	Fabr.	Byggear	Merknad	Vogn nr.	Fabr.	Byggear	Merknad
50137	Edf	46		50173	Skb	47	
50138	"	"		50174	"	"	
50139	"	"		50175	"	"	
50140	"	"		50177	"	"	
50141	"	"		50178	"	"	
50142	"	"		50179	"	"	
50143	"	"		50180	"	"	
50144	"	"		50181	"	"	
50145	"	"		50182	"	"	
50146	"	"		50183	"	"	
50147	"	"		50184	"	"	
50148	"	"		50185	"	"	
50149	"	"		50186	"	"	
50150	"	"		50187	"	"	
50151	"	"		50188	"	"	
50152	"	"		50189	"	"	
50154	"	"		50190	"	"	
50155	"	"		50191	"	"	
50156	"	"		50192	"	"	
50157	"	"		50193	"	"	
50158	"	"		50194	"	"	
50159	"	"		50195	"	"	
50160	"	"		50196	"	"	
50161	"	"		50197	"	"	
50162	"	"		50198	"	"	
50163	"	"		50199	"	"	
50164	"	"		50200	"	"	
50165	"	"		50201	"	"	
50166	"	"		50202	"	"	
50167	"	"		50203	"	"	
50168	"	"		50204	"	"	
50169	"	"		50205	"	"	
50170	Skb	47		50206	"	"	
50171	"	"		50207	"	"	
50172	"	"		50208	"	"	

Vogn nr.	Fabr.	Byggeår	Merknad	Vogn nr.	Fabr.	Byggeår	Merknad
✓-50209	Skb	48		50245	Edf	47	
✓-50210	"	"		50246	"	"	
50211	"	"		50247	"	"	
50212	"	"		50248	"	"	
✓-50213	"	"		✓-50249	"	"	
50214	"	"		✓-50250	"	"	
50215	"	"		✓-50251	"	"	
✓-50216	"	"		✓-50252	"	"	
50217	"	"		✓-50253	"	"	
50218	"	"		✓-50254	"	"	
✓-50219	"	"		✓-50255	"	"	
50220	Edf	47		✓-50256	"	"	
✓-50221	"	"		50257	"	"	
50222	"	"		✓-50258	"	"	
50223	"	"		50259	"	"	
50224	"	"		50260	"	"	
✓-50225	"	"		50261	"	"	
50227	"	"		✓-50262	"	"	
50228	"	"		50263	"	"	
50229	"	"		✓-50264	"	"	
50230	"	"		50265	"	"	
✓-50231	"	"		50266	"	"	
✓-50232	"	"		50267	"	"	
50233	"	"		50268	"	"	
50234	"	"		50269	"	"	
✓-50235	"	"		50270	Skb	50	
50236	"	"		50271	"	"	
50237	"	"		50272	"	"	
50238	"	"		50274	"	"	
✓-50239	"	"		50275	"	51	
50240	"	"		50276	"	"	
50241	"	"		50277	"	"	
✓-50242	"	"		50279	"	"	
✓-50243	"	"		50280	"	"	
50244	"	"		50281	"	"	

Vogn nr.	Fabr.	Byggeår	Merknad	Vogn nr.	Fabr.	Byggeår	Merknad
50282	Skb	51		50329	Skb	52	
50283	"	"		50330	"	"	
50285	"	"		50331	"	"	
50286	"	"		50332	"	"	
50287	"	"		50333	"	"	
50288	"	"		50334	"	"	
50289	"	"		50335	"	"	
50290	"	"		50336	"	"	
50291	"	"		50337	"	"	
50292	"	"		50338	"	"	
50293	"	"		50339	"	"	
50294	"	"		50340	"	"	
50295	"	"		50341	"	"	
50296	"	"		50343	"	"	
50297	"	"		✓ 50344	"	"	
50299	"	"		50347	"	"	
50301	"	"		✓ 50348	"	"	
50304	"	"		50349	"	"	
50305	"	"		50350	"	"	
50306	"	"		50351	"	"	
50310	"	"		50353	"	"	
50313	"	"		50354	"	"	
50314	"	"		50355	"	"	
50315	"	"		50356	"	"	
50316	"	"		50357	"	"	
50317	"	"		✓ 50358	"	"	
50318	"	"		50360	"	"	
50320	"	52		50361	"	"	
✓ 50321	"	"		50362	"	"	
50322	"	"		50363	"	"	
50323	"	"		50367	"	"	
50324	"	"		50368	"	"	
50326	"	"		50369	"	"	
50327	"	"		50370	"	"	
50328	"	"		50371	"	"	

Vogn nr.	Fabr.	Byggeår	Merknad	Vogn nr.	Fabr.	Byggeår	Merknad
50372	Skb	52		50413	Skb	52	
50373	"	"		50414	"	"	
50374	"	"		50416	"	"	
50375	"	"		50419	"	"	
50377	"	"		50420	"	"	
50378	"	"		50422	"	"	
50379	"	"		50423	"	"	
50380	"	"		50424	"	"	
50381	"	"		50425	"	"	
50382	"	"		50428	"	"	
50383	"	"		50429	"	"	
50384	"	"		50430	"	"	
50385	"	"		50432	"	"	
50386	"	"		50433	"	"	
50387	"	"		50434	"	"	
50389	"	"		50435	"	"	
50390	"	"		50436	"	"	
50391	"	"		50438	"	"	
50392	"	"		50440	"	"	
50393	"	"		50441	"	"	
50395	"	"		50442	"	"	
50397	"	"		50443	"	"	
50398	"	"		50446	"	"	
50399	"	"		50447	"	"	
50400	"	"		50448	"	"	
50401	"	"		50449	"	"	
50402	"	"		50451	"	53	
50404	"	"		50453	"	"	
50405	"	"		50455	"	"	
50406	"	"		50456	"	"	
50408	"	"		50457	"	"	
50409	"	"		50459	"	"	
50410	"	"		50460	"	"	
50411	"	"		50463	"	"	
50412	"	"		50468	"	"	

L4 type 3-vogner med internasjonal litrering og nummerering.

Vogn nr.	Fabr.	Byggeår	Merknad	Vogn nr.	Fabr.	Byggeår	Merknad
21 76 511 0005-9	Skb	36	50007	21 76 511 0248-5	Skb	51	1316
511 0019-0	Edf	37	50027	511 0249-3	"	"	1317
511 0021-6	"	"	50030	511 0250-1	"	"	1318
511 0030-7	Str	"	50031	511 0257-6	"	52	1319
511 0036-4	"	"	50032	511 0261-8	"	"	1320
511 0050-5	"	38	50033	511 0265-9	"	"	1321
511 0054-7	"	"	50034	511 0272-5	"	"	1322
511 0067-9	Edf	46	50035	511 0298-0	"	"	1323
511 0068-7	"	"	50036	511 0317-8	"	"	1324
511 0069-5	"	"	50037	511 0328-5	"	"	1325
511 0081-0	"	"	50038	511 0338-4	"	"	1326
511 0100-8	"	"	50039	511 0340-0	"	"	1327
511 0104-0	"	"	50040				
511 0119-8	"	"	50041				
511 0124-8	"	"	50042				
511 0143-8	Skb	47	50043				
511 0146-1	"	"	50044				
511 0178-4	Edf	"	50045				
511 0195-8	"	"	50046				
511 0198-2	"	"	50047				
511 0216-2	"	"	50048				
511 0222-0	"	51	50049				
511 0226-1	"	"	50050				
511 0227-9	"	"	50051				
511 0228-7	"	"	50052				
511 0229-5	"	"	50053				
511 0232-9	"	"	50054				
511 0237-8	"	"	50055				
511 0239-4	"	"	50056				
511 0240-2	"	"	50057				
511 0241-0	"	"	50058				
511 0242-8	"	"	50059				
511 0243-6	"	"	50060				
511 0245-1	"	"	50061				
511 0247-7	"	"	50062				

Lo3

TYPE 1

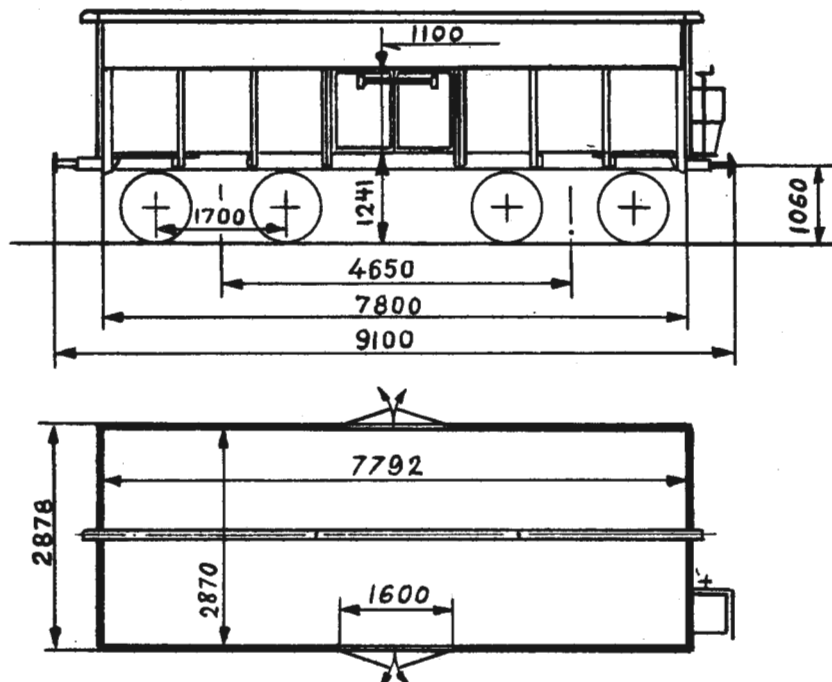

Omtrentlig vognvekt 15,0-15,5 t
 " last 30,5 t
 Gulvflate 22,4 m²
 Rominnhold 24,6 m³
 Hovedtegning 6199

KASSEVOGN

Vogn nr.	Fabr.	Byggeår	Merknad	Vogn nr.	Fabr.	Byggeår	Merknad
23701	SME	49	1)	23717	SME	49	1)
23702	"	"	1)	23718	"	"	1)
23703	"	"	1)	23719	"	"	1)
23704	"	"	1)	23720	"	"	1)
23705	"	"	1)	23721	"	"	1)
23706	"	"	1)	23722	"	"	1)
23707	"	"	1)	23723	"	"	1)
23708	"	"	1)	23724	"	"	1)
23709	"	"	1)				
23710	"	"	1)				
23711	"	"	1)				
23712	"	"	1)				
23713	"	"	1)				
23714	"	"	1)				
23715	"	"	1)				

1) Presenningsbom og svingbare endevegger.

Trykk nr. 752 1.1.64

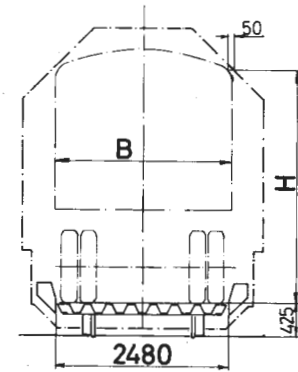
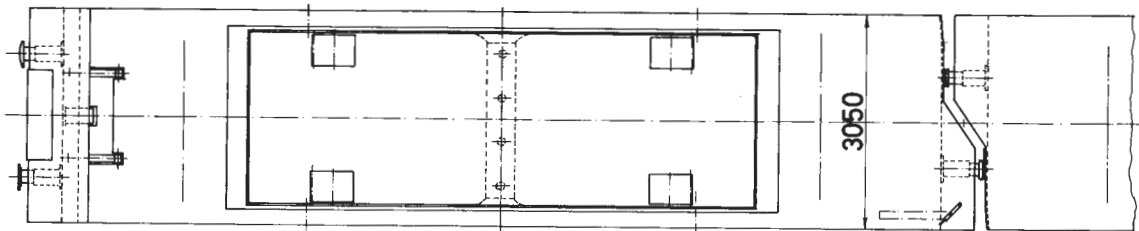
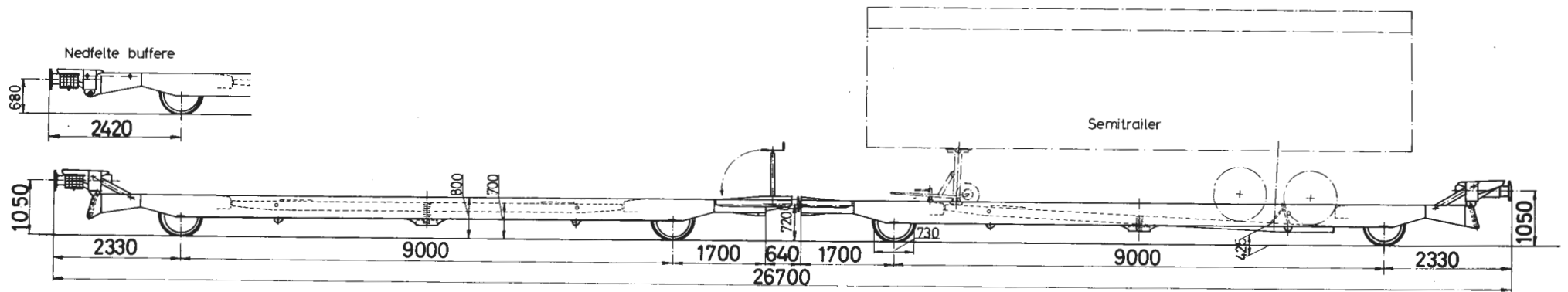

B	H
2400	3350
2350	3375

Bæreevne pr. vogn

	A	B	C
	21,0 t	25,0 t	29,0 t
S	21,0 t	25,0 t	29,0 t

Bæreevne pr. enhet

	A	B	C
	42,0 t	50,0 t	58,0 t
S	42,0 t	50,0 t	58,0 t

Omtrentlig vognvekt pr. vogn 23,4 t

" " " enhet 11,7 t

Gulvflate " " 80,0 m²

Hovedtegning Talbot, AZ 14773b

SEMISTRILERTRANSPORTVOGN

Vogn nr.	Fabr.	Byggeår	Merknad	Vogn nr.	Fabr.	Byggeår	Merknad
20 76 430 5000-9	Tal b	65					

Trykk nr. 752 1.1.68

Laas

Lf3

TYPE 1

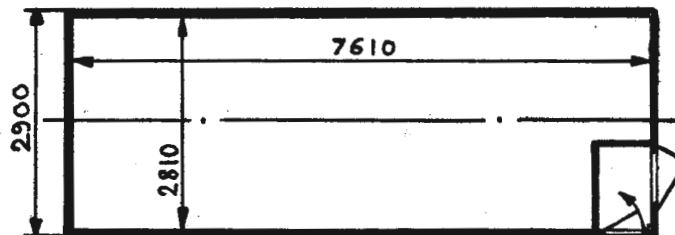
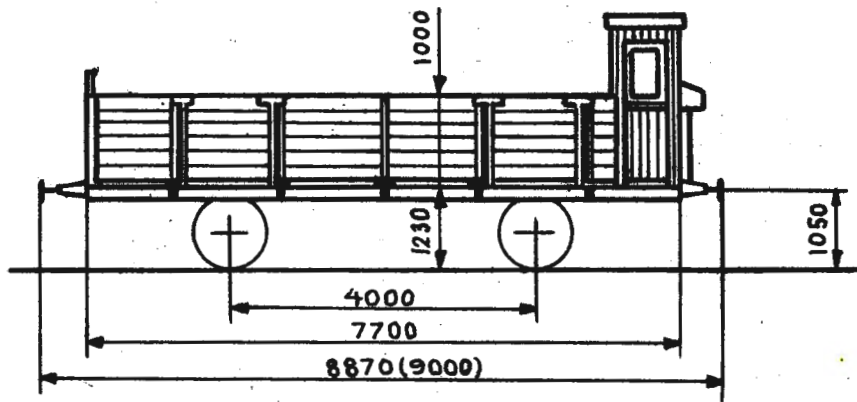

Omtrentlig egenvekt	8,5	t.
" last	14,5	t.
Gulvflate	20,5	m ²
Rominnhold	20,4	m ³
Hovedtegning	578	

KASSEVOGN

Vogn nr.	Fabr.	Byggear	Merknad	Vogn nr.	Fabr.	Byggear	Merknad
13001	Skb	01					
13002	"	"					
13077	Edf	17					
13078	"	"					
13079	"	"					
13084	Str	22					
13085	"	"					

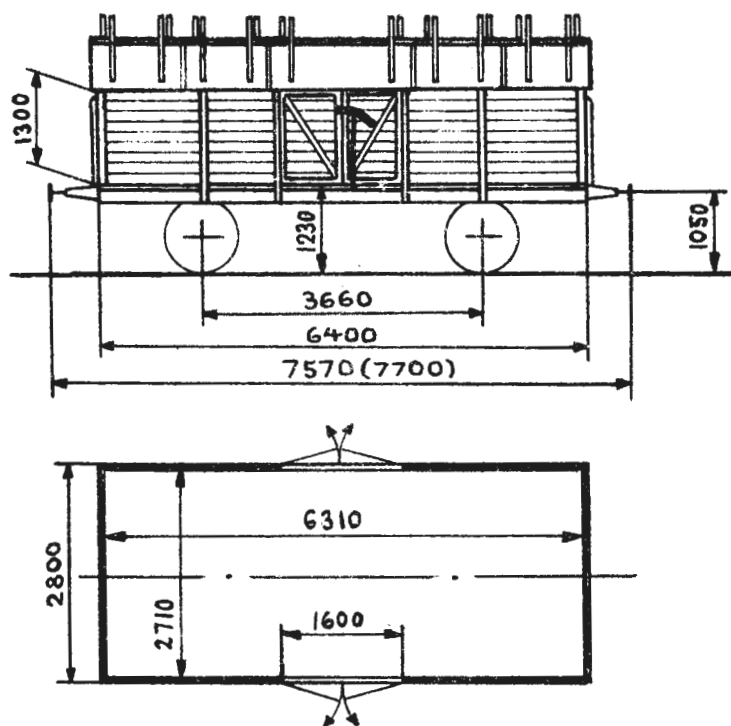

Bæreevne

A	B	C
15,5t	15,5t	

Omtrentlig vognvekt 8,0 t₂
 Gulvflate 17,0 m²
 Rominnhold 26,5 m³
 Hovedtegning 1133 eller 1708

KALKVOGN

Vogn nr.	Fabr.	Byggeår	Merknad	Vogn nr.	Fabr.	Byggeår	Merknad
			H-tegn. 1708				
6711	Str	16		10652	Str	14	
6712	"	"		10653	"	"	
6713	"	"		10655	"	"	
6714	"	"					H-tegn. 1133
6715	"	"		15901	Str	10	
6726	Edf	17		15902	"	"	
6727	"	"		15903	"	"	
6728	"	"		15905	"	"	
6729	"	"		15906	"	"	
6730	"	"		15909	"	"	
10102	Str	27					H-tegn. 1708
10103	"	"		15911	Edf	22	
10104	"	"		15912	"	"	
10105	"	"		15913	"	"	

Lk3
TYPE 1

Vogn nr.	Fabr.	Byggear	Merknad	Vogn nr.	Fabr.	Byggear	Merknad
15920	Edf	22					
15924	"	"					
15925	"	"					
15930	"	"					
16509	Str	27					
16512	"	"					
16515	"	"					

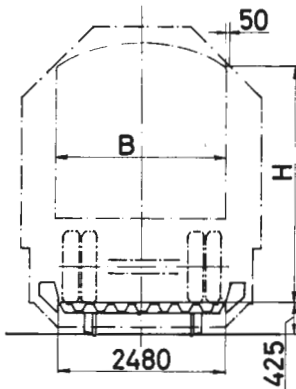
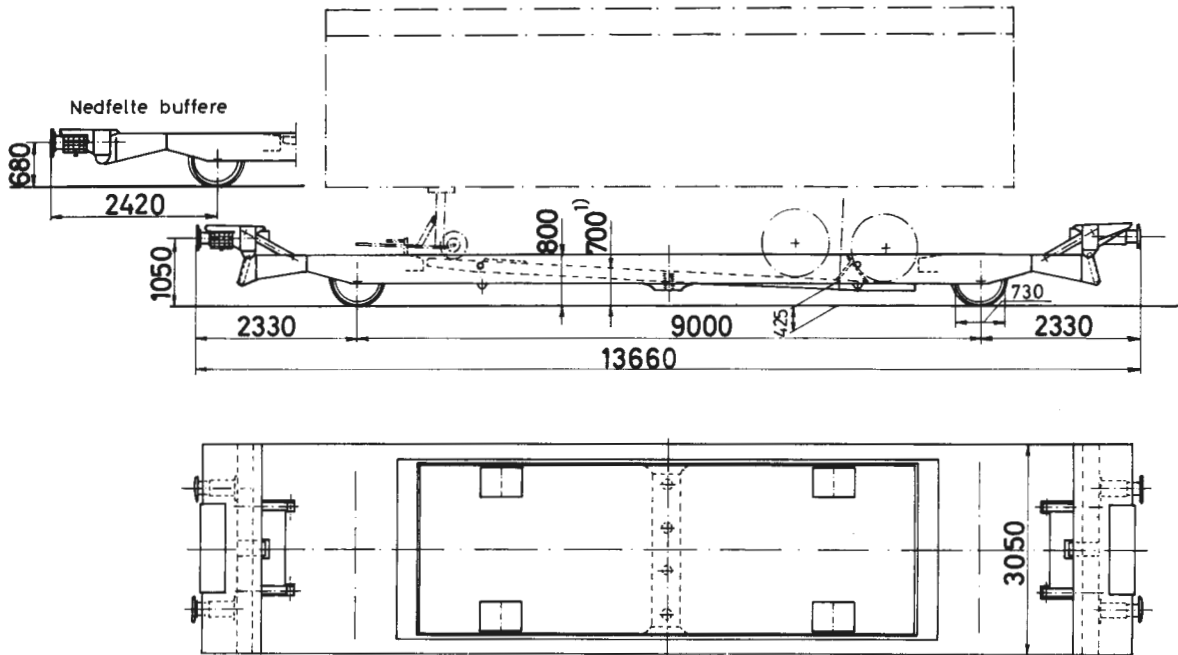

B	H
2400	3400
2350	3425

Bæreevne

	A	B	C
	19,5t	23,5t	27,5t
S	19,5t	23,5t	27,5t

Omtrentlig vognvekt 12,5t

Gulvflate 28,0m²

Hovedtegning Talbot, AZ 18721

SEMITRAILERTRANSPORTVOGN

Vogn nr.	Fabr.	Byggeår	Merknad	Vogn nr.	Fabr.	Byggeår	Merknad
20 76 410 0001-4	Sun	67	1)				
410 0002-2	"	"	1)				
410 0003-0	"	"	1)				
410 0004-8	"	"	1)				
410 0005-5	"	"					
410 0006-3	"	"					
410 0007-1	"	"					

1) Festeordninger for husseksjoner.

Lt 2
TYPE 3

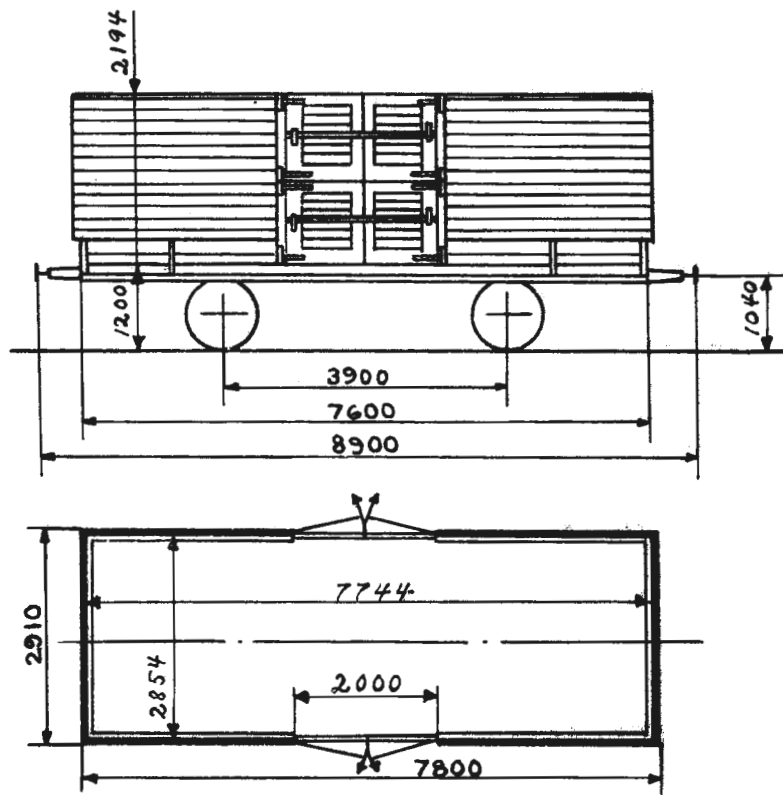

Bæreevne

A	B	C
11,0t	11,0t	

Omtrentlig vognvekt 6,5- 8,0 t
 Gulvflate 18,9 m²
 Rominnhold 45,7 m³
 Hovedtegning 815 + 3858

TREKULLVOGN

Vogn nr.	Fabr.	Byggeår	Merknad	Vogn nr.	Fabr.	Byggeår	Merknad
7616	Str	08		7700	AaB	09	
7619	"	"		7704	"	"	
7620	"	"		7714	Str	07	
7627	"	"		7725	"	08	
7629	"	"		7726	"	"	
7630	"	"		7730	"	"	
7637	"	"		7732	"	"	
7639	"	"		7733	"	"	
7644	"	"		7734	"	"	
7649	"	"		7735	"	"	
7654	"	"		7745	"	"	
7662	"	"					
7666	"	"					
7671	"	"					
7687	"	10					

Lt4

TYPE 1

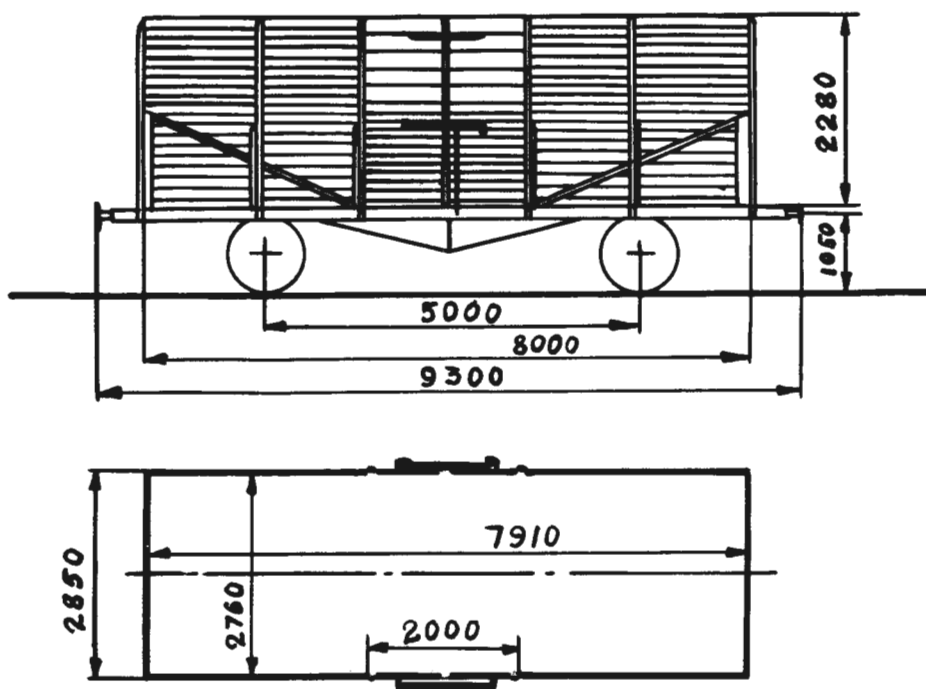

Bæreevne

A	B	C
20,0t	20,0t	

Omtrentlig vognvekt 9,0-10,0 t
 Gulvflate 21,4 m²
 Rominnhold 48,0 m³
 Hovedtegning 3989 + skisse
 nr. 1518

TREKULLVOGN

Vogn nr.	Fabr.	Byggeår	Merknad	Vogn nr.	Fabr.	Byggeår	Merknad
7100	Skb	36		7115	Str	39	
7101	Str	37		7116	"	37	
7102	Edf	"		7117	Skb	36	
7103	Str	39		7118	Str	37	
7104	"	37		7119	"	"	
7105	Edf	"		7120	"	"	
7106	Skb	36		7121	"	"	
7107	Edf	37		7122	"	"	
7108	Str	"		7123	Edf	"	
7109	"	"		7124	Str	"	
7110	"	"		7125	Skb	36	
7111	"	38		7126	Edf	37	
7112	Skb	36		7127	Skb	36	
7113	Str	37		7128	Edf	37	
7114	Skb	36		7129	Str	"	

Trykk nr. 752 1.1.60

Vogn nr.	Fabr.	Byggear	Merknad	Vogn nr.	Fabr.	Byggear	Merknad
7130	Edf	37					
7131	Skb	36					
7132	"	"					
7133	Str	39					
7134	Edf	47					
7135	Skb	36					
7136	"	47					
7137	Edf	46					
7138	Skb	47					
7139	Edf	"					
7140	"	"					
7141	Str	38					
7142	Edf	47					
7143	"	"					
7144	Skb	"					
7145	Edf	"					
7146	Str	37					
7147	"	"					
7148	Skb	47					
7149	"	"					
7150	Str	37					
7151	Edf	"					
7152	"	"					
7153	Str	"					
7154	"	"					
7155	Skb	47					
7156	Edf	"					
7157	Str	37					
7158	Edf	47					
7159	Skb	"					

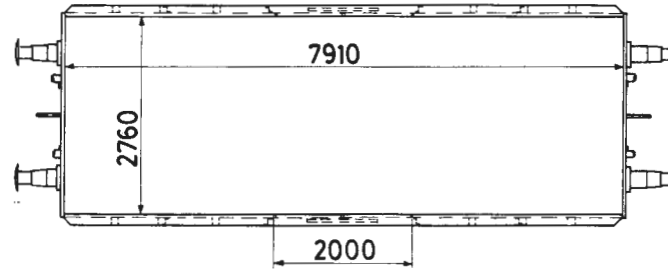
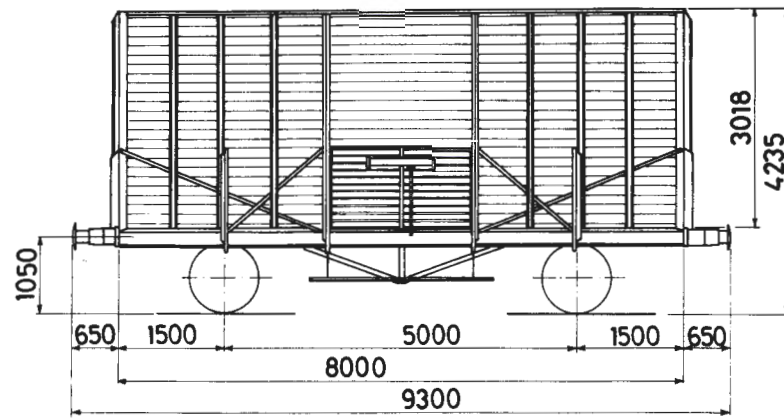

Bæreevne

A	B	C
20,0 t		

Omtrentlig vognvekt 10,0 - 10,5 t

Gulvflate 21,8 m²

Rominhold 60,0 m³

Hovedtegning 15680¹⁾

Flisvogn

Vogn nr.	Fabr.	Byggeår	Merknad	Vogn nr.	Fabr.	Byggeår	Merknad
50015	Skb	36		50221	Edf	47	
50039	Edf	37		50225	"	"	
50043	"	"		50231	"	"	
50055	Str	"		50235	"	"	
50074	"	"		50243	"	"	
50088	"	38		50250	"	"	
50097	"	39		50253	"	"	
50131	Edf	46		50256	"	"	
50133	"	"		50258	"	"	
50138	"	"		50264	"	"	
50144	"	"		50316	Skb	51	
50156	"	"					
50165	"	"					
50166	"	"					
50168	"	"					
50175	Skb	47					
50209	"	48					
50210	"	"					
50216	"	"					

¹⁾ Oppr. hovedt. 3989.

Lto 2

Type 1

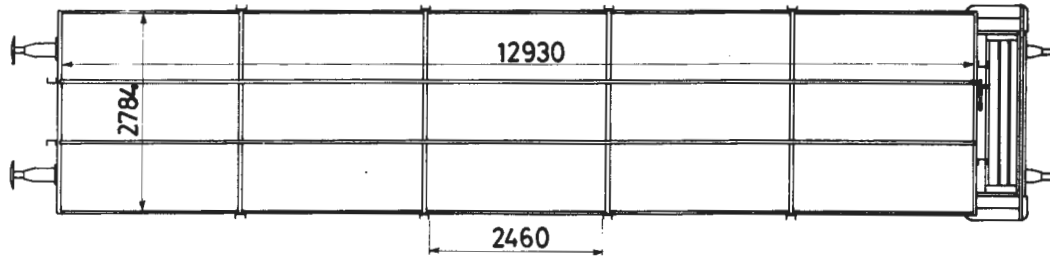
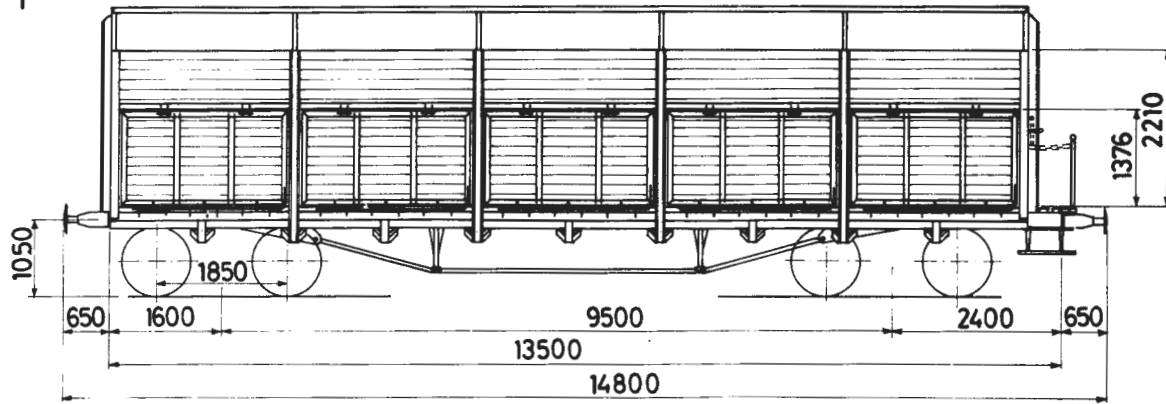

Bæreevne

A	B	C
18,0 t		

Omtrentlig vognvekt 16,0 t
 Gulvflate 36,0 m²
 Rominnhold 79,5 m³
 Hovedtegning 16044¹⁾

Flisvogn

Vogn nr.	Fabr.	Byggeår	Merknad	Vogn nr.	Fabr.	Byggeår	Merknad
3402	Str	25					

1) Oppr. hovedt. 2898. Omb. fra Gfo2-vg.
 i Krs 1967.

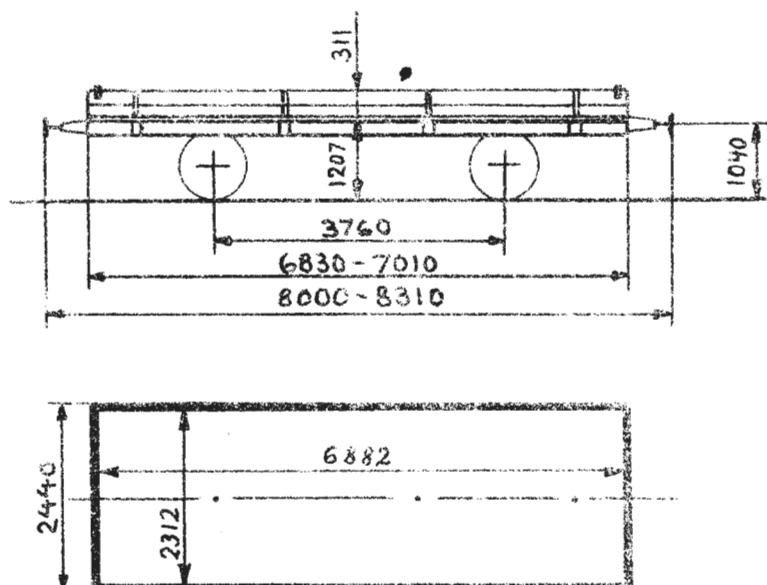

Bæreevne

A	B	C
12,0t	12,0t	

Omtrentlig vognvekt 5,0- 6,0 t
 Gulvflate 15,5-15,9 m²
 Rominnhold 4,8- 5,0 m³
 Hovedtegning 47, 400, Oslo dist-
 rikt 678, 876, B 97
 eller ukjent

GRUSVOGN

Vogn nr.	Fabr.	Byggeår	Merknad	Vogn nr.	Fabr.	Byggeår	Merknad
2267	Skb	00	H-tegn. 400	2370	Skb	04 2)	
2272	"	"					H-tegn. ukjent
2299	"	"	1)	2373	Str	01	
2362	Oslo	04	H-tegn. Oslo dist- rikt 678	2374	Skb	04 2)	H-tegn. Oslo dist- rikt 678
2363	"	05	2)	2375	Oslo	" 2)	
2365	Str	01	H-tegn. ukjent	2376	Str	01	H-tegn. ukjent
2366	Oslo	04	H-tegn. Oslo dist- rikt 678	2384	Oslo	06	
2368	"	"	2)	2385	Str	01	
2369	Skb	"	2)	2389	"	"	
				2390	Oslo	05 2)	H-tegn. Oslo dist- rikt 678

1) Omb. etter tegn. 538. 2) Har skrubremse.

Vogn nr.	Fabr.	Byggeår	Merknad	Vogn nr.	Fabr.	Byggeår	Merknad
2392	Oslo	06	H-tegn. ukjent	6366	Str	97	
2395	Str	01		6378	Skb	00	1)
2398	"	"		6383	"	"	
2442	Str	99	H-tegn. 400	8655	HJ	14	1)
2447	"	"		8667	"	"	
2452	"	"					H-tegn. 876
2473	Skb	85	H-tegn. 47	9501	Str	99	
2511	Atl	74	H-tegn. ukjent	9504	"	"	
2522	"	"		9505	"	"	
2526	"	"		9506	"	"	
2536	"	"					H-tegn. 400
2582	Skb	89	H-tegn. 47	10373	Skb	15	
2656	Str	97	H-tegn. 400	10374	"	"	
2685	"	98		10375	"	"	
2702	"	"	1)	10376	"	"	
2765	MMV	99		10377	"	"	
3804	Skb	95	3)	10378	"	"	
3806	"	"	3)	10380	"	"	
3811	"	"	3)	10381	"	"	
3812	"	"	3)	10384	"	"	
3818	"	"	3)	10386	"	"	
5277	Str	00		10388	"	"	
6142	Skb	02		10391	"	"	
6146	"	"		10392	"	"	
6156	"	"	1)	10394	"	"	
6166	"	"		10395	"	"	
6345	Str	97		10397	"	"	
				10398	"	"	
				10400	"	"	
							H-tegn. B 97
				11501	Str	00	
				11502	"	"	
				11503	"	"	

1) Omb. etter tegn. 538. 3) Byggeår 1895 eller tidligere.

Vogn nr.	Fabr.	Byggear	Merknad	Vogn nr.	Fabr.	Byggear	Merknad
11505	Str	00					H-tegn. 400
11507	"	"		16162	Edf	00	
11508	"	"		16167	"	"	
11509	"	"		16202	"	01	
11510	"	"		16212	"	"	
11512	"	"		16239	"	"	
11513	"	"		16240	"	"	
11514	"	"		16248	"	"	
11515	"	"		16249	"	"	
11516	"	"		16254	"	"	
11517	"	"		16260	"	"	1)
11518	"	"		16272	"	06	
11521	"	"					H-tegn. 876
11522	"	"		16450	AaB	12	
11524	"	"		16457	"	"	
11525	"	"		20800	Skb	21	1)
11526	"	"		20802	4)	"	
11527	"	"		20803	"	"	
11530	"	"		20804	"	"	
			H-tegn. 400	20806	"	"	
12510	Str	00	2)	20807	"	"	
			H-tegn. 47	20808	"	"	
16002	Str	92		20809	"	"	
			H-tegn. 400	20811	"	"	
16003	Str	99		20812	Skb	"	
			H-tegn. 47	20813	4)	"	
16006	KvB	93		20814	Skb	"	1)
16012	Str	"		20816	"	"	
			H-tegn. 400	20817	4)	"	
16020	Str	99		20819	Edf	22	
			H-tegn. 47	20820	"	"	
16021	KvB	93		20822	"	"	
				20824	"	"	
				20825	"	"	
				20829	"	"	

1) Omb. etter tegn. 538. 2) Har skruebremse. 4) Edf/Skb.

M1
TYPE 1

Vogn nr.	Fabr.	Byggeår	Merknad	Vogn nr.	Fabr.	Byggeår	Merknad
20830	Edf	22					
20832	"	"					
20834	4)	"					
20835	Edf	"					
20838	4)	"					
20840	Edf	"					
20841	"	"	1)				
20845	4)	"					
20847	"	"					
20848	Edf	"					
20849	"	"					

1) Omb. etter tegn. 538. 4) Edf/Skb.

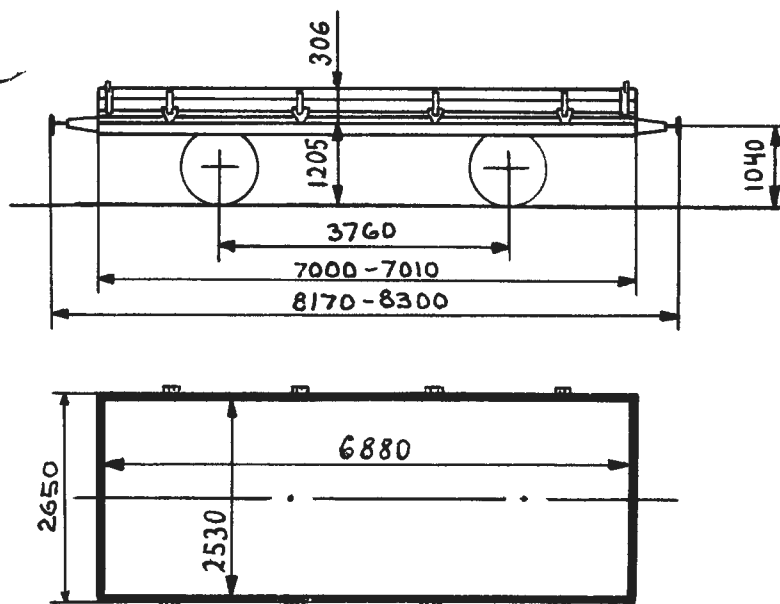

Bæreevne

A	B	C
12,0t	12,0t	

Omtrentlig vognvekt 5,5- 6,0 t
 Gulvflate 17,4 m²
 Rominnhold 4,9- 5,3 m³
 Hovedtegning 614 eller 1362

GRUSVOGN

Vogn nr.	Fabr.	Byggeår	Merknad	Vogn nr.	Fabr.	Byggeår	Merknad
			H-tegn. 1362	8259	Edf	12	
8244	Edf	12		8260	"	"	
8245	"	"		8261	"	"	
8246	"	"		8262	"	"	
8247	"	"		8263	"	"	
8248	"	"		8265	"	"	
8249	"	"		8266	"	"	
8250	"	"		8267	"	"	
8251	"	"		8268	"	"	
8252	"	"		8269	"	"	
8253	"	"		8270	"	"	
8254	"	"		8271	"	"	
8255	"	"		8272	"	"	
8256	"	"		8273	"	"	
8258	"	"		8274	"	"	

Vogn nr.	Fabr.	Byggeår	Merknad	Vogn nr.	Fabr.	Byggeår	Merknad
8275	Edf	12		14453	Edf	05	
8276	"	"		14454	"	"	
8277	"	"		14455	"	"	
8278	"	"		14456	"	"	
8279	"	"		14457	"	"	
8280	"	"		14458	"	"	
8281	"	"		14460	"	"	
8282	"	"		14461	"	"	
			H-tegn. 614	14462	"	"	
14401	Str	04		14463	"	"	
14402	"	"		14465	"	"	
14403	"	"		14467	"	"	
14404	"	"					H-tegn. 1362
14405	"	"		20501	Edf	13	
14407	"	"	1)	20502	"	"	
14408	"	"		20503	"	"	
14409	"	"		20505	"	"	
14410	"	"		20507	"	"	
14412	"	"		20508	"	"	
14413	"	"		20510	"	"	
14414	"	"		20511	"	"	
14417	"	"	1)	20512	"	"	
14419	"	"	1) 1)	20513	"	"	
14423	Skb	05		20514	"	"	
14424	"	"		20515	"	"	
14426	"	"		20516	"	"	
14428	"	"		20517	"	"	
14430	"	"		20519	"	"	
14431	"	"		20520	"	"	
14433	"	"		20522	"	"	
14434	"	"		20523	"	"	
14435	"	"		20524	"	"	
14446	Edf	06	1)	20525	"	12	1)
14450	"	05		20527	"	"	1)
14452	"	"					

1) Har skrubremse.

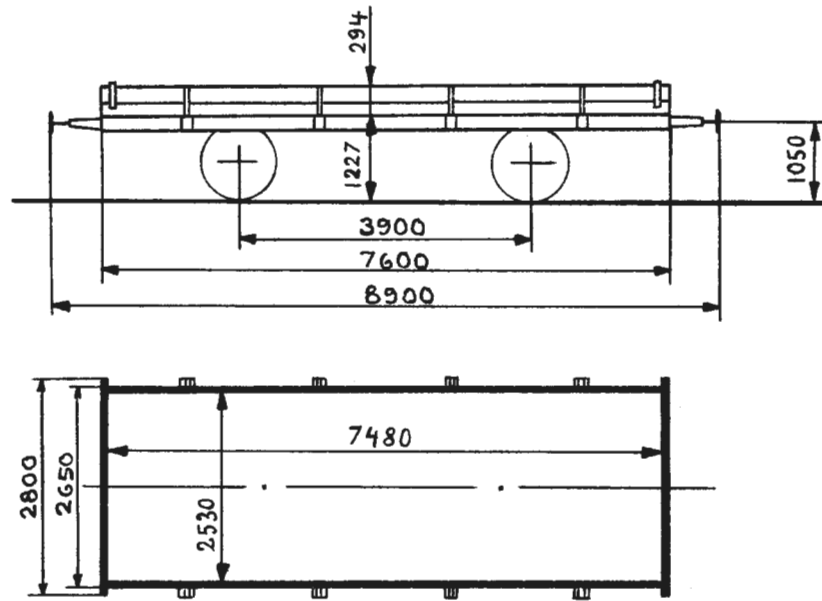

Bæreevne

A	B	C
11,0t	11,0t	

Omtrentlig vognvekt 6,0-7,0 t
 Gulvflate 19,0 m²
 Rominnhold 5,0 m³
 Hovedtegning 1255, 1334+1849
 eller 1334+1850

GRUSVOGN

Vogn nr.	Fabr.	Byggeår	Merknad	Vogn nr.	Fabr.	Byggeår	Merknad
5490	Skb	15	H-tegn. 1334+1849 ¹⁾ 3)	17518	Str	14	
5495	"	"	2) 3)	17519	"	"	
5496	"	"	2) 3)	23008	AaB	" 2)	
5498	"	"	3)	23009	"	" 2)	
8221	Str	11	H-tegn. 1255	23010	"	" 2)	
17510	Str	14	H-tegn. 1334+1850	23011	"	" 2)	
17511	"	"		23012	"	" 2)	
17512	"	"		23014	"	" 2)	
17513	"	"		23015	"	" 2)	
17515	"	"		23016	"	"	
17516	"	"		23017	"	" 2)	
17517	"	"		23018	"	"	
				23019	"	"	
				23020	"	"	
				23021	"	"	

1) Bremserhus som vist på tegn. 1849 er fjernet. 2) Platekledt varegulv. 3) Har skruebremse.

M2
TYPE 1

Vogn nr.	Fabr.	Byggeår	Merknad	Vogn nr.	Fabr.	Byggeår	Merknad
23022	AaB	14					H-tegn. 1334+1849 ¹⁾
23023	"	"		23461	Skb	15	3)
23025	"	"		23468	"	"	3)
23026	"	"		23475	"	"	3)
23027	"	"		23478	"	"	3)
23028	"	"		23484	"	"	3)
23029	"	"		23493	"	"	3)
23030	"	"					
23031	"	"					
23032	"	"					
23033	"	"					
23034	"	"					
23035	"	"					
23036	"	"					
23037	"	"					
23038	Str	"					
23039	"	"					
23040	"	"					
23442	"	"					
23443	"	"					
23444	"	"					
23445	"	"					
23446	"	"					
23447	"	"					
23448	"	"					
23449	"	"	2)				
23450	"	"	2)				
23451	"	"	2)				
23452	"	"	2)				
23453	"	"	2)				
23454	"	"	2)				
23455	"	"	2)				
23456	"	"	2)				
23457	"	"	2)				
23458	"	"	2)				

1) Bremserhus som vist på tegn. 1849, er fjernet. 2) Platekledt varegulv. 3) Har skruebremse.

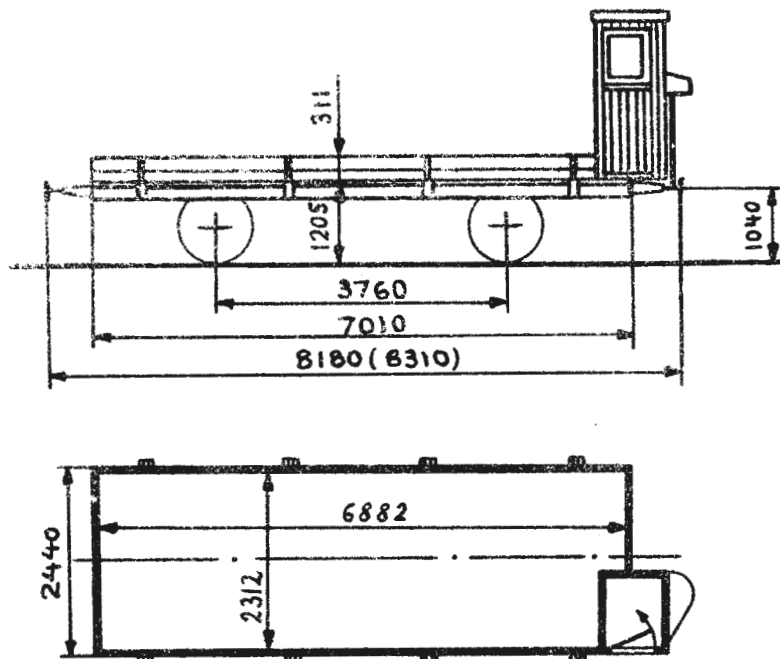

Bæreevne

A	B	C
12,0t	12,0t	

Omtrentlig vognvekt 5,5-6,0 t
 Gulvflate 15,1 m²
 Rominnhold 4,7 m³
 Hovedtegning Oslo distrikt 678

GRUSVOGN

Vogn nr.	Fabr.	Byggeår	Merknad	Vogn nr.	Fabr.	Byggeår	Merknad
2364	Oslo	04					
2367	Skb	"					
2369	"	"					
2377	Oslo	05					
2378	"	"					
2380	"	04					
2382	Skb	"					
2383	"	"					
2387	"	"					
2388	Oslo	05					
2390	"	"					
2391	"	"					
2397	"	04					
3816	Skb	1)					

1) Bygget för 1895.

Mf1

TYPE 2

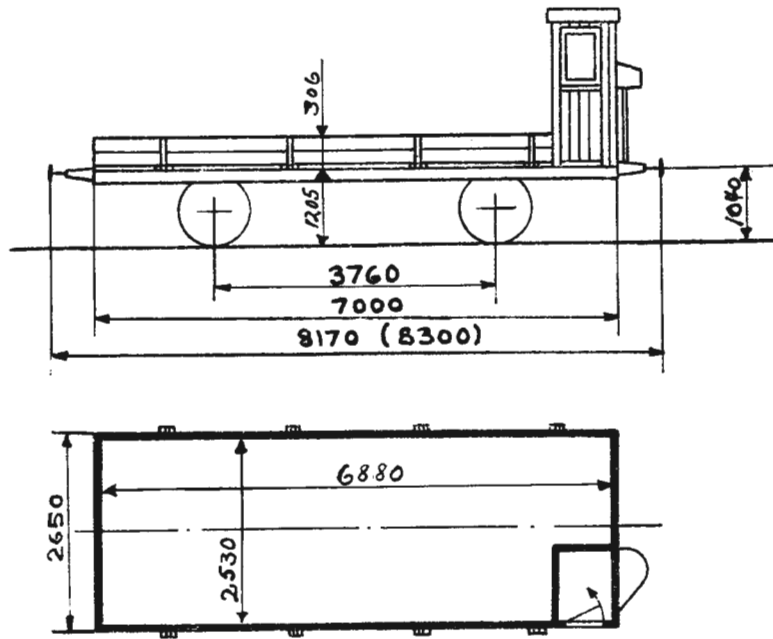

Bæreevne

A	B	C
12,0t	12,0t	

Omtrentlig vognvekt 6,0 t
 Gulvflate 10,5 m²
 Rominnhold 4,7 m³
 Hovedtegning 614 eller 1362

GRUSVOGN

Vogn nr.	Fabr.	Byggeår	Merknad	Vogn nr.	Fabr.	Byggeår	Merknad
			H-tegn. 1362	14449	Edf	06	
8283	Str	12					H-tegn. 1362
8285	"	"		20525	Edf	12	
8287	"	"		20526	"	"	
8288	"	"		20528	"	"	
8289	"	"		20529	"	"	
			H-tegn. 614	20530	"	"	
14416	Str	04					
14417	"	"					
14418	"	"					
14420	"	"					
14438	Skb	05					
14441	"	"					
14442	"	"					
14443	Edf	06					

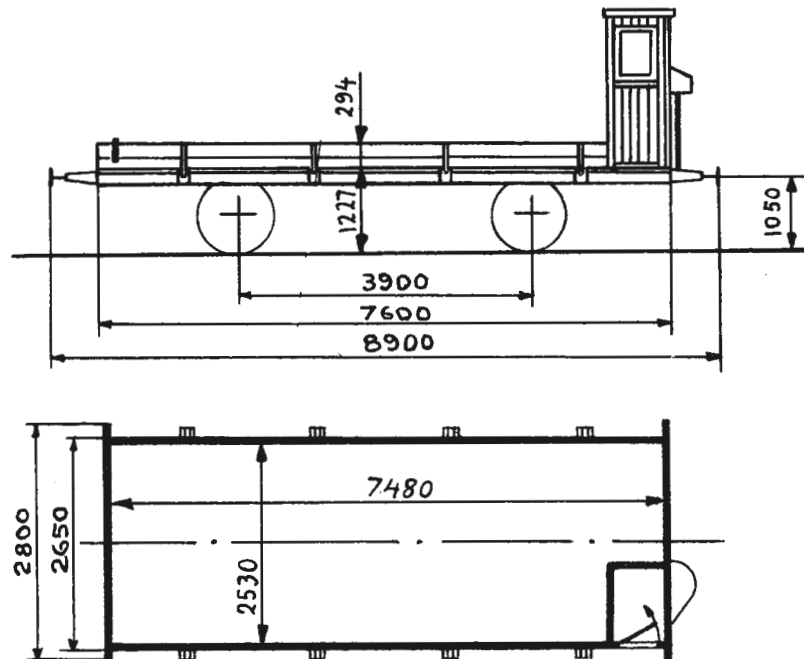

Bæreevne

A	B	C
11,0t	11,0t	

Omtrentlig vognvekt 7,0-11,0 t₂
 Gulvflate 18,3 m₂
 Rominnhold 4,8 m₃
 Hovedtegning 1334 + 1849

GRUSVOGN

Vogn nr.	Fabr.	Byggeår	Merknad	Vogn nr.	Fabr.	Byggeår	Merknad
5490	Skb	15		23470	Skb	15	
5491	"	"		23474	"	"	
5493	"	"	1)	23476	"	"	
5496	"	"	1)	23481	"	"	
5500	"	"	1)	23482	"	"	
17521	Str	"		23484	"	"	
17525	"	"		23489	"	"	
17526	"	"		23490	"	"	
17527	"	"		23495	"	"	
23459	Skb	"					
23462	"	"					
23464	"	"					
23467	"	"					
23468	"	"					
23469	"	"					

1) Platekledt varegulv.

Ms3

TYPE 1

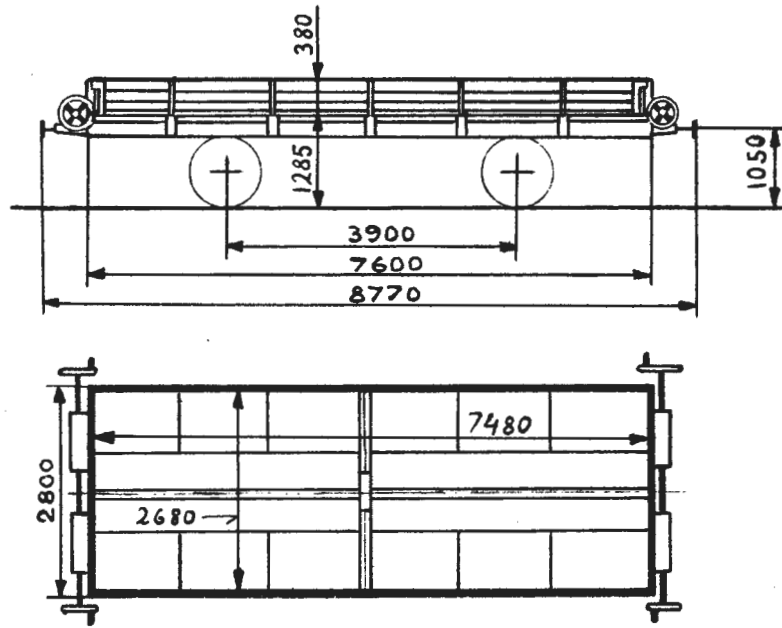

Omtrentlig vognvekt 8,5- 9,0 t
" last 14,0-14,5 t
Gulvflate 19,8 m²
Rominhold 7,6 m³
Hovedtegning 1350

SPESIAL GRUSVOGN

Vogn nr.	Fabr.	Byggeår	Merknad	Vogn nr.	Fabr.	Byggeår	Merknad
8222	Str	12					
8223	"	"					
8229	"	"					
8232	"	"					
8233	"	"	1)				
8235	"	"					
8237	"	"					

1) Har skrueremse.

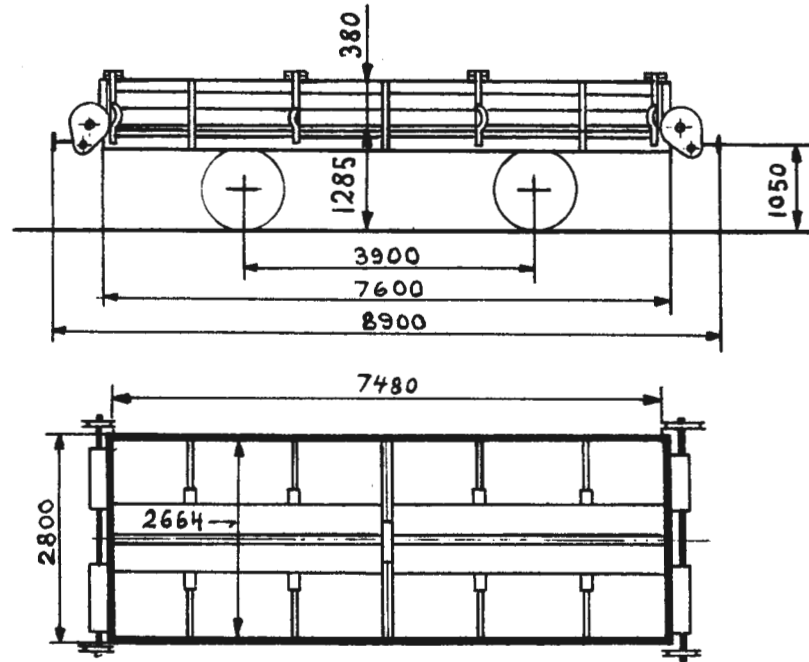

Omtrentlig vognvekt 9,0 t
 " last 14,0 t
 Gulvflate 19,3 m²
 Rominnhold 7,5 m³
 Hovedtegning 2253

SPESIAL GRUSVOGN

Vogn nr.	Fabr.	Byggeår	Merknad	Vogn nr.	Fabr.	Byggeår	Merknad
2126	Str	21		15872	Str	22	
2127	"	"		15873	"	"	
2128	"	"		15874	"	"	
2130	"	"		15875	"	"	
2131	"	"		15876	"	"	
2132	"	"		15877	"	"	
2133	"	"		15878	"	"	
2134	"	"		15879	"	"	
2135	"	"		15880	"	"	
6987	"	"		15881	"	"	
6989	"	"		15882	"	"	
6990	"	"		15883	"	"	
6993	"	"	1)	15884	"	"	
6994	"	"	1)	15885	"	"	
15871	"	22		15886	"	"	

1) Har skruerbremsse.

Ms3
TYPE 2

Vogn nr.	Fabr.	Byggear	Merknad	Vogn nr.	Fabr.	Byggear	Merknad
15887	Str	22					
15889	"	"					
15890	"	"					
15891	"	"					
15892	"	"					
15894	"	"	1)				
15898	"	"	1)				
15899	"	"	1)				

1) Har skruerbremsse.

Msf3

TYPE 2

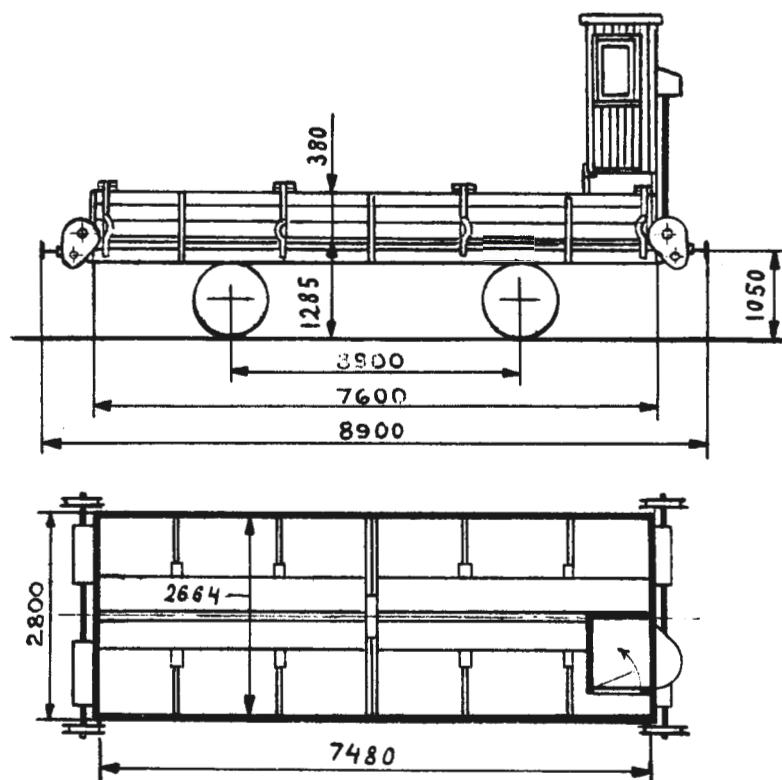

Omtrentlig vognvekt	9,5 t
" last	13,5 t
Gulvflate	19,3 m ²
Rominhold	7,5 m ³
Hovedtegning	2253 + 2449

SPESIAL GRUSVOGN

Vogn nr.	Fabr.	Byggeår	Merknad	Vogn nr.	Fabr.	Byggeår	Merknad
6995	Str	21					
15893	"	22					
15896	"	"					
15897	"	"					
15900	"	"					

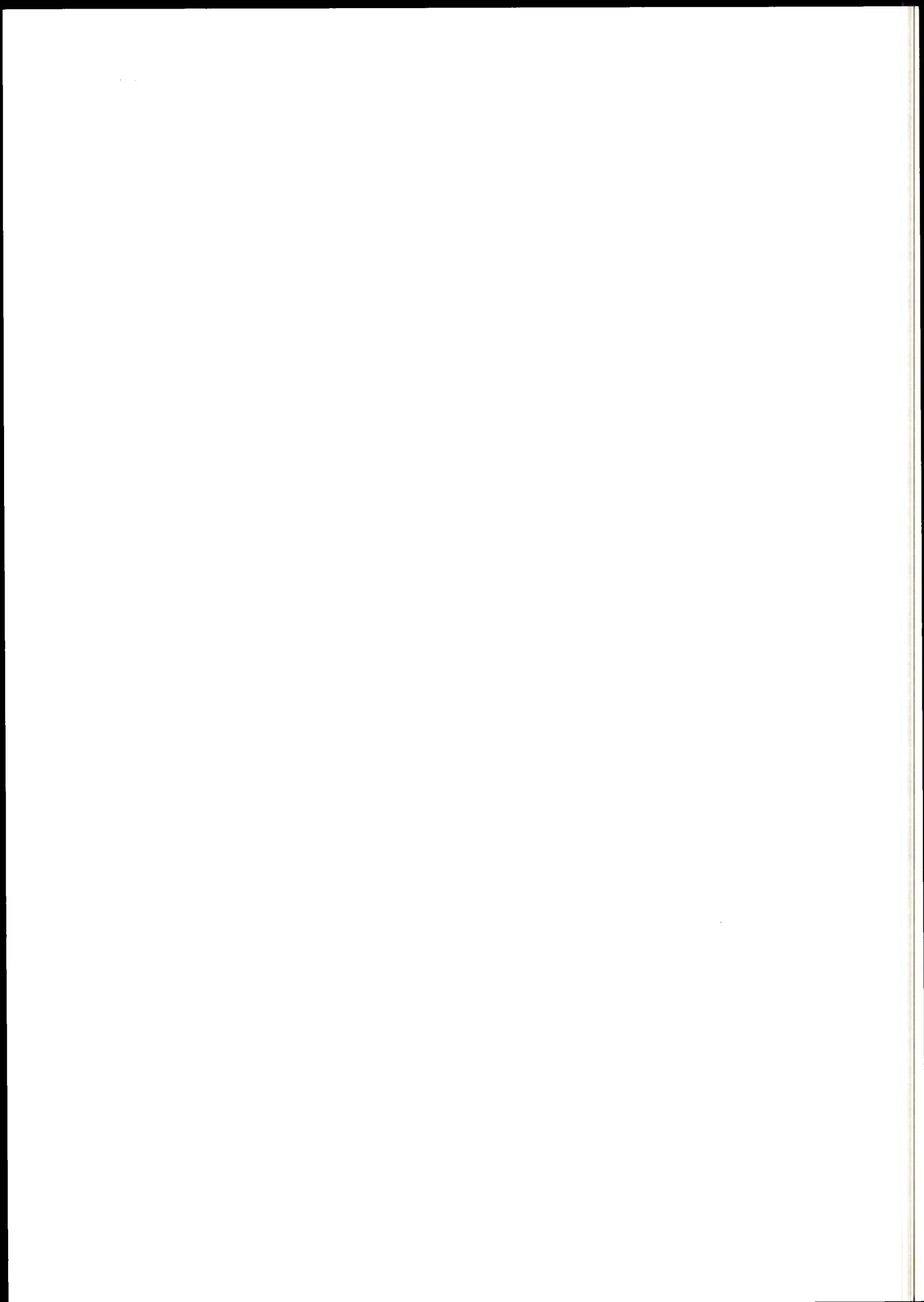

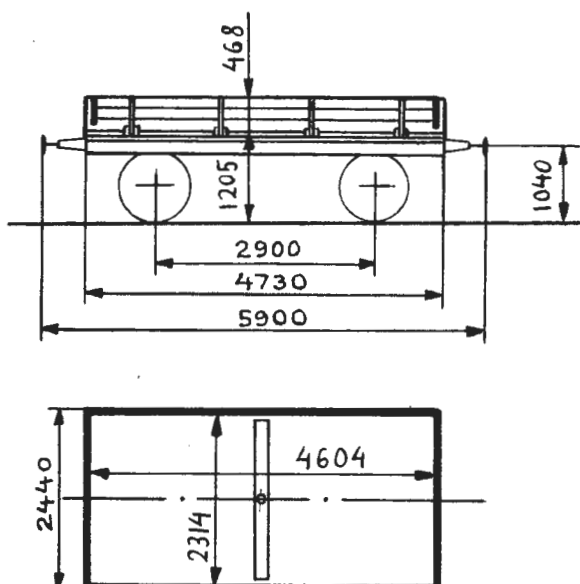

Omtrentlig vognvekt	5,5 t
" last	11,5 t
Gulvflate	10,6 m ²
Rominnhold	4,9 m ³
Hovedtegning	245

GRUS- OG TÖMMERVOGN

Vogn nr.	Fabr.	Byggeår	Merknad	Vogn nr.	Fabr.	Byggeår	Merknad
6150	Skb	02					
8212	Str	01					
12404	Wmr	"					

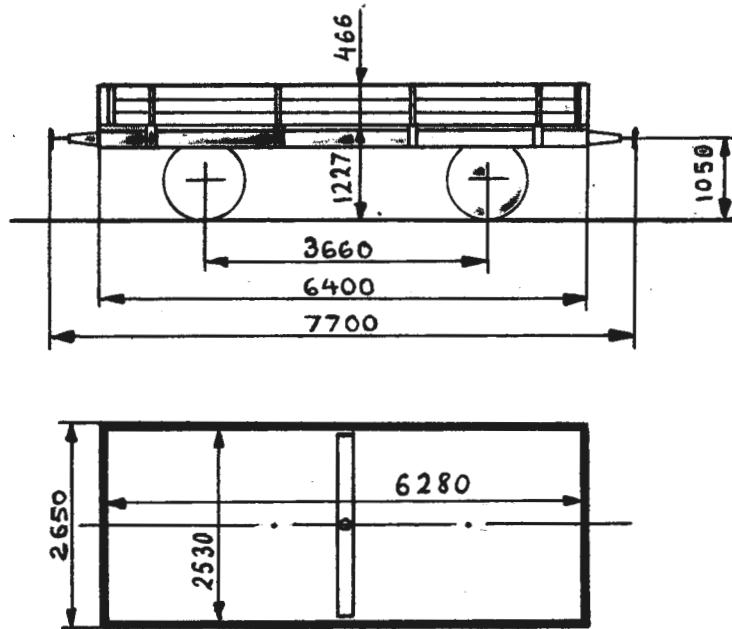

Omtrentlig vognvekt 7,0- 7,5 t
 " last 10,5 t₂
 Gulvflate 15,9 m²
 Rominnhold 7,4 m³
 Hovedtegning 2244

GRUS- OG TÖMMERVOGN

Vogn nr.	Fabr.	Byggeår	Merknad	Vogn nr.	Fabr.	Byggeår	Merknad
20231	AaB	23		20248	AaB	23	
20232	"	"		20249	"	"	
20233	"	"		20250	"	"	
20234	"	"					
20235	"	"					
20236	"	"					
20238	"	"					
20239	"	"					
20240	"	"					
20241	"	"					
20242	"	"					
20243	"	"					
20244	"	"					
20245	"	"					
20246	"	"					

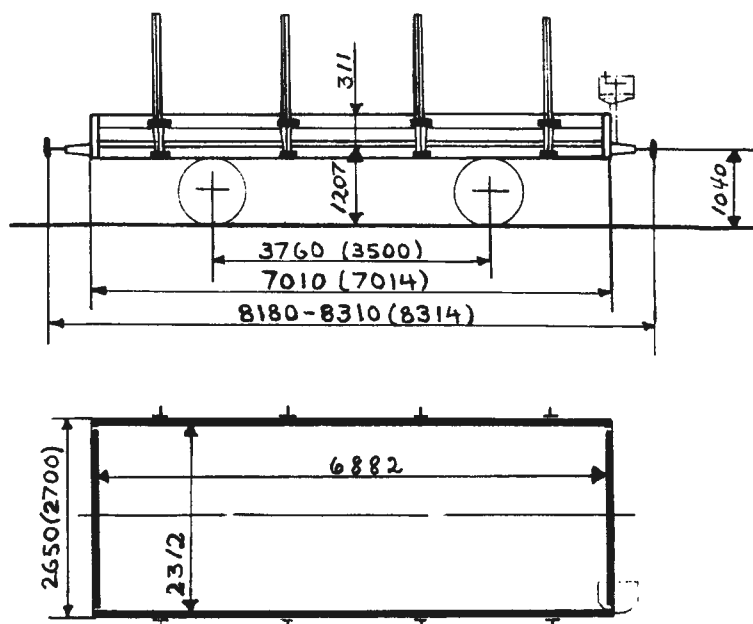

Omtrentlig vognvekt 6,0 t
 " last 10,5-11,0 t
 Gulvflate 17,4-17,7 m²
 Rominnhold 5,3 m³
 Hovedtegning 614 eller ukjent

STAKEVOGN

Vogn nr.	Fabr.	Byggeår	Merknad	Vogn nr.	Fabr.	Byggeår	Merknad
			H-tegn. ukjent	1923	Str	97	
1675	Str	83		1959	"	98	
1688	"	84		1963	"	"	
1698	"	"		1973	"	"	
1714	Skb	88		3955	Atl	76	
1739	Str	90		3958	"	"	
1742	"	"		3987	Oslo	15	
1757	"	"		4023	"	16	
1758	"	"		4094	"	15	
1851	"	78					H-tegn. 614
1860	"	"		10834	Str	01	
1878	"	"					H-tegn. ukjent
1879	"	"		11665	Str	99	
1905	"	95		11688	"	"	
1920	"	97					

N2

TYPE 1

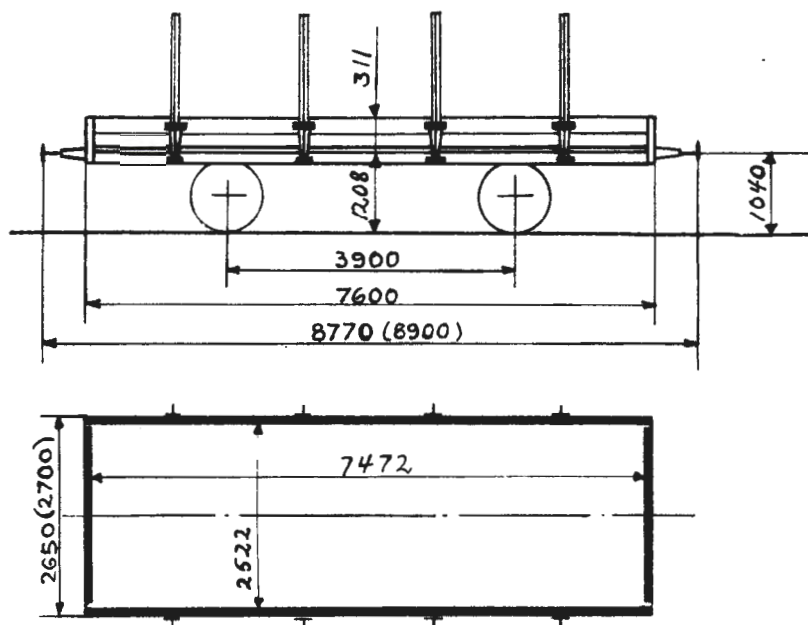

Omtrentlig vognvekt 5,5- 9,0 t
 " last 11,0 t
 Gulvflate 18,8-19,2 m²
 Rominnhold 5,6- 5,9 m³
 Hovedtegning 690, 815, B 183
 eller ukjent

STAKEVOGN

Vogn nr.	Fabr.	Byggeår	Merknad	Vogn nr.	Fabr.	Byggeår	Merknad
2402	Str	08	H-tegn. 815	4213	Str	08	H-tegn. 815
2403	"	"		5320	"	10	
2410	"	"		5324	"	"	
2514	Oslo	12	H-tegn. ukjent	6435	"	08	
2516	"	"		6440	"	"	
2524	"	13		6448	"	"	
				6450	"	"	
				7571	AaB	09	
2809	Str	03	H-tegn. 690	10851	Str	07	
4170	"	"		10856	"	"	
4172	"	"		10857	"	"	
4177	"	"		10868	"	"	
				10869	"	"	
				10871	"	"	

Vogn nr.	Fabr.	Byggear	Merknad	Vogn nr.	Fabr.	Byggear	Merknad
10872	Str	07					
10875	"	"					
10892	AaB	09					
10900	"	"					
10912	"	"					
			H-tegn. B 183				
11714	Str	07					
11720	"	"					
11722	"	"					
11738	AaB	08					
11750	"	"					
11759	"	"					
11765	Str	10					
11768	"	"					
11769	"	"					
11774	"	"					
11885	Skb	"					
11890	"	"					
11892	"	"					
11893	"	"					
11895	"	"					
11899	"	"					

N2

TYPE 2

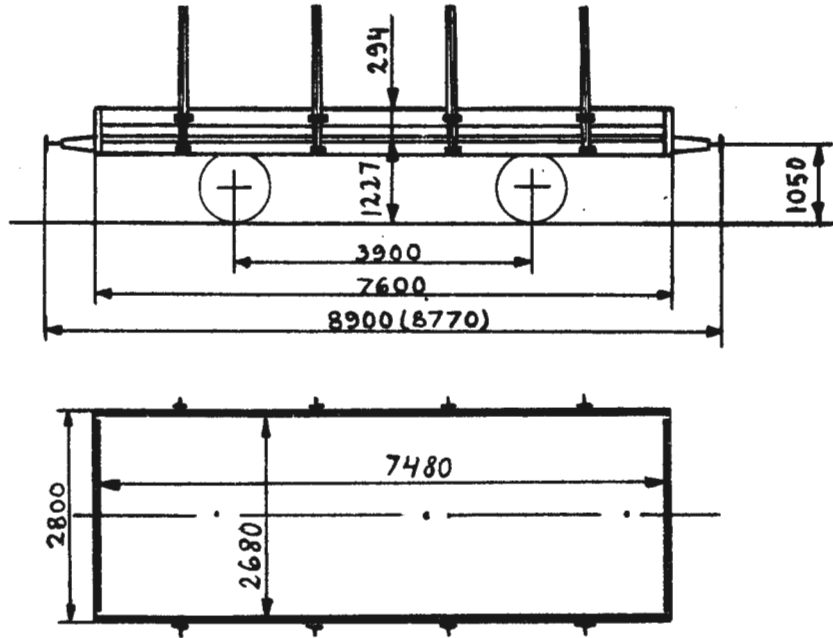

Bæreevne

A	B	C
11,5t	11,5t	

Omtrentlig vognvekt

6,0-6,5 t

Gulvflate

20,0 m²

Rominnhold

5,8 m³

Hovedtegning

1334

STAKEVOGN

Vogn nr.	Fabr.	Byggeår	Merknad	Vogn nr.	Fabr.	Byggeår	Merknad
3634	Edf	24		3823	Str	20	
3635	"	"		3824	"	"	
3636	"	"		3826	"	"	
3638	"	"		3827	"	"	
3639	"	"		3828	"	"	
3640	"	"		3829	"	"	
3641	"	"		3833	"	"	
3642	"	"		3834	"	"	
3644	"	"		3835	"	"	
3647	"	"		3836	"	"	
3649	"	"		3837	"	"	
3652	"	"		3838	"	"	
3653	"	"		3839	"	"	
3657	"	"		3840	"	"	
3822	Str	20		3841	AaB	23	

Vogn nr.	Fabr.	Byggeår	Merknad	Vogn nr.	Fabr.	Byggeår	Merknad
3843	AaB	23		5325	HJ	12	
3844	"	"		5327	"	"	
3846	"	"		5328	"	"	
3847	"	"		5330	AaB	14	
3850	"	"		5331	"	"	
3891	"	"		5334	"	"	
3894	"	"		5335	"	"	
3897	"	"		5338	"	"	
3899	"	"		5339	"	"	
3902	Atl	76	1)	5340	"	"	
3904	"	"	1)	5341	"	"	
3908	Oslo	25		5343	"	"	
3910	"	"		5344	"	"	
3911	"	"		5345	"	"	
3918	"	"		5346	"	"	
3999	Atl	76	1)	5347	"	"	
4027	Oslo	25		5348	"	"	
4036	"	"		5349	Str	20	
4037	"	"		5350	"	"	
4040	"	"		5352	"	"	
4079	Atl	76	1)	5353	"	"	
4119	Skb	24		5355	"	"	
4120	"	"		5356	"	"	
4122	"	"		5357	"	"	
4123	"	"		5358	"	"	
4124	"	"		5361	"	"	
4125	"	"		5364	"	"	
4126	"	"		5365	"	"	
4127	"	"		5366	"	"	
4129	"	"		5367	"	"	
4130	"	"		5368	"	"	
4131	"	"		5601	AaB	13	
4132	"	"		5603	"	"	
4133	"	"		5604	"	"	
4194	Atl	76	2) 3)	5605	"	"	

1) H-tegn. ukjent. 2) H-tegn. 815. 3) Tank for melktransport.

N2
TYPE 2

Vogn nr.	Fabr.	Byggeår	Merknad	Vogn nr.	Fabr.	Byggeår	Merknad
5606	AaB	13		6489	Str	12	
5607	"	"		6490	"	"	
5608	"	"		6493	"	"	
5609	"	"		6496	"	"	
5610	"	"		6497	"	"	
5611	"	"		6498	"	"	
5613	"	"		6501	"	"	
5615	"	"		6507	"	"	
5616	"	"		6508	"	"	
5617	"	"		6509	"	"	
5618	"	"		6510	"	"	
5619	"	"		6511	"	"	
5719	Skb	23		6514	"	"	
5721	"	"		6516	"	"	
5724	"	"		6520	"	"	
5726	"	24		6522	"	"	
5728	"	"		6525	"	"	
5733	"	"		6526	"	"	
5738	"	"		6528	"	"	
5739	"	"		6529	"	"	
5743	"	"		6531	"	"	
5744	"	"		6532	"	"	
5750	"	"		6535	"	"	
6461	HJ	12		6663	Skb	16	
6466	"	"		6667	"	"	
6469	"	"		6670	"	"	
6470	"	"		6671	"	"	
6471	"	"		6676	"	"	
6472	"	"		6679	"	"	
6474	"	"		6681	"	"	
6477	Str	"		6682	"	"	
6479	"	"		6683	"	"	
6480	"	"		6685	"	"	
6486	"	"		6686	"	"	
6488	"	"		6687	"	"	

Vogn nr.	Fabr.	Byggeår	Merknad	Vogn nr.	Fabr.	Byggeår	Merknad
6688	Skb	16		8675	Skb	24	
6689	"	"		8678	"	"	
6690	"	"		8680	"	"	
6691	"	"		9537	"	16	
6693	"	"		9538	"	"	
6694	"	"		9544	"	"	
6696	"	"		9545	"	"	
6698	"	"		9546	"	"	
6700	"	"		9548	"	"	
6955	Str	20		9549	"	"	
6956	"	"		9551	"	"	
6958	"	"		9552	"	"	
6960	"	"		9556	"	"	
6961	"	"		9558	"	"	
6962	"	"		9559	"	"	
6963	"	"		9561	"	"	
6964	"	"		9562	"	"	
6966	"	"		9563	"	"	
6968	"	"		9566	"	"	
6970	"	"		9568	Str	17	
8626	Skb	23		9569	"	"	
8627	"	"		9572	"	"	
8628	"	"		9575	"	"	
8629	"	"		9576	"	"	
8630	"	"		9578	"	"	
8635	"	"		9579	"	"	
8636	"	"		9582	"	"	
8638	"	"		9583	"	"	
8639	"	"		9585	"	"	
8640	"	"		9587	"	"	
8643	"	"		9589	"	"	
8646	"	"		9595	"	"	
8648	"	"		9596	"	"	
8649	"	"		9598	"	"	
8674	"	24		9600	"	"	

N2
TYPE 2

Vogn nr.	Fabr.	Byggeår	Merknad	Vogn nr.	Fabr.	Byggeår	Merknad
9601	Str	17		16369	Str	20	
9602	"	"		16371	"	"	
9604	"	"		16372	"	"	
9605	"	"		16373	"	"	
9609	"	"		16377	"	"	
9610	"	"		16378	"	"	
9613	"	"		16380	"	"	
9615	"	"		16381	"	"	
9616	"	"		16383	"	"	
9618	"	"		16384	"	"	
9619	"	"		16385	AaB	23	
9620	"	"		16386	"	"	
9621	"	"		16387	"	"	
9622	"	"		16389	"	"	
9623	"	"		16390	"	"	
9625	"	"		16391	"	"	
14470	HJ	14		16392	"	"	
14471	"	"		16395	"	"	
14472	"	"		16396	"	"	
14473	"	"		16397	"	"	
14475	"	"		16401	"	"	
14476	"	"		16404	"	"	
14481	"	"		16405	"	"	
14482	"	"		16407	"	"	
14483	"	"		16408	"	"	
14486	"	"		16409	"	"	
14487	"	"		16410	"	"	
14488	"	"		16413	"	"	
14490	"	"		16415	Edf	24	
14491	"	"		16416	"	"	
14494	"	"		16417	"	"	
14498	"	"		16418	"	"	
16365	Str	20		16420	"	"	
16366	"	"		16422	"	"	
16368	"	"		16424	"	"	

Vogn nr.	Fabr.	Byggeår	Merknad	Vogn nr.	Fabr.	Byggeår	Merknad
16426	Edf	24		20109	AaB	21	
16427	"	"		20110	"	"	
16429	"	"		20111	"	"	
16432	"	"		20112	"	"	
16434	"	"		20113	"	"	
16436	"	"		20114	"	"	
16437	"	"		20115	"	"	
16438	"	"		20116	"	"	
16441	"	"		20117	"	"	
16442	"	"		20118	"	"	
16443	"	"		20119	"	"	
16465	Skb	"		20120	"	"	
16466	"	"		20121	"	"	
16467	"	"		20122	"	"	
16468	"	"		20123	"	"	
16469	"	"		20124	"	"	
16470	"	"		20125	"	"	
16471	"	"		20126	"	22	
16472	"	"		20127	"	"	
16473	"	"		20128	"	"	
16474	"	"		20131	"	"	
16555	Str	20		20132	"	"	
16556	"	"		20133	"	"	
16557	"	"		20134	"	"	
16558	"	"		20136	"	"	
16560	"	"		20138	"	"	
16561	"	"		20139	"	"	
16562	"	"		20140	"	"	
16563	"	"		20141	"	"	
20101	AaB	21		20142	"	"	
20103	"	"		20143	"	"	
20105	"	"		20145	"	"	
20106	"	"		20146	"	"	
20107	"	"		20147	"	"	
20108	"	"		20149	"	"	

N2
TYPE 2

Vogn nr.	Fabr.	Byggeår	Merknad	Vogn nr.	Fabr.	Byggeår	Merknad
20150	AaB	22		20712	AaB	13	
20201	"	"		20713	"	"	
20202	"	"		20715	"	"	
20203	"	"		20716	"	"	
20204	"	"		20721	"	"	
20205	"	"		20722	"	"	
20207	"	"		20723	"	"	
20208	"	"		20725	"	"	
20209	"	"		20726	"	"	
20210	"	"		20727	"	"	
20211	"	"		20730	"	"	
20212	"	"		20731	"	"	
20213	"	"		20733	"	"	
20214	"	"		20734	"	"	
20215	"	"		20735	"	"	
20216	"	"		20739	"	"	
20217	"	"		20740	"	"	
20218	"	"		23001	"	14	
20219	"	"		23003	"	"	
20220	"	"		23005	"	"	
20221	"	"		23006	"	"	
20222	"	"					
20223	"	"					
20226	"	"					
20227	"	"					
20229	"	"					
20230	"	"					
20702	"	13					
20703	"	"					
20704	"	"					
20706	"	"					
20707	"	"					
20709	"	"					
20710	"	"					
20711	"	"					

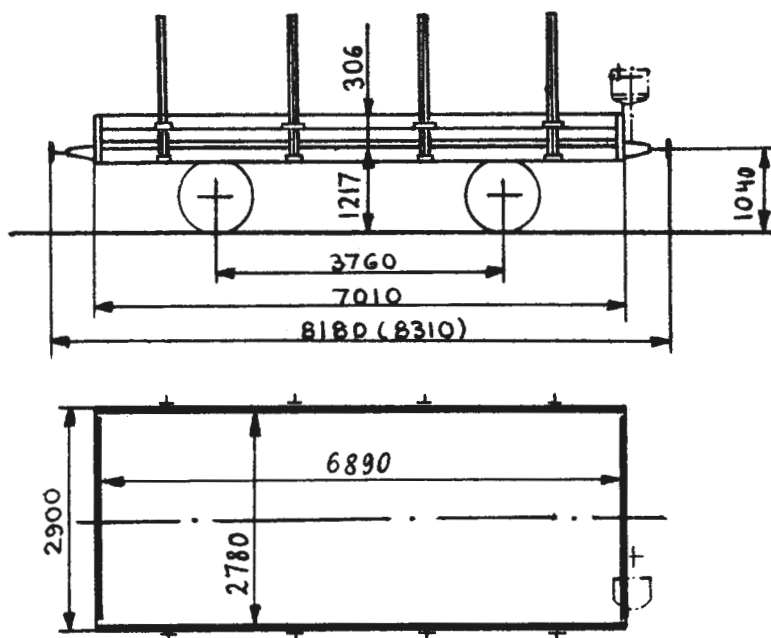

Bæreevne

A	B	C
11,5t	11,5t	

Omtrentlig vognvekt 6,0-6,5 t
 Gulvflate 19,1 m²
 Rominnhold 5,8 m³
 Hovedtegning 3070 1)

STAKEVOGN

Vogn nr.	Fabr.	Byggeår	Merknad	Vogn nr.	Fabr.	Byggeår	Merknad
2441	Str	99		3985	Atl	77	
2579	Skb	89		4000	Oslo	13	
2604	Str	91		4001	"	14	
2606	"	"		4005	"	19	
2629	"	97		4022	"	14	
2639	"	"		4031	Atl	16	
2676	"	98		5279	Str	00	
2678	"	"		5292	"	"	
2866	Skb	00		5296	"	"	
3907	Oslo	15		5303	"	"	
3909	"	16		6327	"	97	
3919	"	"		6390	Skb	00	
3937	"	14		7507	Str	92	
3950	"	16		7525	"	"	
3962	Atl	76		7531	"	"	

1) Vogner med litra N2-3 er vogner med tidl. litra N1-1 som er ombygd etter tegn. 3070.

Vogn nr.	Fabr.	Byggear	Merknad	Vogn nr.	Fabr.	Byggear	Merknad
8504	Str	92		16213	Edf	01	
8528	Ldv	"		16228	"	"	
8530	"	"		16231	"	"	2)
8574	Str	97		16232	"	"	
8601	"	99		16259	"	"	
8656	HJ	14		16263	"	06	
8657	"	"		16266	"	"	
8659	"	"		16294	"	"	
8668	"	"		16306	Skb	08	
8669	"	"		16308	"	"	
8670	"	"		16310	"	"	
9511	Edf	00		16445	AaB	12	
9516	Skb	"		16460	"	"	
9524	"	"		16462	"	"	
10804	"	"					
10811	"	"					
10814	"	"					
10823	"	"					
10838	Str	01					
10999	AaB	12					
12502	Str	00					
12503	"	"					
12509	"	"					
12520	"	"					
12521	"	"					
12535	"	"					
16076	"	99					
16092	KvB	93					
16106	Edf	00					
16140	"	"					
16165	"	"					
16175	"	"					
16190	"	01					
16195	"	"					
16210	"	"					

2) Påmontert melktank for Drm. meieri.

No2

TYPE 1

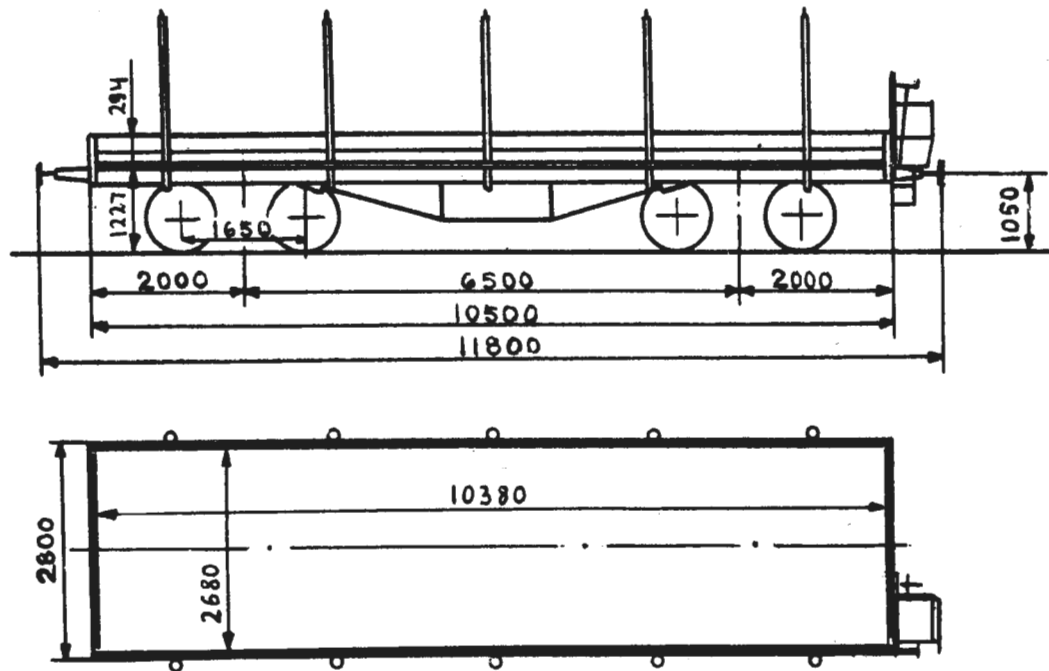

Omtrentlig vognvekt	11,5-12,5	t
" last	21,5	t
Gulvflate	26,9	m ²
Rominnhold	7,9	m ³
Hovedtegning	2171	1)

STAKEVOGN

Vogn nr.	Fabr.	Byggeår	Merknad	Vogn nr.	Fabr.	Byggeår	Merknad
6847	Skb	16					
10936	Str	22					
10937	"	"					

1) Bremsarhuset er fjernet og erstattet med bremsplattform etter tegn. 3788.

NP2

TYPE 1

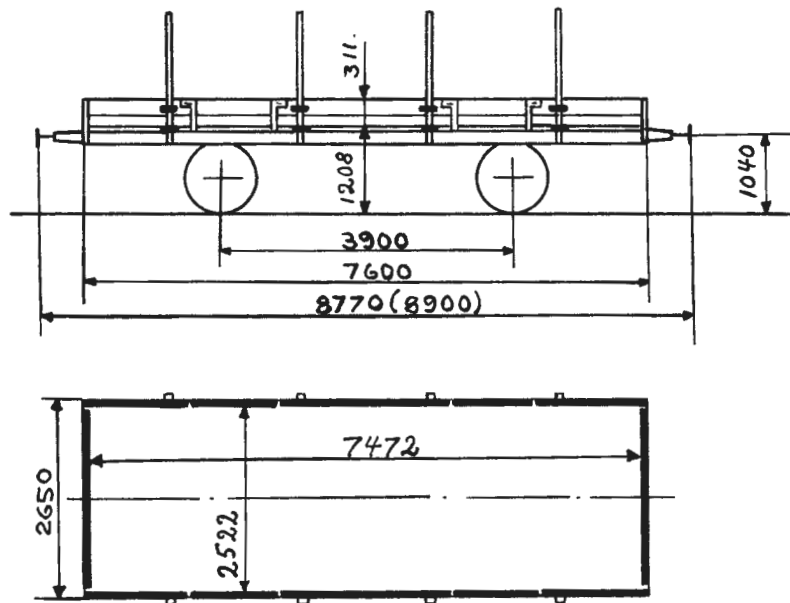

Omtrentlig vognvekt 6,0-7,0 t
 " last 11,0 t
 Gulvflate 18,9 m²
 Rominnhold 5,9 m³
 Hovedtegning 815+897 eller
 815+897+4363

STAKE- OG MALMVOGN

Vogn nr.	Fabr.	Byggeår	Merknad	Vogn nr.	Fabr.	Byggeår	Merknad
5309	Str	09	H-tegn. 815+897	16344	AaB	09	
5310	"	"		16347	Str	"	
5317	"	"		16359	"	"	
10506	"	08		16361	"	"	
10517	"	05		16363	"	"	
10524	"	"					
16313	AaB	09		H-tegn. 815+897+ 4363			
16317	"	"					
16323	"	"					
16324	"	"					
16326	"	"					
16334	"	"					

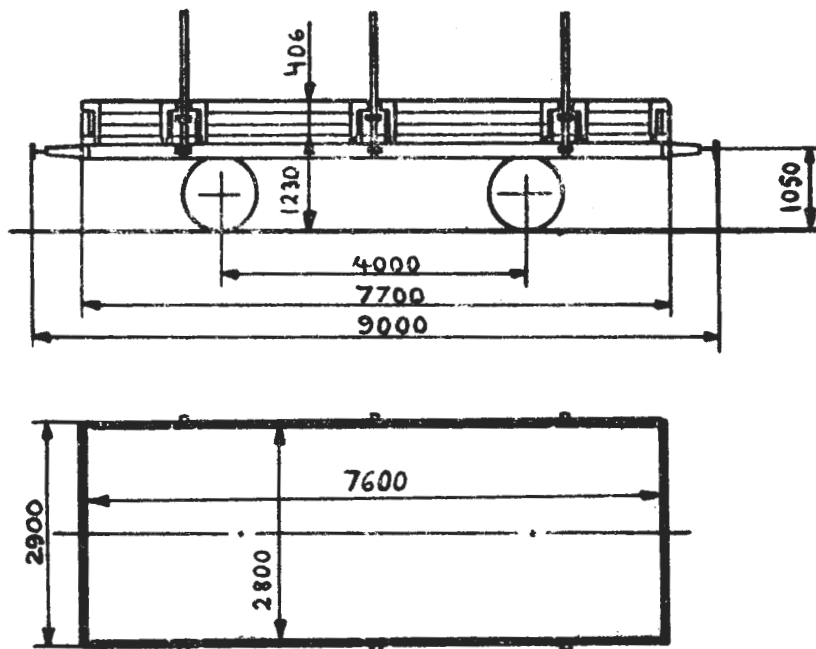

Omtrentlig vognvekt 8,0 t
 " last 15,0 t
 Gulvflate 21,2 m²
 Rominnhold 8,6 m³
 Hovedtegning 1268

STAKE- OG MALMVOGN

Vogn nr.	Fabr.	Byggeår	Merknad	Vogn nr.	Fabr.	Byggeår	Merknad
13054	Edf	11		13072	Edf	15	
13055	"	"		13073	"	"	
13056	"	"		13086	AaB	23	
13057	"	"		13087	"	"	
13059	"	"		13088	"	"	
13060	"	"		13089	"	"	
13061	"	"		13090	"	"	
13063	"	"		13091	"	"	
13064	"	15		13092	"	"	
13065	"	"		13093	"	"	
13066	"	"		13094	"	"	
13067	"	"		13095	"	"	
13068	"	"					
13069	"	"					
13071	"	"					

Vogner med litra NP3-1 har nedleggbare lemmer.

NPo3

TYPE 1

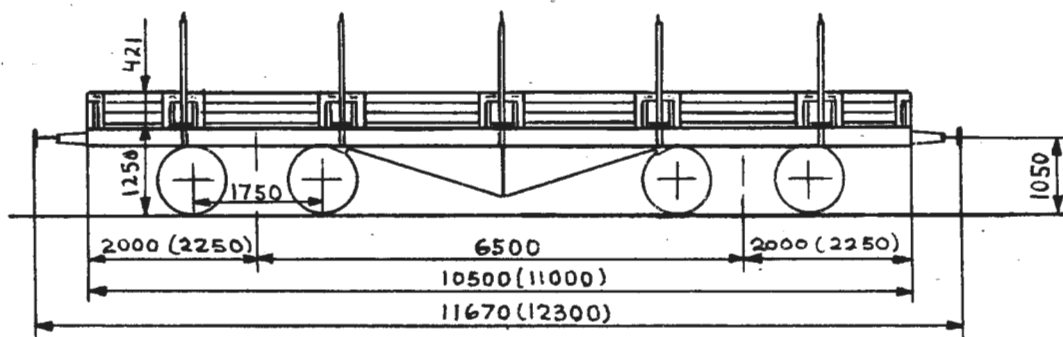

Måli () for vogner
nr. 13080, 13081.

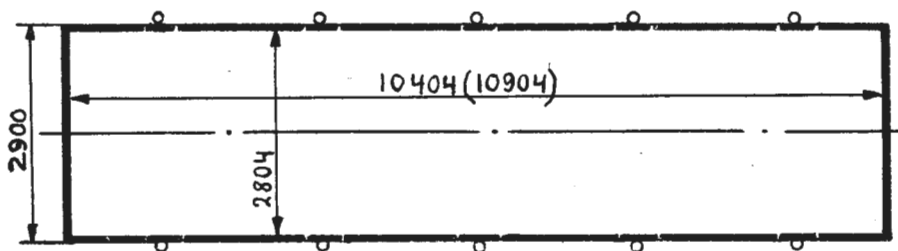

Omtrentlig vognvekt 14,0-15,0 t
" last 31,0-32,0 t
Gulvflate 29,1-30,6 m²
Rominnhold 12,2-12,8 m³
Hovedtegning 917

STAKE- OG MALMVOGN

Vogn nr.	Fabr.	Byggeår	Merknad	Vogn nr.	Fabr.	Byggeår	Merknad
13042	Edf	09	2)				
13043	"	"					
13080	Skb	21	1) 3)				
13081	"	"	1)				

1) Forøket lengde. 2) Vognvekt 15670 kg, inklusive 1 kran. 3) Vognvekt 16180 kg, inklusive 1 kran.

Trykk nr. 752 1.1.61

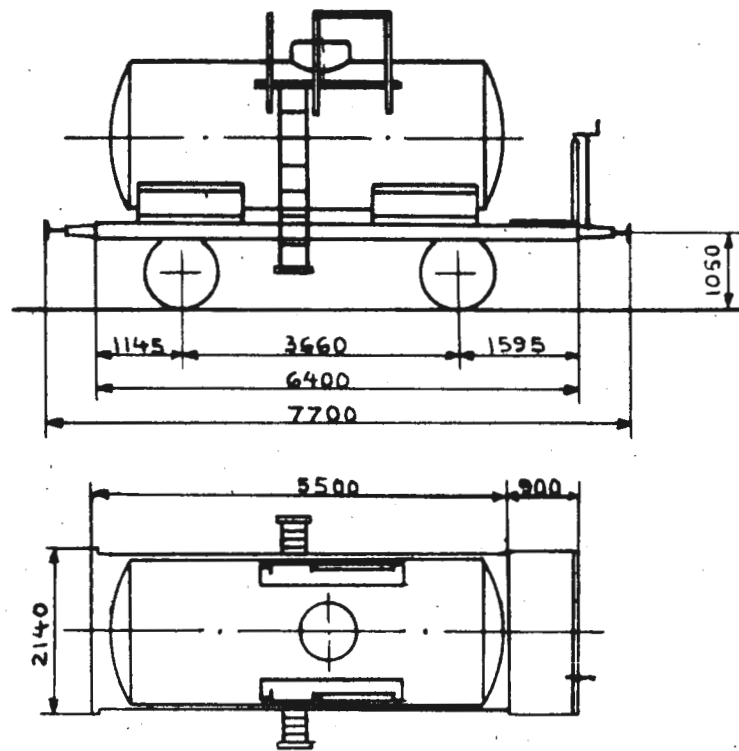

Omtrentlig vognvekt 9,0-10,5 t
 " last 13,5 t
 Rominnhold 13,8 m³
 Hovedtegning 2658 1)

TANKVOGN (FOR KREOSOTOLJE)

Vogn nr.	Fabr.	Byggeår	Merknad	Vogn nr.	Fabr.	Byggeår	Merknad
4956	Str	26					
4957	"	"					
4958	"	"					
4986	"	40					
4987	"	"					
4988	"	"					

1) Bremserhuset er fjernet.

Q3
TYPE 3

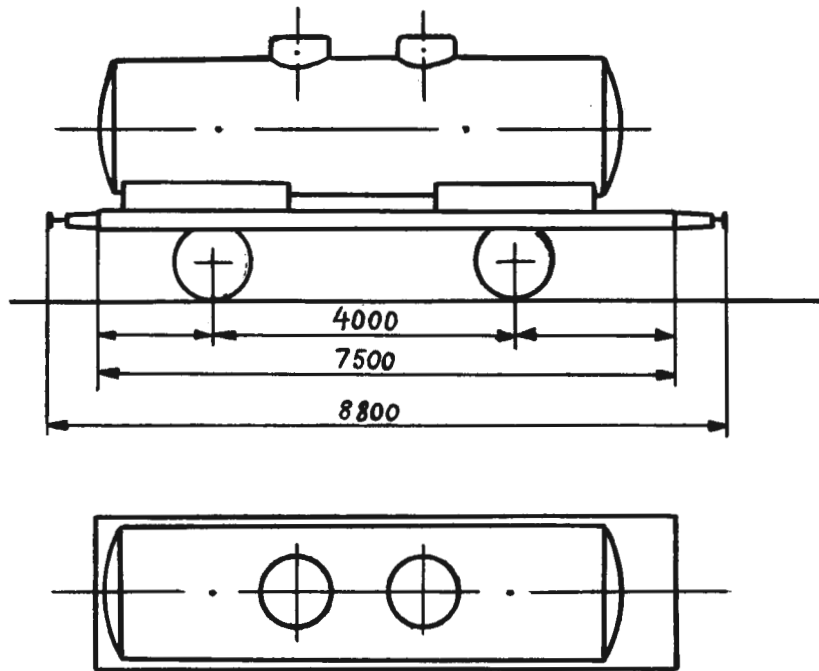

Omtrentlig vognvekt 10,7 t
 " last 12,5 t
 Gulvflate --
 Rominnhold 15,0 m³
 Hovedtegning --

TANKVOGN

Vogn nr.	Fabr.	Byggeår	Merknad	Vogn nr.	Fabr.	Byggeår	Merknad
11301	Z+C	14					
11302	"	"					

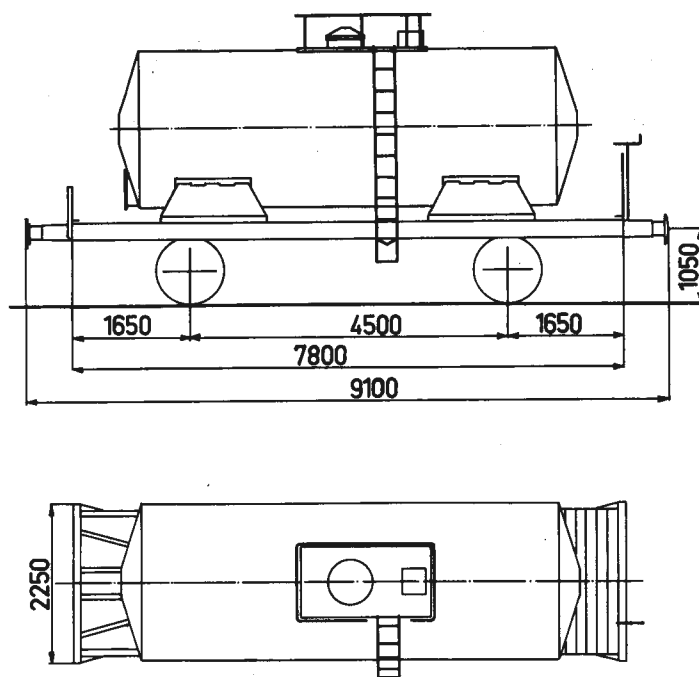

Bæreevne

A	B	C
18,0t		18,0t

Omtrentlig vognvekt 11,0-12,5t

Gulvflate -

Rominhold 22,0 m³

Hovedtegning 8271 1)

TANKVOGN

Vogn nr.	Fabr.	Byggeår	Merknad	Vogn nr.	Fabr.	Byggeår	Merknad
73013	2)	20		73027	LH	13	
73014	WLS	"					
73015	AGM	19					
73016	MAN	18					
73017	ME	12					
73018	GHw	15					
73019	GL	19					
73020	BAE	01					
73021	O&K	22	3)				
73022	AG	21					
73023	LH	15					
73024	2)	20					
73025	LH	18					
73026	AfE	16					

3) Bæreevne A: 19,5 t , BC: 23,5 t.

1) Omb. fra tidl. tyske G-vogner, år 1958. 2) Vognfabrikant ukjent.
Trykk nr. 752 1.1.68

Q 4
TYPE 4

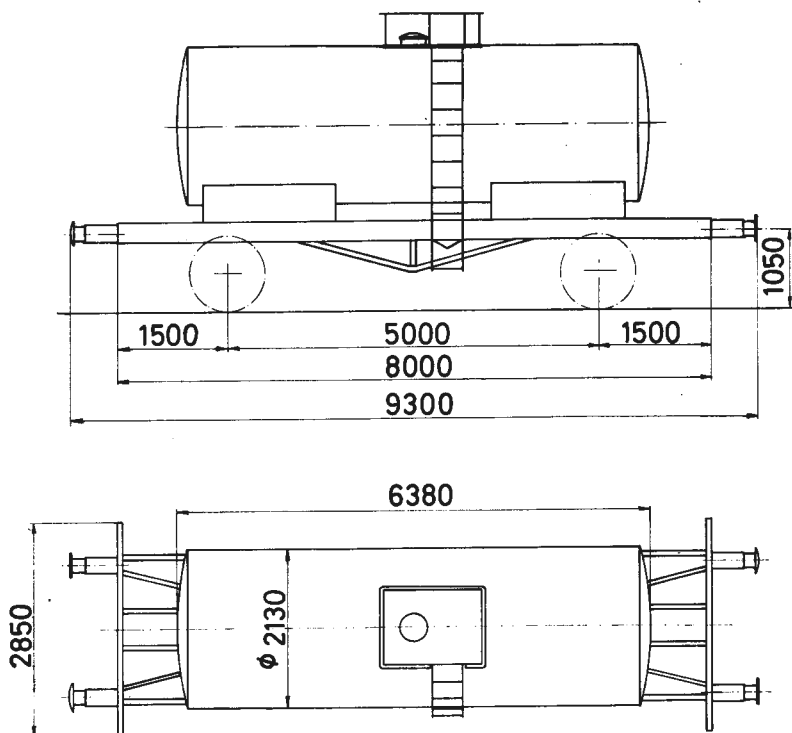

Bæreevne

A	B	C
18,5t	18,5t	

Omtrentlig vognvekt 11,5 t
 Rominnhold 21,3 m³
 Hovedtegning 1)

TANKVOGN

Vogn nr.	Fabr.	Byggeår	Merknad	Vogn nr.	Fabr.	Byggeår	Merknad
50157	Edf	46					

1) Oppr. hovedtegn. 3989. Tank mont. på understilling fra L4 type 3.

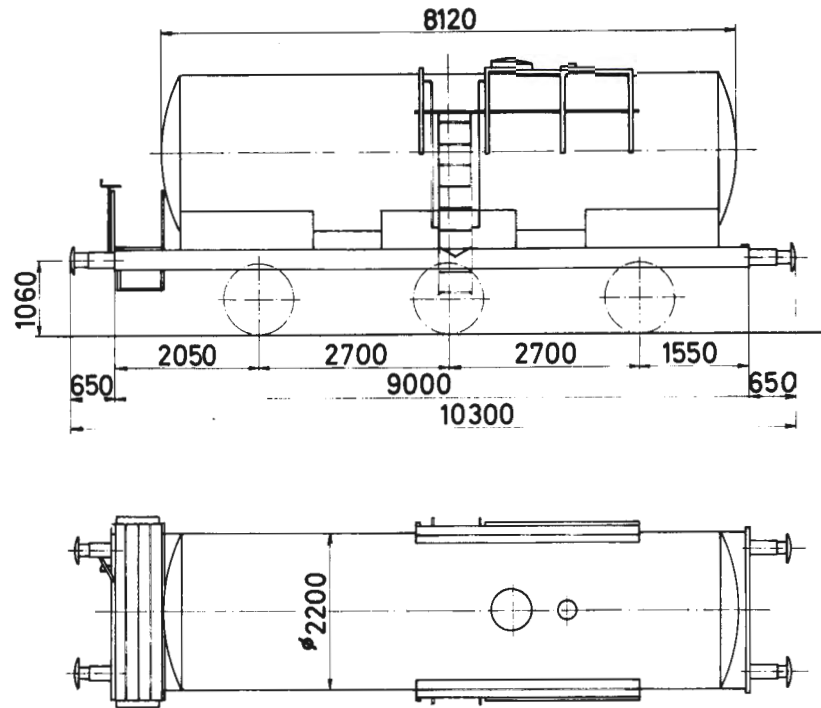

Bæreevne

A	B	C
28,0t	28,0t	

Omtrentlig vognvekt 16,0t
 Rominnhold 30,0 m³
 Hovedtegning 8/32

TANKVOGN

Vogn nr.	Fabr.	Byggeår	Merknad	Vogn nr.	Fabr.	Byggeår	Merknad
73029	WM	38					

Qo2
TYPE 1

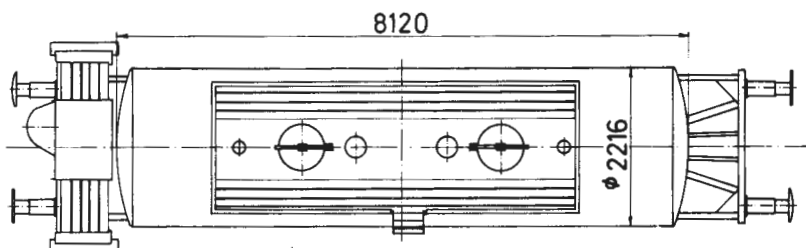
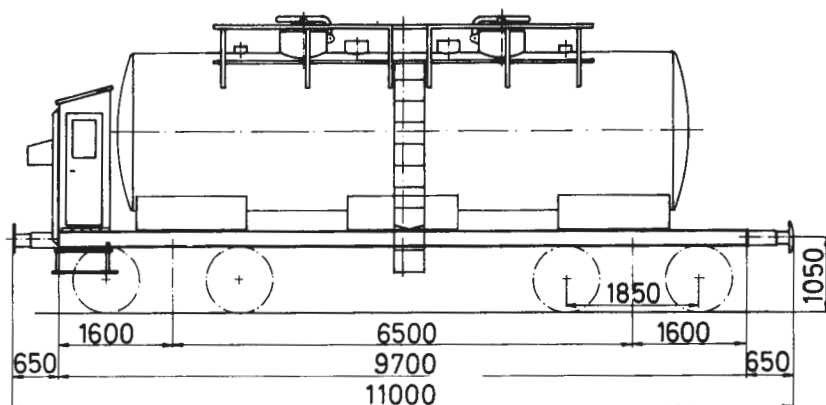

Omtrentlig vognvekt 16,0 - 17,0t
 Bæreevne 20,0 - 21,0t
 Rominnhold 30,0 m³
 Hovedtegning Skabo Q 26

TANKVOGN

Vogn nr.	Fabr.	Byggeår	Merknad	Vogn nr.	Fabr.	Byggeår	Merknad
73030	Skb	40					
73031	"	"					

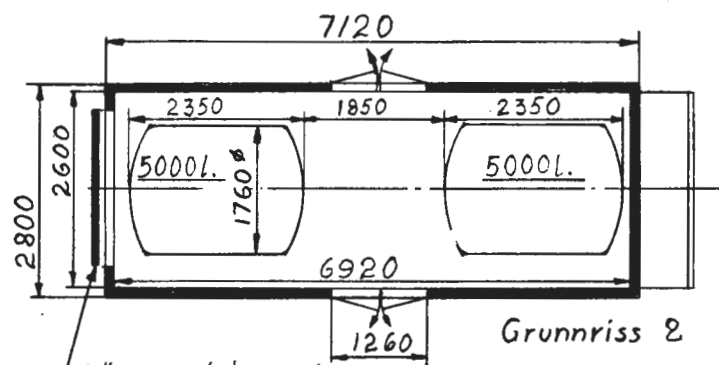
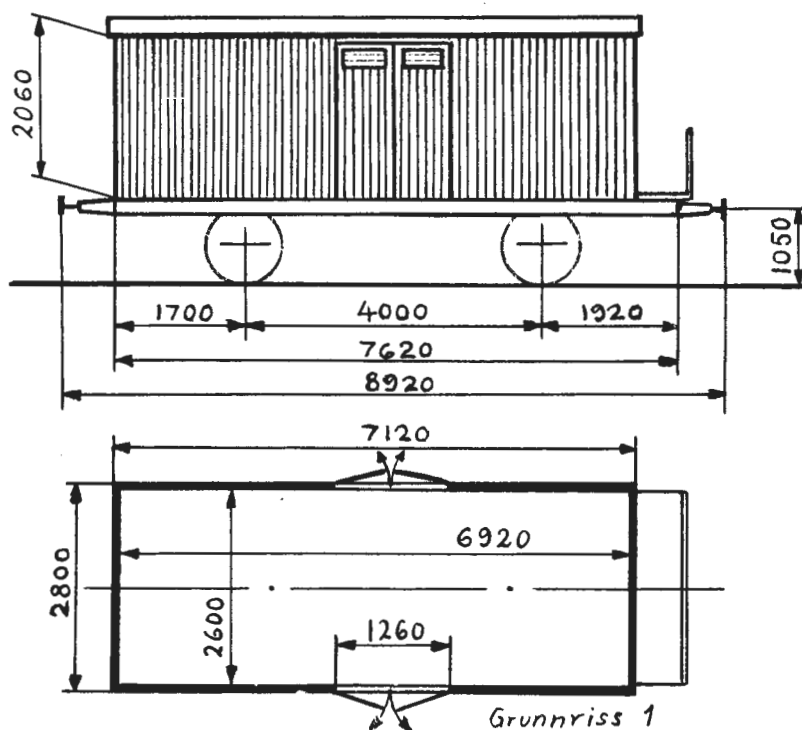

Lös endelem for
montering av tanker

Omtrentlig vognvekt 10,5-12,5 t
 " bæreevne 11,5-13,0 t
 Gulvflate 18,0 m²
 Rominnhold 36,7 m³
 Hovedtegning 2275 1)

MELKVOGN

Vogn nr.	Fabr.	Byggeår	Merknad	Vogn nr.	Fabr.	Byggeår	Merknad
2900	NVV	21	2)	4521	Edf	21	2)
2901	"	"	3)	4523	"	"	2)
4517	Edf	"	2)	4524	"	"	2)
4518	"	"	2)	4525	"	"	2)
4519	"	"	2)	4528	"	"	2)
4520	"	"	2)	4529	"	"	2)
				4530	"	"	2)

1) Med forandring etter skisse nr. 233. 2) Grunnriss 1. 3) Grunnriss 2.

Vogn nr.	Fabr.	Byggeår	Merknad	Vogn nr.	Fabr.	Byggeår	Merknad
4533	Edf	21	2)				
4534	"	"	2)				
6979	NVV	"	2)				
6980	"	"	2)				
6982	"	"	2)				
6983	"	"	2)				
6984	"	"	2)				
6986	"	"	2)				
8371	"	"	2)				
8372	"	"	2)				
8373	"	"	2)				
8374	"	"	2)				
8376	"	"	2)				
20251	Edf	22	2)				
20253	"	"	2)				
20255	"	"	2)				
20256	"	"	2)				
20257	"	"	2)				
20258	"	"	2)				
20769	NVV	21	2)				
20770	"	"	2)				
20771	"	"	2)				
20772	"	"	2)				

2) Grunnriss 1.

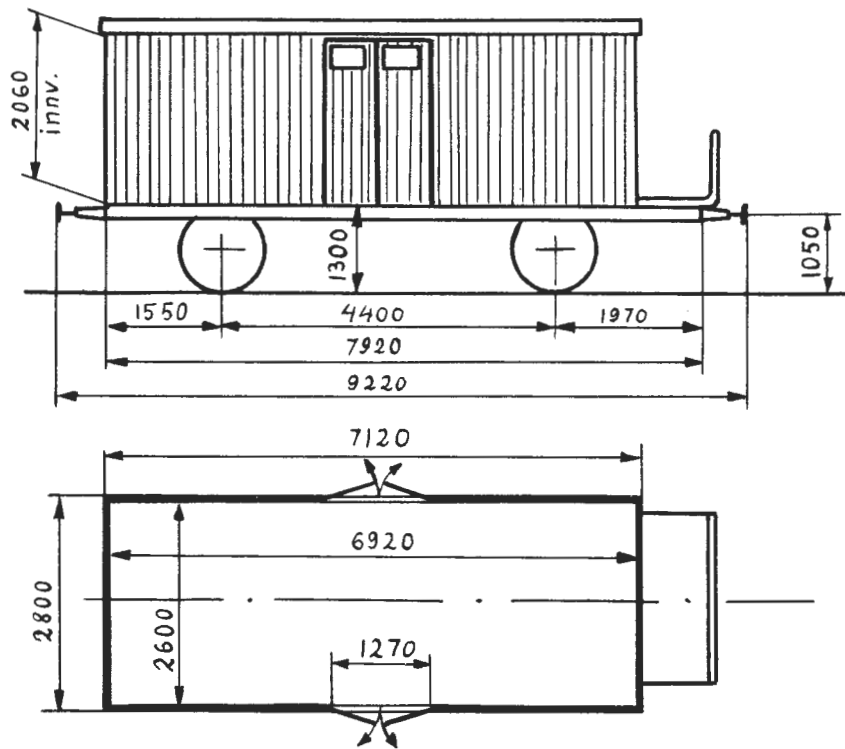

Grunnriss 1

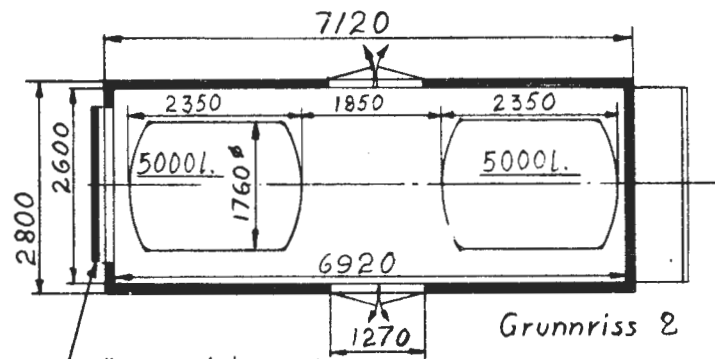

Grunnriss 2

Løs endelem for montering av tanker

Omtrentlig vognvekt 11,0-11,5 t
 " bæreevne 12,0-13,0 t
 Gulvflate 18,0 m²
 Rominnhold 36,7 m³
 Hovedtegning 2646 1)

MELKVOGN

Vogn nr.	Fabr.	Byggeår	Merknad	Vogn nr.	Fabr.	Byggeår	Merknad
2903	FMV	26	2)	2970	FMV	27	2)
2907	"	27	2)				
2908	"	"	3)				
2909	"	"	2)				
2910	"	"	2)				

1) Bremsarhuset er fjernet, og erstattet med bremsersplattform etter skisse nr. 1085. 2) Grunnriss 1. 3) Grunnriss 2.

Sf3

TYPE 1

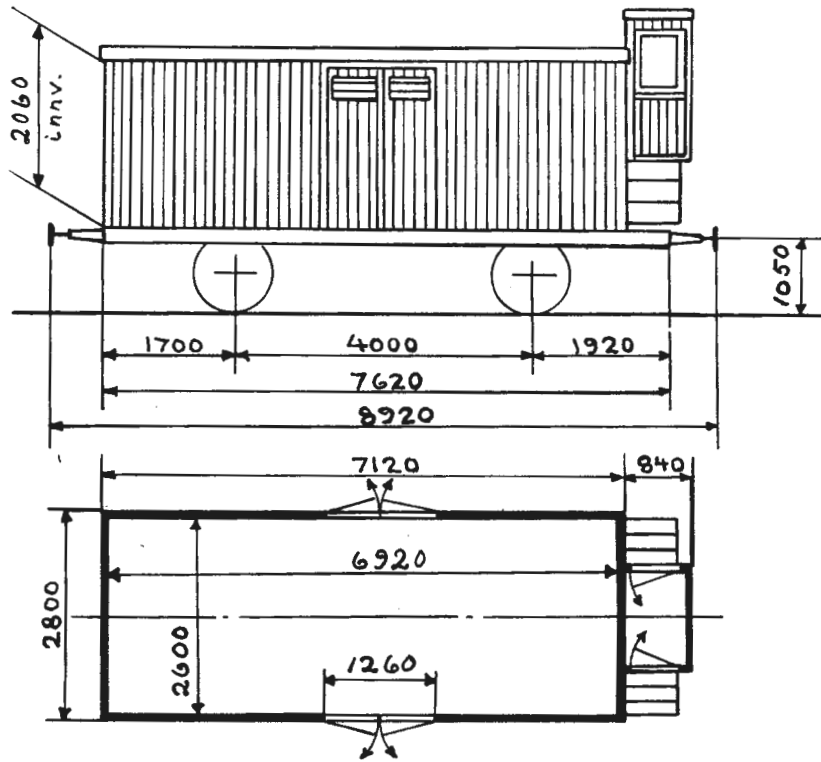

Bæreevne

A	B	C
12,0t	12,0t	

Omtrentlig vognvekt

11,5 t

Gulvflate

18,0 m²

Rominhold

36,7 m³

Hovedtegning

2275

MELKVOGN

Vogn nr.	Fabr.	Byggear	Merknad	Vogn nr.	Fabr.	Byggear	Merknad
4527	Edf	21					

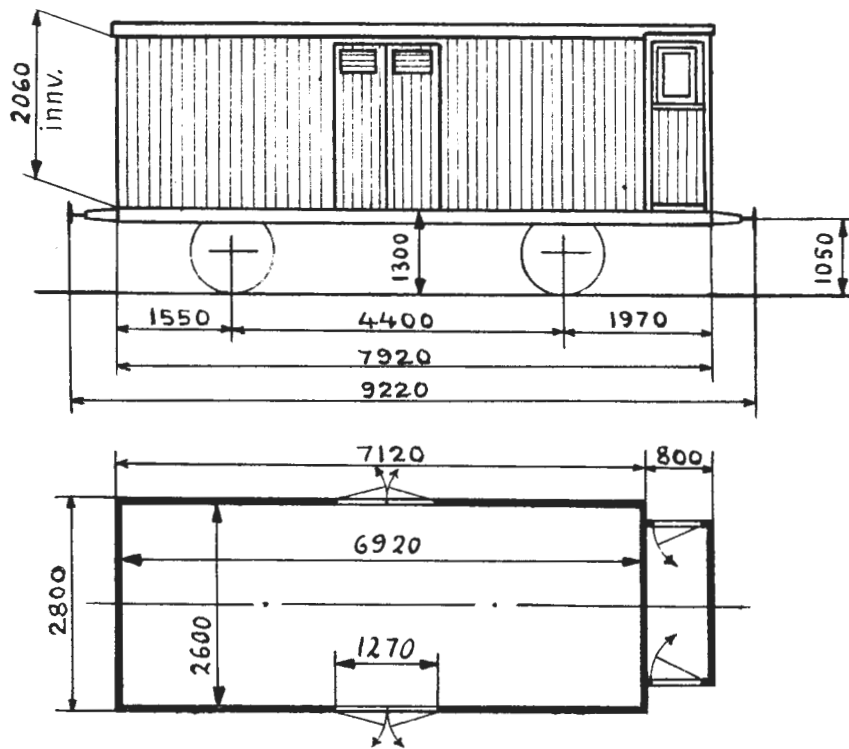

Omtrentlig vognvekt 11,0-12,0 t
 " bæreevne 12,0-12,5 t
 Gulvflate 18,0 m²
 Rominnhold 36,7 m³
 Hovedtegning 2646

MELKVOGN

Vogn nr.	Fabr.	Byggeår	Merknad	Vogn nr.	Fabr.	Byggeår	Merknad
2902	FMV	26					
2904	"	"					
2905	"	"					
2906	"	"					
9251	"	"					
9252	"	"					
16587	Skb	29					
16588	"	"					

T
TYPE 1

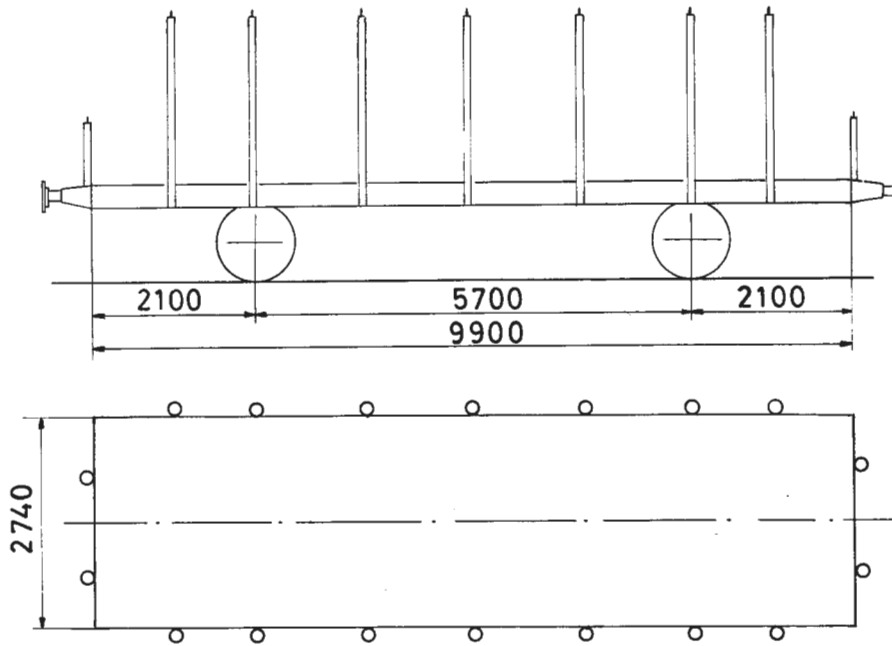

Bæreevne

A	B	C
20,0t	20,0t	

Omtrentlig vognvekt 9,5 t

Gulvflate 28,4m²

Rominhold —

Hovedtegning Stb.v.O.sk.nr.996

PLATTFORMVOGN

Vogn nr.	Fabr.	Byggeår	Merknad	Vogn nr.	Fabr.	Byggeår	Merknad
38601	1)	2)					

1) Omb. i Oslo i 1962. 2) Oppr. byggeår ukjent.

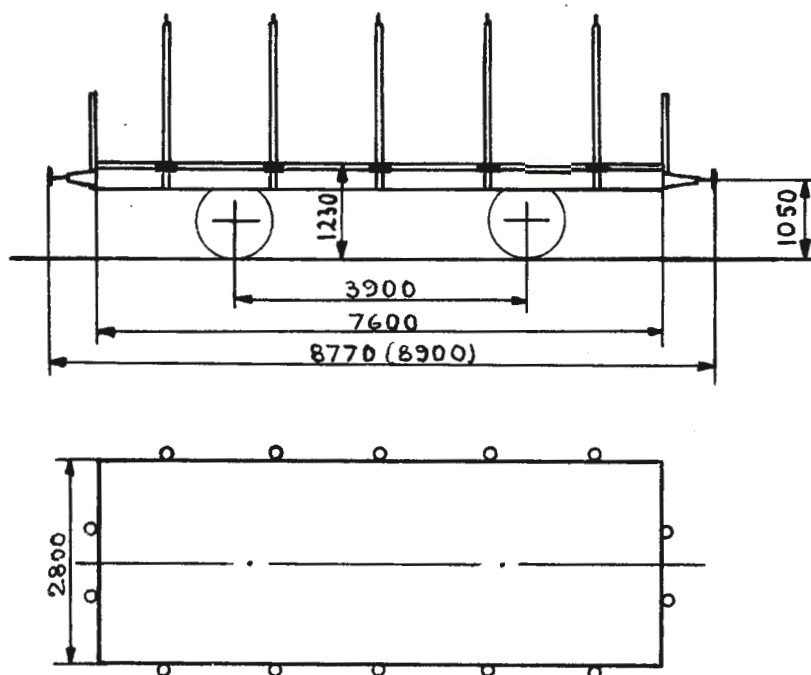

Omtrentlig vognvekt 6,5- 8,5 t
 " bæreevne 15,5-17,5 t
 Gulvflate 21,3 m²
 Rominnhold -
 Hovedtegning 1458,
 1458+2278 1)

PLATTFORMVOGN

Vogn nr.	Fabr.	Byggeår	Merknad	Vogn nr.	Fabr.	Byggeår	Merknad
2985	Str	16		4809	Str	13	3)
2988	"	"		4810	"	"	3)
2990	"	"		4811	"	"	3)
2992	"	"		4812	"	"	3)
2993	"	"		4813	"	"	
2999	"	"		4814	"	"	
4238	Skb	28	2)	4815	"	"	3)
4243	"	"	2)	4816	"	"	
4802	Str	13		4817	"	"	3)
4803	"	"	3)	4819	"	"	
4804	"	"	3)	4820	"	"	3)
4805	"	"	3)	4821	"	"	
4806	"	"	3)	4822	"	"	3)
4807	"	"	3)	4823	"	"	3)
4808	"	"		4824	"	"	3)

1) Vogner med tilleggstejn. 2278 har bremserplattform. Bremserhuset på denne tegn. er erstattet med bremserplattform etter tegn. 3291 og 3292. 2) Hovedt. 1458+2278. 3) Høye endelemmer.

Vogn nr.	Fabr.	Byggeår	Merknad	Vogn nr.	Fabr.	Byggeår	Merknad
4825	Str	13	3)	4863	Str	13	
4826	"	"	3)	4864	"	"	3)
4827	"	"		4865	"	"	
4828	"	"		4866	"	"	
4829	"	"		4867	"	"	
4830	"	"		4868	"	"	
4831	"	"	3)	4869	"	"	3)
4833	"	"	3)	4870	"	"	3)
4834	"	"	3)	4871	"	"	
4835	"	"	3)	4872	"	"	
4836	"	"	3)	4873	"	"	
4837	"	"		4874	"	"	3)
4838	"	"	3)	4875	"	"	
4839	"	"		4876	"	"	3)
4840	"	"	3)	4877	"	"	
4842	"	"		4878	"	"	
4843	"	"	3)	4879	"	"	3)
4844	"	"	3)	4880	"	"	
4845	"	"	3)	4882	"	"	3)
4846	"	"		4883	"	"	
4847	"	"	3)	4884	"	"	
4848	"	"		4885	"	"	3)
4849	"	"	3)	4886	"	"	
4850	"	"	3)	4887	"	"	
4851	"	"		4888	"	"	3)
4853	"	"	3)	4890	"	"	
4854	"	"	3)	4892	Skb	18	
4855	"	"	3)	4894	"	"	
4856	"	"		4895	"	"	
4857	"	"	3)	4896	"	"	
4858	"	"	3)	4902	"	"	
4859	"	"		4905	"	"	
4860	"	"		4907	FMV	25	2)
4861	"	"	3)	4911	"	"	2)
4862	"	"	3)	5375	Edf	25	

2) Hovedt. 1458+2278. 3) Höye endelemmer.

Vogn nr.	Fabr.	Byggeår	Merknad	Vogn nr.	Fabr.	Byggeår	Merknad
5380	Edf	25		6545	Skb	14	3)
5381	"	"		6546	"	"	3)
5392	Skb	27		6547	"	"	
5393	"	"		6548	"	"	3)
5394	"	"		6549	"	"	3)
5400	Str	"		6550	"	"	
5468	"	"		6551	"	"	3)
5469	"	"		6552	"	"	3)
5470	"	"		6553	"	"	
5472	"	"		6554	"	"	
5755	Edf	25		6555	"	"	
5757	"	"		6557	"	"	
5760	"	"		6558	"	"	
5762	"	"		6559	"	"	3)
5764	"	"		6560	"	"	
6213	Str	20		6561	"	"	
6214	"	"		6562	"	"	
6215	"	"		6563	"	"	3)
6221	"	"		6564	"	"	
6225	"	"		6565	"	"	
6229	"	"		6566	"	"	3)
6236	"	"		6568	"	"	
6237	"	"		6569	"	"	3)
6241	"	"		6571	"	"	3)
6243	"	"		6573	"	"	3)
6245	"	"		6574	"	"	3)
6247	"	"		6575	"	"	3)
6536	Skb	14	3)	6576	"	"	
6537	"	"	3)	6577	"	"	3)
6538	"	"	3)	6578	"	"	3)
6539	"	"		6579	"	"	3)
6540	"	"		6580	"	"	
6541	"	"		6581	"	"	3)
6543	"	"	3)	6582	"	"	
6544	"	"		6583	"	"	3)

3) Höye endelemmer.

Vogn nr.	Fabr.	Byggear	Merknad	Vogn nr.	Fabr.	Byggear	Merknad
6584	Skb	14		6627	Str	14	
6585	"	"	3)	6629	"	"	
6586	"	"	3)	6630	"	"	
6587	"	"	3)	6632	"	"	
6588	"	"	3)	6633	"	"	3)
6591	"	"	3)	6634	"	"	
6592	"	"		6636	"	"	
6593	"	"		6637	"	"	3)
6594	"	"	3)	6639	"	"	
6595	"	"	3)	6640	"	"	
6596	"	"		6641	"	"	
6597	"	"		6642	"	"	
6598	"	"		6643	"	"	
6599	"	"	3)	6644	"	"	
6600	"	"		6645	"	"	
6601	"	"	3)	6646	"	"	3)
6602	"	"	3)	6649	"	"	3)
6603	"	"	3)	6650	"	"	3)
6604	"	"		6651	"	"	3)
6605	"	"		6652	"	"	3)
6608	"	"		6653	"	"	3)
6609	"	"	3)	6654	"	"	
6610	"	"		6655	"	"	
6611	Str	"		6656	"	"	
6612	"	"		6658	"	"	
6613	"	"	3)	6659	"	"	3)
6614	"	"	3)	6660	"	"	
6615	"	"		6783	Skb	19	
6617	"	"		6785	"	"	
6618	"	"		6787	"	"	
6619	"	"	3) 4)	6790	"	"	
6620	"	"		6791	"	"	
6621	"	"		6793	"	"	
6622	"	"		6796	"	"	
6626	"	"	3)	6797	"	"	

3) Höye endelemmer. 4) Tank for transport av levende fisk.

Vogn nr.	Fabr.	Byggear	Merknad	Vogn nr.	Fabr.	Byggear	Merknad
6824	Skb	19		10683	LH	21	
6827	FMV	23	2)	10684	"	"	
6830	"	"	2)	10687	"	"	
6839	"	"	2)	10690	"	"	
6840	"	"	2)	10696	"	"	
6866	"	"	2)	10698	"	"	
6873	"	"	2)	10915	"	20	
6877	"	"	2)	10924	"	21	2)
6893	"	24	2)	10925	"	"	2)
6898 6899 10448	Str	16	2)	10929	"	"	2)
10449	"	"		10940	FMV	23	2)
10462	Skb	19		10949	"	"	2)
10467	"	"		10957	"	"	2)
10476	"	"		10958	"	"	2)
10478	"	"		10962	"	"	2)
10481	"	"		10976	"	25	
10489	"	"		10980	"	"	
10491	"	"		10987	"	"	
10493	"	"		10990	"	"	
10496	"	"		10991	"	"	
10500	"	"		10992	"	"	
10528	"	20		11936	Str	16	
10543	"	21	2)	11937	"	"	
10591	Str	20	2)	11938	"	"	3)
10593	"	"	2)	11939	"	"	
10595	"	"	2)	11940	"	"	3)
10597	"	"	2)	11941	"	"	3)
10658	"	"		11942	"	"	3)
10659	"	"		11943	"	"	
10661	"	"		11944	"	"	3)
10663	"	"		11945	"	"	
10665	"	"		14499	"	14	3)
10673	LH	21		14500	"	"	3)
10675	"	"		14502	"	"	3)
10680	"	"		14503	"	"	3)

2) Hovedt. 1458+2278. 3) Høye endelemmer.

T3
TYPE 1

Vogn nr.	Fabr.	Byggear	Merknad	Vogn nr.	Fabr.	Byggear	Merknad
14504	Str	14		15548	Str	22	
14505	"	"	3)	15556	"	"	
14506	"	"	3)	15558	"	"	
14507	"	"	3)	15570	"	"	
14508	"	"	3)	15571	FMV	25	
14509	"	"	3)	15573	"	"	
14511	"	"		15574	"	"	
14512	"	"		15579	"	"	
14513	"	"	3)	15582	"	"	
14514	"	"	3)	15583	"	"	
14515	"	"	3)	15586	"	"	
14516	"	"	3)	15587	"	"	
14517	"	"		15590	"	"	
14519	"	"	3)	16478	Edf	"	
14520	"	"	3)	16480	"	"	
14521	"	"		16484	"	"	
14522	"	"		16488	"	"	
14524	"	"	3)	16492	FMV	"	2)
14525	"	"	3)	16494	"	26	2)
14526	"	"	3)	16519	Str	27	
14527	"	"		16522	"	"	
14528	"	"		16526	"	"	
14530	"	16		16532	"	28	
14538	"	"		16533	"	"	
14542	"	"		16534	"	"	
14546	"	"		16536	"	"	
14548	"	"		16538	"	"	
14549	"	"		16540	"	"	
14550	"	"		16544	"	"	
14554	"	"		16548	"	"	
14560	"	"		17001	"	14	3)
14566	"	"		17002	"	"	
14567	"	"		17003	"	"	
15540	"	"		17004	"	"	3)
15544	"	"		17005	"	"	3)

2) Hovedt. 1458+2278. 3) Høye endelemer.

Vogn nr.	Fabr.	Byggear	Merknad	Vogn nr.	Fabr.	Byggear	Merknad
17006	Str	14	3)	17106	LH	21	3)
17007	"	"	3)	17107	"	"	3)
17008	"	"	3)	17108	"	"	3)
17009	"	"		17109	"	"	
17010	"	"	3)	17110	"	"	3)
17011	"	"	3)	17111	"	"	3)
17012	"	"	3)	17112	"	"	
17013	"	"		17113	"	"	3)
17014	"	"	3)	17114	"	"	3)
17015	"	"		17115	"	"	3)
17016	"	"	3)	17116	"	"	3)
17017	"	"		17117	"	"	
17018	"	"		17118	"	"	
17019	"	"		17119	"	"	
17020	"	"	3)	17120	"	"	
17021	"	"		17121	"	"	
17023	"	"	3)	17122	"	"	3)
17024	"	"		17123	"	"	
17025	"	"		17124	"	"	3)
17028	Skb	19		17125	"	"	3)
17091	LH	21	3)	17126	"	"	
17092	"	"	3)	17127	"	"	
17093	"	"	3)	17128	"	"	
17094	"	"		17129	"	"	3)
17095	"	"	3)	17130	"	"	3)
17096	"	"	3)	17131	"	"	
17097	"	"	3)	17132	"	"	3)
17098	"	"	3)	17133	"	"	
17099	"	"	3)	17134	"	"	
17100	"	"	3)	17135	"	"	3)
17101	"	"		17136	"	"	
17102	"	"	5)	17137	"	"	
17103	"	"	3)	17141	"	"	
17104	"	"	3)	17148	"	"	
17105	"	"	3)	17162	"	"	

3) Höye endelemmer. 5) Påmont. ploganordning for nedlegging av kabel.

Vogn nr.	Fabr.	Byggeår	Merknad	Vogn nr.	Fabr.	Byggeår	Merknad
17551	Skb	22	3)				
17552	"	"	3)				
17553	"	"					
17554	"	"	3)				
17555	"	"					
17558	"	"	3)				
17559	"	"	3)				
17560	"	"	3)				
17561	"	"					
17562	"	"	3)				
17563	"	"					

3) Höye endelemmer.

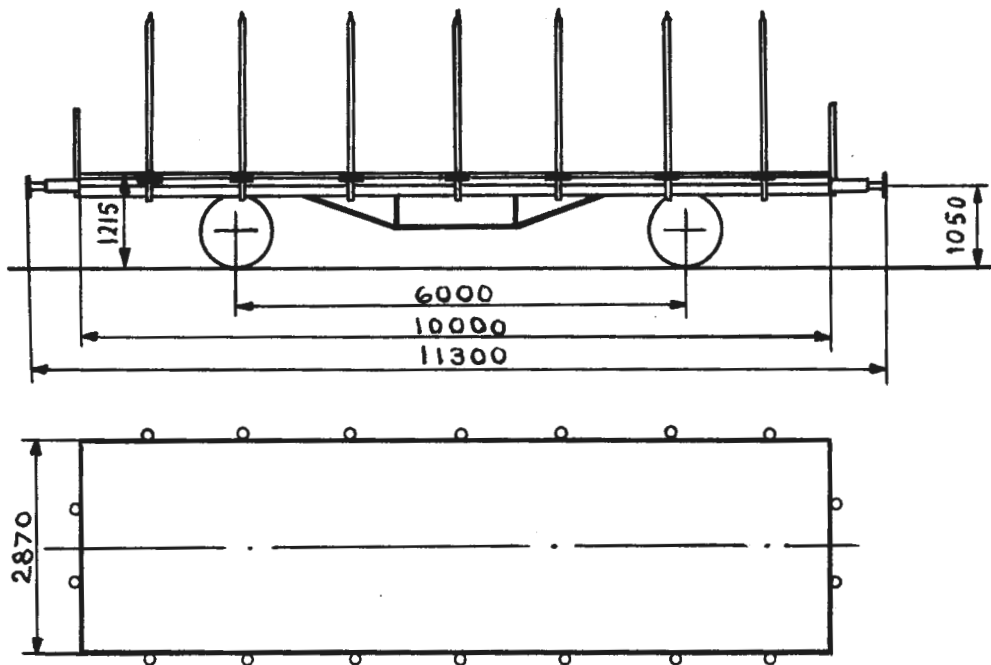

Bæreevne

A	B	C
21,0t	21,0t	

Omtrentlig vognvekt 8,0-10,0 t₂
 Gulvflate 28,7 m²
 Rominnhold -
 Hovedtegning 3250 eller 3770

PLATTFORMVOGN

Vogn nr.	Fabr.	Byggeår	Merknad	Vogn nr.	Fabr.	Byggeår	Merknad
			Hovedt. 3250	60017	Skb	32	
60001	Skb	32		60018	"	"	
60002	"	"		60019	"	"	
60003	"	"		60021	"	"	
60004	"	"		60022	"	"	
60005	"	"		60023	"	" 2)	
60006	"	"		60026	"	"	
60008	"	"		60027	"	"	
60009	"	"		60028	"	"	
60010	"	"		60029	"	"	
60011	"	"		60030	"	"	
60012	"	"		60031	"	33	
60013	"	"		60032	"	"	
60014	"	"		60033	"	"	
60016	"	"		60035	"	"	

2) Utstyr for transport av jernbaneskinner.

T4
TYPE 1

Vogn nr.	Fabr.	Byggeår	Merknad	Vogn nr.	Fabr.	Byggeår	Merknad
60037	Skb	33		60075	Skb	35	
60038	"	"		60076	"	"	
60039	"	"		60077	"	"	
60040	"	"		60078	"	"	
60041	"	"		60079	"	"	
60042	"	"		60081	"	"	
60044	"	"		60082	"	"	
60045	"	"		60083	"	"	
60046	"	"		60084	"	"	
60047	"	"		60085	"	"	
60048	"	"		60086	"	"	
60049	"	"		60087	"	"	
60050	"	"		60088	"	"	
60052	"	"		60089	"	"	
60053	"	"		60090	"	"	
60054	"	"		60091	"	"	
60055	"	"		60092	"	"	
60056	"	"		60093	"	"	4)
60057	"	"		60094	"	"	
60058	"	"		60095	"	"	
60059	"	"		60096	"	"	
60060	GMV	"	1)	60097	"	"	
60061	"	"		60098	"	"	
60062	"	"		60099	"	"	
60064	"	"		60100	"	"	
60065	"	"		60101	"	"	
60066	"	"		60102	"	"	
60067	"	"		60103	"	"	
60068	"	"		60104	"	"	
60069	"	"		60107	"	"	
			Hovedt. 3770	60108	"	"	
60070	Skb	35		60110	"	"	
60071	"	"		60111	"	"	
60072	"	"	2)	60112	"	"	
60073	"	"		60113	"	"	

1) Påmontert beholdere for lut i pulverform. 2) Utstyr for transport av jernbaneskiner. 4) Utstyr for transport av beholdere for lössement.

Vogn nr.	Fabr.	Byggeår	Merknad	Vogn nr.	Fabr.	Byggeår	Merknad
60114	Skb	35		60156	Str	35	
60116	"	"		60157	"	"	
60118	"	"		60158	"	"	
60119	"	"		60159	"	"	
60120	Str	"		60160	"	"	
60122	"	"		60161	"	"	
60123	"	"		60162	"	"	
60124	"	"		60164	"	"	
60125	"	"		60166	"	"	
60126	"	"		60167	"	"	
60128	"	"		60168	"	"	
60129	"	"		60170	Skb	36	
60130	"	"		60171	"	37	
60132	"	"		60172	"	"	
60133	"	"		60173	"	"	
60134	"	"		60174	"	"	
60135	"	"	4)	60176	"	"	
60137	"	"		60178	"	"	
60138	"	"		60179	"	"	
60139	"	"		60181	"	"	
60140	"	"		60182	"	"	
60141	"	"		60184	"	"	
60142	"	"		60185	"	"	
60143	"	"		60186	"	38	
60144	"	"		60187	"	"	
60145	"	"		60189	"	"	
60146	"	"		60191	"	"	
60147	"	"	2)	60194	"	"	3)
60148	"	"		60195	"	"	
60149	"	"		60196	"	"	
60150	"	"		60197	"	"	
60151	"	"		60198	"	"	
60152	"	"		60199	"	"	
60153	"	"		60200	"	"	
60154	"	"		60201	"	"	2)

2) Utstyr for transport av jernbaneskiner. 3) Utstyr for transport av trefiberplater. 4) Utstyr for transport av beholdere for løsement.

T4
TYPE 1

Vogn nr.	Fabr.	Byggeår	Merknad	Vogn nr.	Fabr.	Byggeår	Merknad
60203	Skb	38		60581	Skb	46	
60204	"	"		60586	"	"	
60205	"	"		60606	"	"	
60228	"	37		60628	Str	44	
60232	"	"		60642	"	"	
60246	"	"		60653	"	"	
60247	"	"		60665	"	"	
60258	"	38		60671	"	"	
60268	"	"		60684	"	"	
60283	"	"		60686	"	"	
60286	"	39		60693	"	45	
60293	"	"		60697	Skb	46	
60295	"	"		60749	"	47	
60299	"	38		60750	"	"	
60312	"	39		60753	"	"	
60320	"	"		60759	"	"	
60353	"	40		60760	"	"	
60361	"	"		60765	"	"	
60368	"	"		60771	Str	"	
60375	"	"		60786	"	48	
60381	"	39		60792	"	"	
60401	Edf	40		60793	"	"	
60413	"	"		60811	"	"	
60415	"	"		60814	"	"	
60501	Skb	42		60820	"	"	
60516	"	"		60828	"	"	
60517	"	"		60832	"	"	
60520	"	"		60842	"	50	
60530	"	"		60843	"	"	
60531	"	"		60864	"	"	
60535	"	"		60889	"	51	
60538	"	"		60904	"	"	
60562	"	46		60920	"	52	
60571	"	"		60922	"	"	
60578	"	"		60927	"	"	
				60929	"	"	

Vogn nr.	Fabr.	Byggeår	Merknad	Vogn nr.	Fabr.	Byggeår	Merknad
60933	Str	52		61155	Str	53	
60945	Edf	50		61159	"	"	
60953	"	"		61163	"	"	
60956	"	"		61166	"	"	
60958	"	"		61177	"	"	
60965	"	"		61182	"	"	
60975	"	"		61187	"	"	
60978	"	"		61189	"	"	
60983	"	"		61213	Edf	54	
60987	"	"		61246	Hök	"	5)
60991	"	"		61261	"	"	
61007	"	"		61264	"	"	
61024	"	"		61267	"	"	
61027	"	"					
61034	"	"					
61058	"	"					
61064	"	51					
61075	Str	52					
61077	"	"					
61086	"	"					
61093	"	"					
61102	"	"					
61105	"	"					
61108	"	"					
61109	"	"					
61110	"	"					
61115	"	"					
61134	"	"					
61137	"	53					
61140	"	"					
61144	"	"					
61145	"	"					
61146	"	"					
61148	"	"					
61153	"	"					

5) Elektrisk varmekabel og transformator (1000/220 V) for margarin-
oljetransport.

T4 type 1-vogner med internasjonal litrering og nummerering.

Vogn nr.	Fabr.	Byggeår	Merknad	Vogn nr.	Fabr.	Byggeår	Merknad
21 76 312 7000-6	Skb	32		21 76 312 7254-9	Str	48	
312 7007-1	"	"		312 7259-8	Edf	50	
312 7014-7	"	"		312 7269-7	"	"	
312 7019-6	"	"		312 7270-5	Str	"	
312 7022-0	"	"		312 7271-3	Skb	40	
312 7023-8	"	"		312 7272-1	Str	44	
312 7032-9	"	33		312 7273-9	"	48	
312 7034-5	"	"		312 7274-7	Edf	50	
312 7041-0	"	"		312 7275-4	"	54	
312 7060-0	GMV	"		312 7276-2	Skb	46	
312 7070-9	Skb	35		312 7277-0	Str	48	
312 7098-0	"	"		312 7278-8	"	44	
312 7099-8	"	"		312 7279-6	Edf	51	
312 7116-0	Str	"	60112	312 7280-4	Str	52	
312 7120-2	"	"		312 7281-2	Hök	54	
312 7125-1	"	"		312 7282-0	Skb	38	
312 7144-2	"	"		312 7283-8	Str	48	
312 7153-3	"	"	60112	312 7284-6	Edf	54	
312 7157-4	"	"		312 7285-3	Str	50	
312 7163-2	Skb	37		312 7286-1	Skb	36	
312 7168-1	"	"		312 7287-9	"	47	
312 7175-6	"	38		312 7288-7	Str	44	
312 7177-2	"	"		312 7289-5	Skb	39	
312 7179-8	"	"		312 7290-3	"	42	
312 7180-6	"	"		312 7291-1	"	39	
312 7189-7	"	"		312 7292-9	Str	50	
312 7203-6	"	42		312 7293-7	"	52	
312 7204-4	"	"		312 7294-5	Skb	37	
312 7208-5	"	46		312 7295-2	Str	44	
312 7209-3	"	"		312 7296-0	"	50	
312 7221-8	Edf	50		312 7297-8	Skb	39	
312 7222-6	Str	52		312 7298-6	"	"	
312 7244-0	"	44		312 7299-4	"	"	
312 7249-9	Skb	47		312 7300-0	"	37	
312 7251-5	Str	48		312 7301-8	"	42	

T4 type 1-vogner med internasjonal litrering og nummerering.

Vogn nr.	Fabr.	Byggear	Merknad	Vogn nr.	Fabr.	Byggear	Merknad
21 76 312 7302-6	Str	50					
312 7303-4	"	47					
312 7304-2	Skb	46					
312 7305-9	Str	44					
312 7306-7	Skb	40					
312 7307-5	Hök	54					
312 7308-3	Str	52					

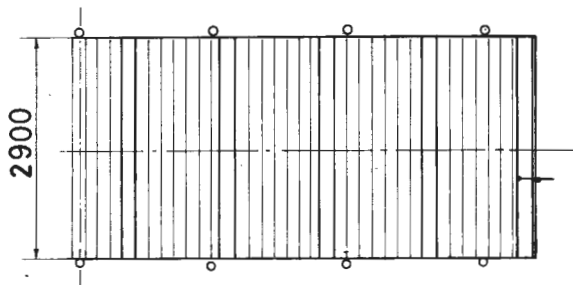
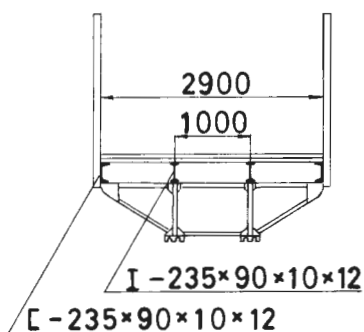
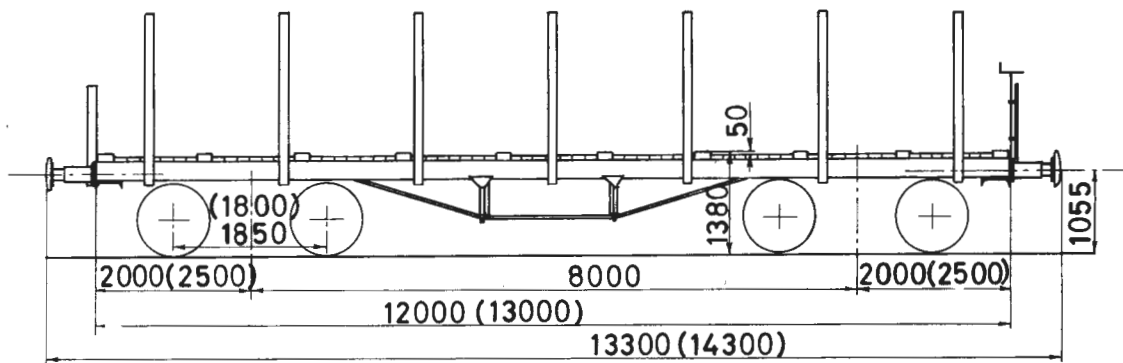

Omtrentlig vognvekt 16,0t

Hovedtegning 13955

Bæreevne

Jevnt fordelt last

Vogn nr.38202 og 38209

A	B	C
31,0t		31,0t

Vogn nr.38216

A	B	C
37,0t		37,0t

Konsentrerte belastninger

	m	t
a-a	1	15
b-b	5	19
c-c	8	25
d-d	10	31

*37,0 for vogn nr38216

PLATT FORMVOGN

Vogn nr.	Fabr.	Byggeår	Merknad	Vogn nr.	Fabr.	Byggeår	Merknad
38202	-	-					
38209	-	-					
38216	-	-					

Mål i () gjelder for vogn nr. 38209

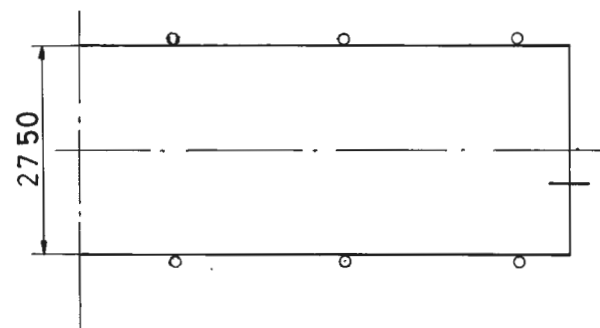
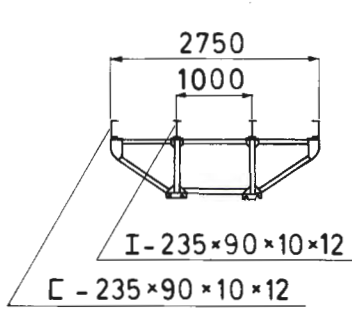
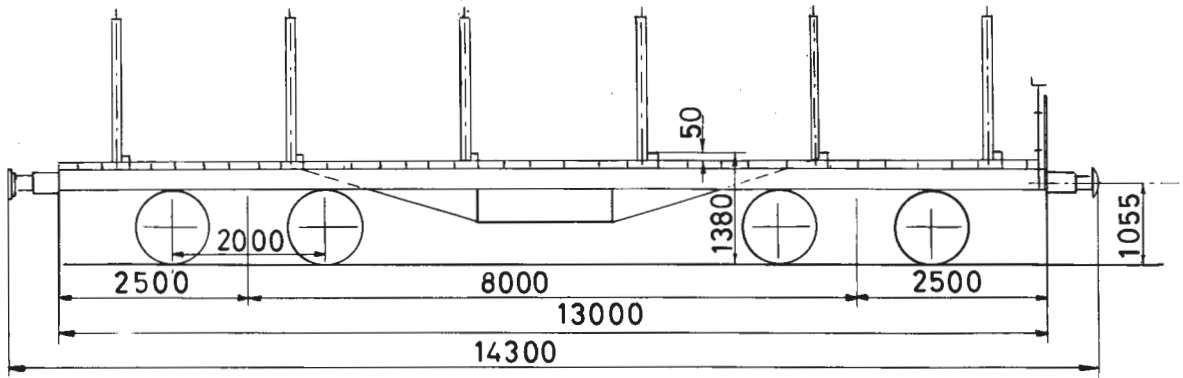

Omtrentlig vognvekt 16,0t

Hovedtegning 13955

Bæreevne

Jevnt fordelt last

A	B	C
37,0t	37,0t	

Konsentrerte belastninger

	m	t
a-a	1	14
b-b	5	17
c-c	8	25
d-d	10	37

PLATTFORMVOGN

Vogn nr.	Fabr.	Byggeår	Merknad	Vogn nr.	Fabr.	Byggeår	Merknad
38211	-	-					

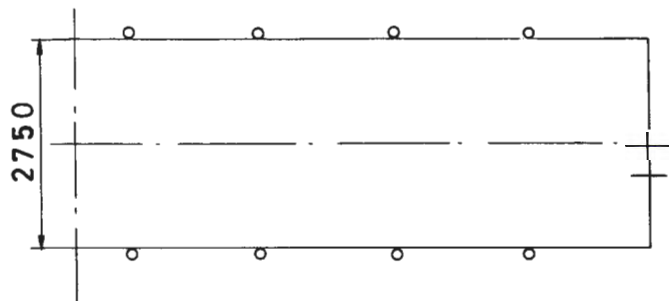
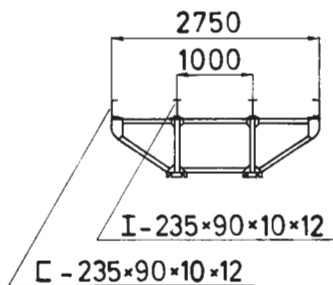
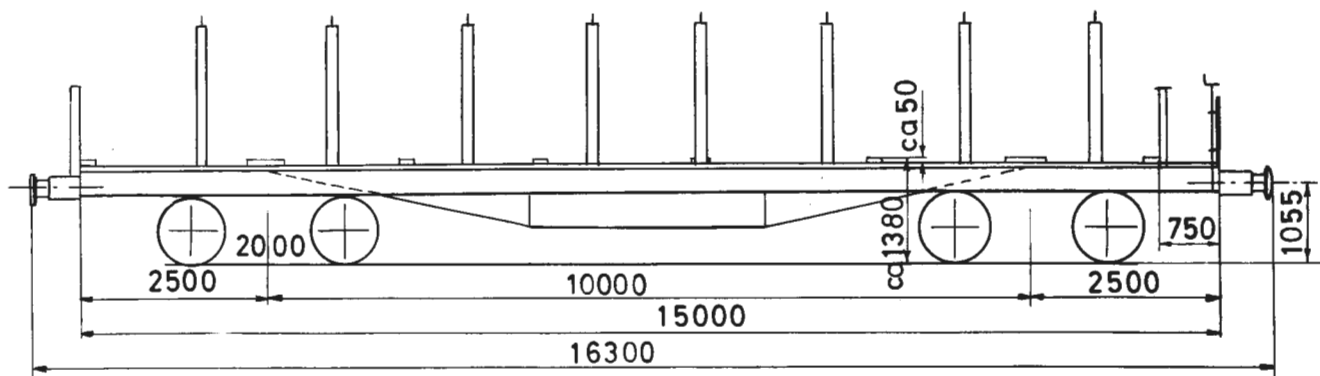

Omtrentlig vognvekt 18,0-20,5 t

Hovedtegning 13956

Bæreevne

Jevnt fordelt last

A	B	C
37,0t		37,0t

Konsentrerte belastninger

	m	t
a-a	1	14
b-b	5	16
c-c	9	21
d-d	12	32
e-e	13	37

PLATTFORMVOGN

Vogn nr.	Fabr.	Byggeår	Merknad	Vogn nr.	Fabr.	Byggeår	Merknad
38212	-	-	Vegg ved bremsepl.f. fjernet				
38218	-	-					
38226	-	-					

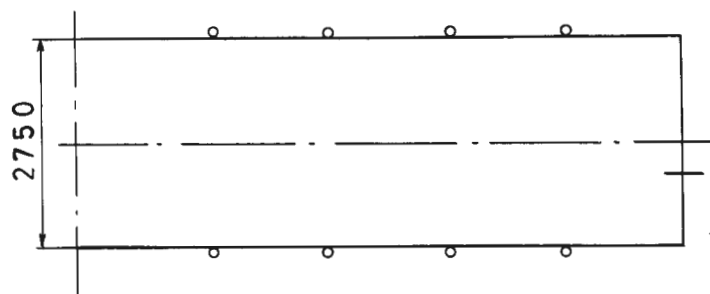
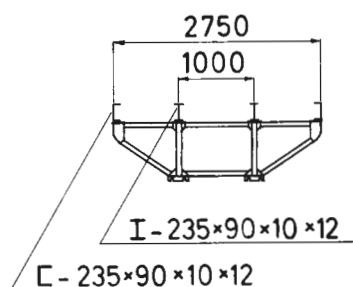
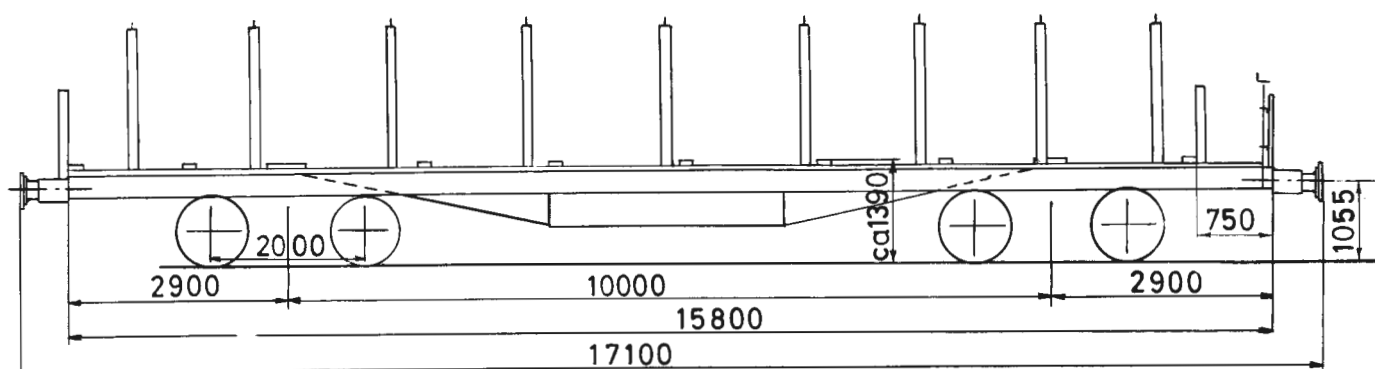

Omtrentelig vognvekt 18,5-20,5 t

Hovedtegning 13957 eller 13958

Bæreevne

Jevnt fordelt last

A	B	C
37,0t		37,0t

Konsentrerte belastninger

	m	t
a-a	1	14
b-b	3	16
c-c	7	21
d-d	10	24
e-e	13	37

PLATTFORMVOGN

Vogn nr.	Fabr.	Byggeår	Merknad	Vogn nr.	Fabr.	Byggeår	Merknad
38204	MAN	19	2)	38222	-	-	2)
38206	-	-	2)	38224	HCK	21	2)
38207	-	-	2)	38228	-	-	2)
38208	-	-		38238	-	-	2)
38213	MAN	14	1)	38244	MAN	14	1) Vegg ved br.pl.f. fjernet
38214	RMM	21	2)	38245	LH	12	
38220	MAN	10	2)	38248	-	-	2)
38221	-	-	2)				

1) H.tegn. 13957 2) H.tegn. 13958

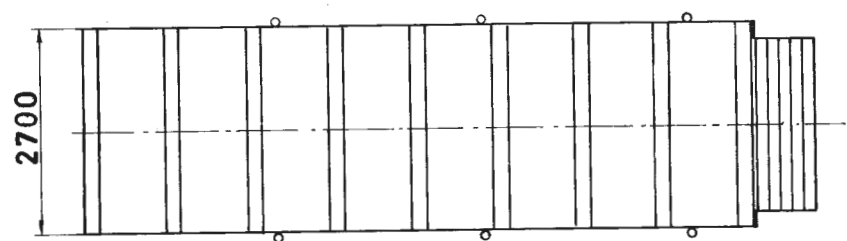
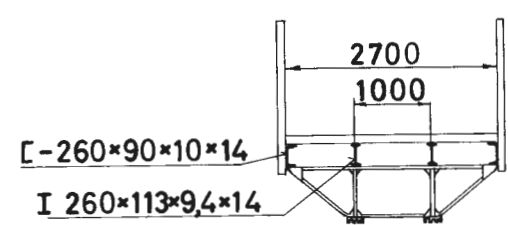
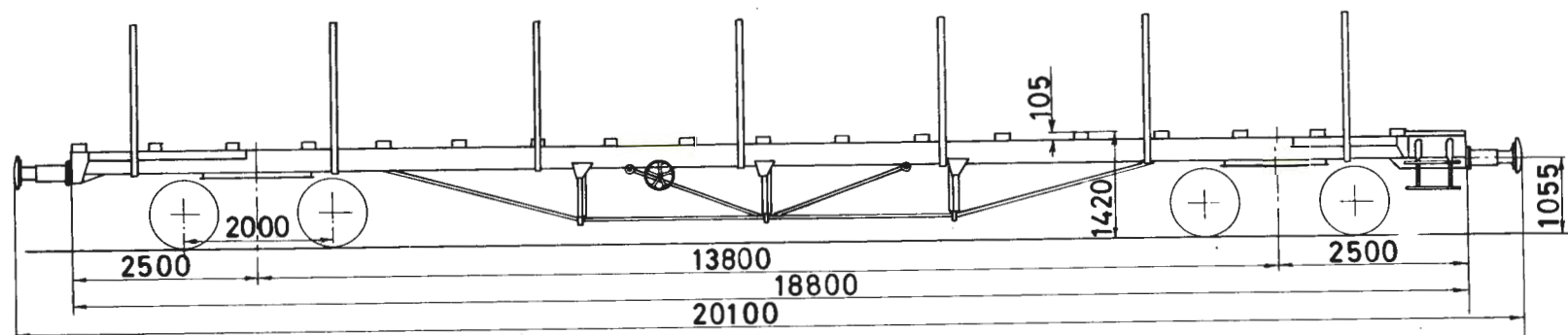

Konsentrerte belastninger

	m	t
a-a	1	25
b-b	6	27
c-c	10	30
d-d	14	38

Jevnt fordelt last

A	B	C
38,0t	38,0t	

Maks. belastning på hver vognende 90 t.

Omtrentlig vognvekt 19,5-23,0t
Hovedtegning 16204

PLATTFORMVOGN

Vogn nr.	Fabr.	Byggeår	Merknad	Vogn nr.	Fabr.	Byggeår	Merknad
38203	-	-		38241	-	-	
38227	LH	26		38242	-	-	
38229	FKM	23		38243	WM	23	
38240	LH	21					

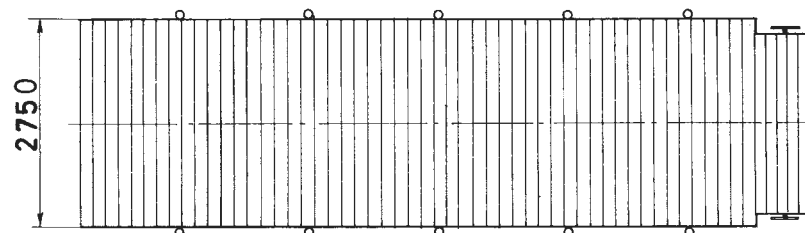
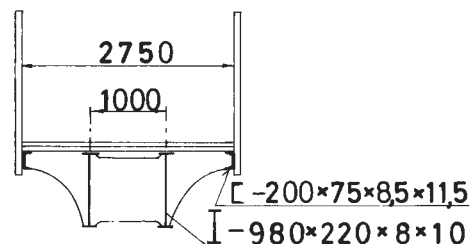
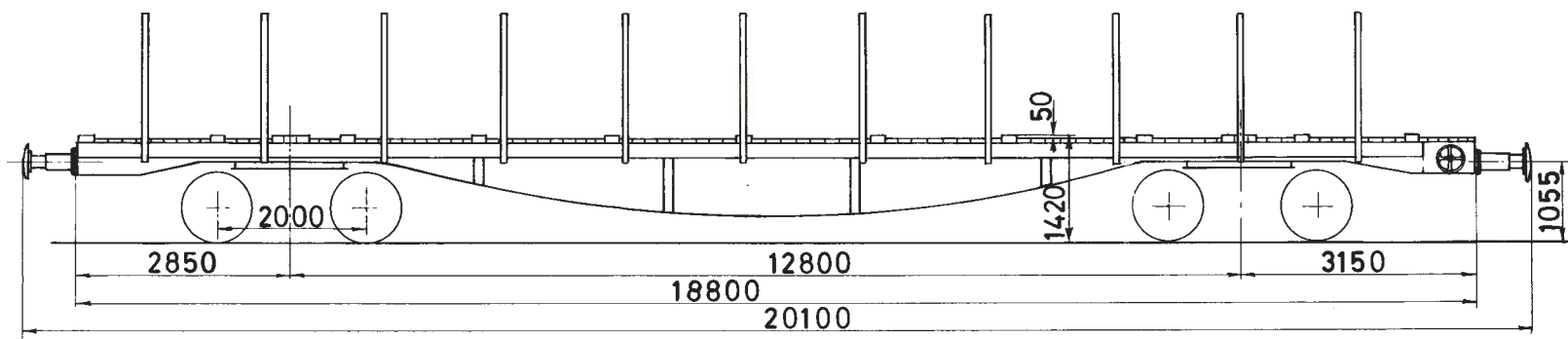

1) Konsentrerte belastninger

	m	t	x
a-a	1	22	22
b-b	3	23	27
c-c	10	28	28
d-d	12	32	39
e-e	15	39	39

Jevnt fordelt last

A	B	C
39,0t	39,0t	

Omtrentlig vognvekt 20,0-21,5 t.
Hovedtegning 16205 eller 16206

1) Maks. belastning på hver vognende 15,0 t.

PLATTFORMVOGN

Vogn nr.	Fabr.	Byggeår	Merknad	Vogn nr.	Fabr.	Byggeår	Merknad
38200	MAN	38	H-tegn.16205	38246	RSE	39	H-tegn.16205
38231	-	39	" 16206	38247	"	"	" "

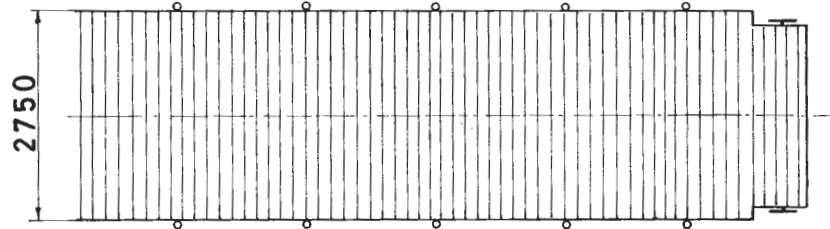
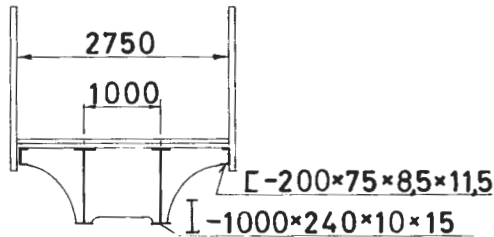
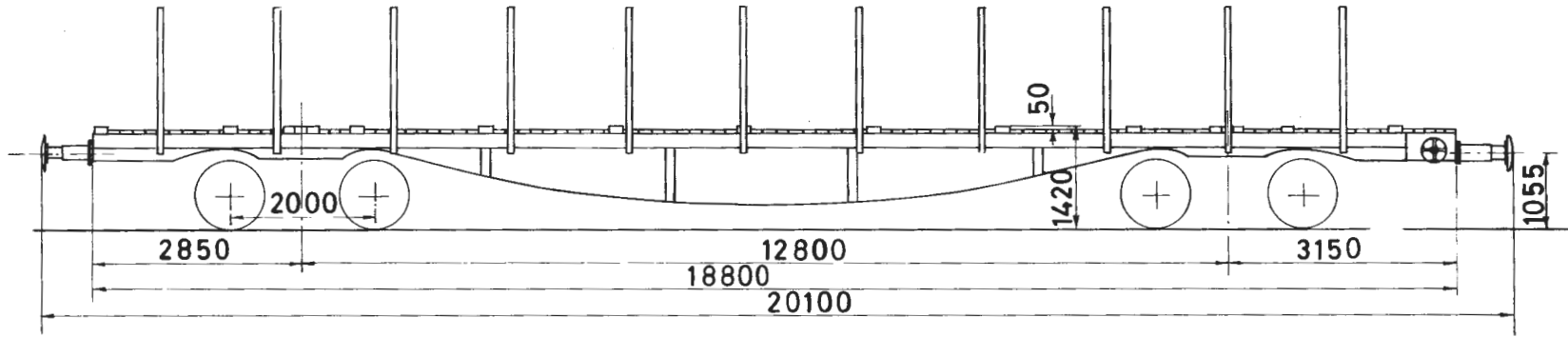

Konsentrerte belastninger

	m	t	
a-a	1	32	34
b-b	2	34	36
c-c	3	36	39
d-d	5	39	39

Jevnt fordelt last

A	B	C
39,0t	39,0t	

Omtrentlig vognvekt 20,5-21,5t.

Hovedtegning 16207

PLATTFORMVOGN

Vogn nr.	Fabr.	Byggeår	Merknad	Vogn nr.	Fabr.	Byggeår	Merknad
38201	LH	43		38234	RTW	44	
38232	WA _g	41		38236	LH	"	
38233	RTW	40		38237	"	"	

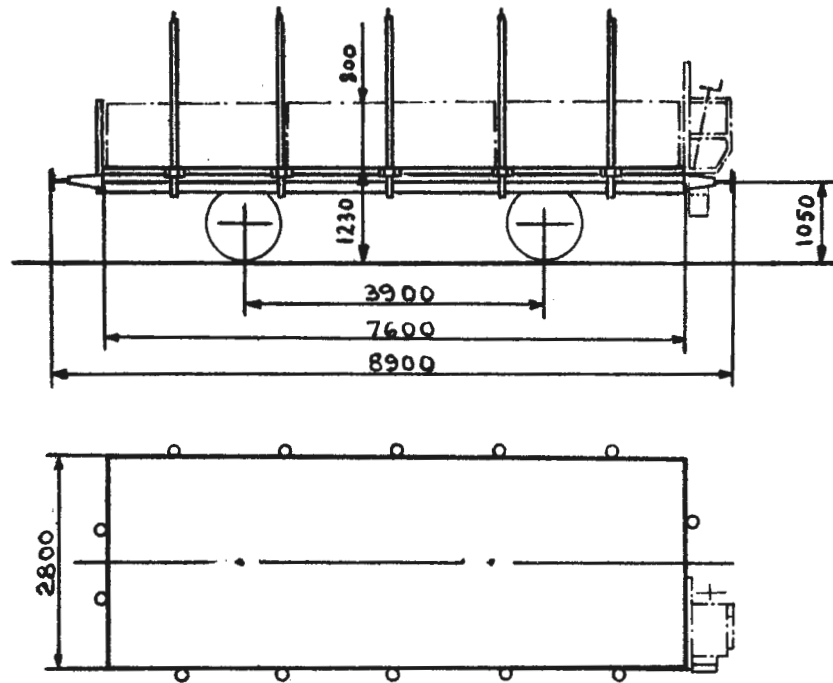

Bæreevne

A	B	C
16,0t	16,0t	

Omtrentlig vognvekt 7,0-8,5 t
 Gulvflate 21,3 m²
 Rominnhold 17,0 m³
 Hovedtegning 1458 + 2140,
 1458 + 2278 1)

PLATTFORMVOGN MED NEDLEGGBARE JERNLEMNER

Vogn nr.	Fabr.	Byggeår	Merknad	Vogn nr.	Fabr.	Byggeår	Merknad
			H-tegn. 1458 + 2140	4230	Skb	28	
✓ 2985	Str	16		4231	"	"	
2986	"	"		4232	"	"	
2987	"	"		4233	"	"	
✓ 2988	"	"		4234	"	"	
2989	"	"		4235	"	"	
✓ 2990	"	"		4236	"	"	
2991	"	"		4237	"	"	
2992	"	"		4238	"	"	
2993	"	"		4239	"	"	
2994	"	"		4240	"	"	
2995	"	"		4241	"	"	
2996	"	"		4242	"	"	
2997	"	"		✓ 4243	"	"	
2998	"	"		4244	"	"	
✓ 2999	"	"		4245	"	"	
			H-tegn. 1458 + 2278	4246	"	"	
4229	Skb	28					

1) Bare vogner med tilleggstejn. 2278 har bremslerplattform. Bremslerhuset på denne tegn. er erstattet med bremslerplattform etter tegn. 3291 og 3292.

Vogn nr.	Fabr.	Byggear	Merknad	Vogn nr.	Fabr.	Byggear	Merknad
4247	Skb	28					H-tegn. 1458 + 2140
4248	"	"		5369	Edf	25	
			H-tegn. 1458 + 2140	5370	"	"	
4891	Skb	18		5371	"	"	
✓ 4892	"	"		5372	"	"	
4893	"	"		5373	"	"	
4894	"	"		5374	"	"	
✓ 4895	"	"		5375	"	"	
4896	"	"		5376	"	"	
4897	"	"		5377	"	"	
4898	"	"		5378	"	"	
4899	"	"		5379	"	"	
4900	"	"		✓ 5380	"	"	
4901	"	"		5381	"	"	
✓ 4902	"	"		5382	"	"	
4904	"	"		5383	"	"	
✓ 4905	"	"					
			H-tegn. 1458 + 2278	5384	FMV	26	H-tegn. 1458 + 2278
4906	FMV	25		5385	"	"	
✓ 4907	"	"		5386	"	"	
4908	"	"		5387	"	"	
4909	"	"		5388	"	"	
4910	"	"					
✓ 4911	"	"		5389	Skb	27	H-tegn. 1458 + 2140
4912	"	"		5390	"	"	
4913	"	"		5391	"	"	
4914	"	"		✓ 5392	"	"	
4915	"	"		✓ 5393	"	"	
4916	"	"		5394	"	"	
4917	"	"		5395	"	"	
4918	"	"		5396	"	"	
4919	"	"		5397	"	"	
4920	"	"		5398	"	"	
4921	"	"		5399	Str	"	
4922	"	"		✓ 5400	"	"	
4923	"	"		5467	"	"	
4924	"	"		5468	"	"	
4925	"	"		5469	"	"	

Vogn nr.	Fabr.	Byggeår	Merknad	Vogn nr.	Fabr.	Byggeår	Merknad
5470	Str	27		6226	Str	20	
5471	"	"		6227	"	"	
5472	"	"		6228	"	"	
5473	"	"		6229	"	"	
5474	"	"		6230	"	"	
5751	Edf	25		6231	"	"	
5752	"	"		6232	"	"	
5753	"	"		6233	"	"	
5754	"	"		6234	"	"	
5755	"	"		6235	"	"	
5756	"	"		6236	"	"	
5757	"	"		6237	"	"	
5758	"	"		6238	"	"	
5759	"	"		6239	"	"	
5760	"	"		6240	"	"	
5761	"	"		6241	"	"	
5762	"	"		6242	"	"	
5763	"	"		6243	"	"	
5764	"	"		6244	"	"	
5765	"	"		6245	"	"	
6211	Str	20		6246	"	"	
6212	"	"		6247	"	"	
6213	"	"		6248	"	"	
6214	"	"		6249	"	"	
6215	"	"		6250	"	"	
6216	"	"		6781	Skb	19	
6217	"	"		6782	"	"	
6218	"	"		6783	"	"	
6219	"	"		6784	"	"	
6220	"	"		6785	"	"	
6221	"	"		6786	"	"	
6222	"	"		6787	"	"	
6223	"	"		6788	"	"	
6224	"	"		6789	"	"	
6225	"	"		6790	"	"	

Vogn nr.	Fabr.	Byggeår	Merknad	Vogn nr.	Fabr.	Byggeår	Merknad
6791	Skb	19		6870	FMV	23	
6792	"	"		6871	"	"	
6793	"	"		6872	"	"	
6794	"	"		6873	"	"	
6795	"	"		6874	"	"	
6796	"	"		6875	"	"	
6797	"	"		6876	"	"	
6798	"	"		6877	"	"	
6799	"	"		6878	"	"	
6800	"	"		6879	"	"	
6821	"	"		6880	"	24	
6822	"	"		6881	"	"	
6823	"	"		6882	"	"	
6824	"	"		6883	"	"	
6825	"	"		6884	"	"	
6826	FMV	23	H-tegn. 1458 + 2278	6885	"	"	
6827	"	"		6886	"	"	
6828	"	"		6887	"	"	
6829	"	"		6888	"	"	
6830	"	"		6889	"	"	
6831	"	"		6890	"	"	
6832	"	"		6891	"	"	
6833	"	"		6892	"	"	
6834	"	"		6893	"	"	
6835	"	"		6894	"	"	
6836	"	"		6895	"	"	
6837	"	"		6896	"	"	
6838	"	"		6897	"	"	
6839	"	"		6898	"	"	
6840	"	"		6899	"	"	
6865	"	"		6900	"	"	
6866	"	"		6997	"	"	
6867	"	"		6998	"	"	
6868	"	"		6999	"	"	
6869	"	"		7000	"	"	

Vogn nr.	Fabr.	Byggeår	Merknad	Vogn nr.	Fabr.	Byggeår	Merknad
			H-tegn. 1458 + 2140	10475	Skb	19	
10441	Str	16		10476	"	"	
10442	"	"		10477	"	"	
10443	"	"		10478	"	"	
10444	"	"		10479	"	"	
10445	"	"		10480	"	"	
10446	"	"		10481	"	"	
10447	"	"		10482	"	"	
10448	"	"		10483	"	"	
10449	"	"		10484	"	"	
10450	"	"		10485	"	"	
10451	"	"		10486	"	"	
10452	"	"		10487	"	"	
10453	"	"		10488	"	"	
10454	"	"		10489	"	"	
10455	"	"		10490	"	"	
10456	"	"		10491	"	"	
10457	"	"		10492	"	"	
10458	"	"		10493	"	"	
10459	"	"		10494	"	"	
10460	"	"		10495	"	"	
10461	Skb	19		10496	"	"	
10462	"	"		10497	"	"	
10463	"	"		10498	"	"	
10464	"	"		10499	"	"	
10465	"	"		10500	"	"	
10466	"	"		10526	"	20	
10467	"	"		10527	"	"	
10468	"	"		10528	"	"	
10469	"	"		10529	"	"	
10470	"	"		10530	"	"	
10471	"	"					
10472	"	"					H-tegn. 1458 +2278
10473	"	"		10531	Skb	21	
10474	"	"		10532	"	"	
				10533	"	"	

Vogn nr.	Fabr.	Byggeår.	Merknad	Vogn nr.	Fabr.	Byggeår	Merknad
10534	Skb	21		✓10665	Str	20	
10535	"	"		10666	LH	21	
10536	"	"		10667	"	"	
10537	"	"		10668	"	"	
10538	"	"		10669	"	"	
10539	"	"		10670	"	"	
10540	"	"		10671	"	"	
10541	"	"		10672	"	"	
10542	"	"		✓10673	"	"	
✓10543	"	"		10674	"	"	
10544	"	"		10675	"	"	
10545	"	"		10676	"	"	
10546	"	"		10677	"	"	
10547	"	"		10678	"	"	
10548	"	"		10679	"	"	
10549	"	"		✓10680	"	"	
10550	"	"		10681	"	"	
✓10591	Str	20		10682	"	"	
10592	"	"		10683	"	"	
✓10593	"	"		10684	"	"	
10594	"	"		10685	"	"	
✓10595	"	"		10686	"	"	
10596	"	"		10687	"	"	
10597	"	"		10688	"	"	
10598	"	"		10689	"	"	
10599	"	"		10690	"	"	
10600	"	"		10691	"	"	
			H-tegn. 1458+2140	10692	"	"	
10656	Str	20		10693	"	"	
10657	"	"		10694	"	"	
10658	"	"		10695	"	"	
10659	"	"		10696	"	"	
10660	"	"		10697	"	"	
10661	"	"		10698	"	"	
10662	"	"		10699	"	"	
10663	"	"		10700	"	"	
10664	"	"					

Vogn nr.	Fabr.	Byggeår	Merknad	Vogn nr.	Fabr.	Byggeår	Merknad
10914	LH	20		10957	FMV	23	
10915	"	"		10958	"	"	
10916	"	"		10959	"	"	
10917	"	"		10960	"	"	
10918	"	"		10961	"	"	
10919	"	"		10962	"	"	
10920	"	"		10963	"	"	
10921	"	"		10964	"	"	
10922	"	"		10965	"	24	
10923	"	"		10966	"	"	
			H-tegn. 1458 + 2278	10967	"	"	
10924	LH	21		10968	"	"	
10925	"	"		10969	"	"	
10926	"	"		10970	"	"	
10927	"	"		10971	"	"	
10928	"	"		10972	"	"	
10929	"	"		10973	"	"	
10930	"	"		10974	"	"	
10931	"	"					H-tegn. 1458 + 2140
10932	"	"		10975	FMV	25	
10933	"	"		10976	"	"	
10940	FMV	23		10977	"	"	
10941	"	"		10978	"	"	
10942	"	"		10979	"	"	
10943	"	"		10980	"	"	
10944	"	"		10982	"	"	
10945	"	"		10983	"	"	
10946	"	"		10984	"	"	
10947	"	"		10985	"	"	
10948	"	"		10986	"	"	
10949	"	"		10987	"	"	
10950	"	"		10988	"	"	
10951	"	"		10989	"	"	
10952	"	"		10990	"	"	
10954	"	"		10991	"	"	
10955	"	"		10992	"	"	
10956	"	"		10993	"	"	

Vogn nr.	Fabr.	Byggår	Merknad	Vogn nr.	Fabr.	Byggår	Merknad
10994	FMV	25		14563	Str	16	
10995	"	"		14564	"	"	
14529	Str	16		14565	"	"	
14530	"	"		14566	"	"	
14531	"	"		14567	"	"	
14532	"	"		14568	"	"	
14533	"	"					H-tegn. 1458 + 2278
14534	"	"		14569	FMV	24	
14535	"	"		14570	"	"	
14536	"	"		14571	"	"	
14537	"	"		14572	"	"	
14538	"	"		14573	"	"	
14539	"	"		14574	"	"	
14540	"	"		14575	"	"	
14541	"	"		14576	"	"	
14542	"	"		14577	"	"	
14543	"	"		14578	"	"	
14544	"	"					H-tegn. 1458 + 2140
14545	"	"		15536	Str	16	
14546	"	"		15537	"	"	
14547	"	"		15538	"	"	
14548	"	"		15539	"	"	
14549	"	"		15540	"	"	
14550	"	"		15541	"	"	
14551	"	"		15542	"	"	
14552	"	"		15543	"	"	
14553	"	"		15544	"	"	
14554	"	"		15545	"	"	
14555	"	"		15546	"	22	
14556	"	"		15547	"	"	
14557	"	"		15548	"	"	
14558	"	"		15549	"	"	
14559	"	"		15550	"	"	
14560	"	"		15551	"	"	
14561	"	"		15552	"	"	
14562	"	"	1)	15553	"	"	
				15554	"	"	

1) Höye endelemmer.

Vogn nr.	Fabr.	Byggeår	Merknad	Vogn nr.	Fabr.	Byggeår	Merknad
15555	Str	22		15590	FMV	25	
15556	"	"		15591	"	"	
15557	"	"		15592	"	"	
15558	"	"		15593	"	"	
15559	"	"		15594	"	"	
15560	"	"		15595	"	"	
15561	"	"		15596	"	"	
15562	"	"		15597	"	"	
15563	"	"		15598	"	"	
15564	"	"		15599	"	"	
15565	"	"		15600	"	"	
15566	"	"		16475	Edf	"	
15567	"	"		16476	"	"	
15568	"	"		16477	"	"	
15569	"	"		16478	"	"	
15570	"	"		16479	"	"	
15571	FMV	25		16480	"	"	
15572	"	"		16481	"	"	
15573	"	"		16482	"	"	
15574	"	"		16483	"	"	
15575	"	"		16484	"	"	
15576	"	"					H-tegn. 1458 + 2278
15577	"	"		16485	FMV	25	
15578	"	"		16486	"	"	
15579	"	"		16487	"	"	
15580	"	"		16488	"	"	
15581	"	"		16489	"	"	
15582	"	"		16490	"	"	
15583	"	"		16491	"	"	
15584	"	"		16492	"	"	
15585	"	"		16493	"	26	
15586	"	"		16494	"	"	
15587	"	"					H-tegn. 1458 + 2140
15588	"	"		16516	Str	27	
15589	"	"		16517	"	"	

T13
TYPE 1

Vogn nr.	Fabr.	Byggeår	Merknad	Vogn nr.	Fabr.	Byggeår
16518	Str	27		16568	Str	28
V-16519	"	"		16569	"	"
16520	"	"		16570	"	"
16521	"	"		17026	Skb	19
V-16522	"	"		17027	"	"
16523	"	"		17028	"	"
16524	"	"		17029	"	"
16525	"	"		17031	"	"
V-16526	"	"		17032	"	"
16527	"	"		17033	"	"
16528	"	"		17034	"	"
16529	"	21		17035	"	"
16530	"	"		V-17136	LH	21
16531	"	"		V-17137	"	"
V-16532	"	"		17139	"	"
V-16533	"	"		17140	"	"
V-16534	"	"		V-17141	"	"
16535	"	"		17142	"	"
V-16536	"	"		17143	"	"
16537	"	"		17144	"	"
V-16538	"	"		17146	"	"
16539	"	"		17147	"	"
V-16540	"	"		V-17148	"	"
16541	"	"		17149	"	"
16542	"	"		17150	"	"
16543	"	"		17159	"	"
V-16544	"	"		17160	"	"
16545	"	"		17161	"	"
16546	"	"		17162	"	"
16547	"	"		17163	"	"
V-16548	"	"				
16549	"	"				
16550	"	"				
16566	"	"				
16567	"	"				

T14

TYPE 1

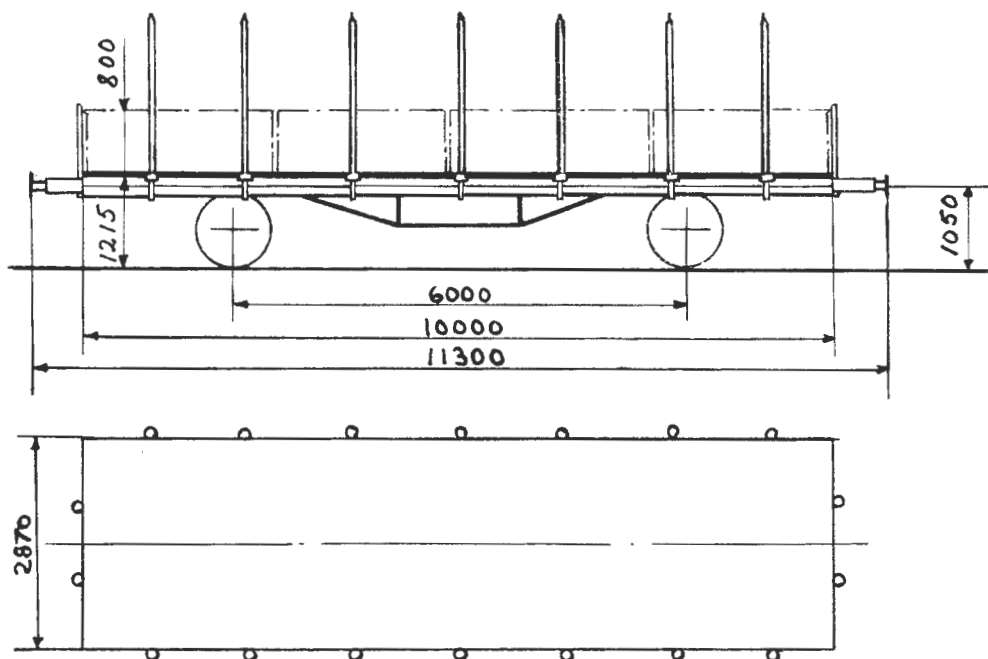

Omtrentlig vognvekt 8,5-11,0 t
 " bæreevne 19,5-20,5 t
 Gulvflate 28,7 m²
 Rominnhold 22,8-23,0 m³
 Hovedtegning 3770 + 4066, 3770 +
 4350 eller 8141

PLATTFORMVOGN MED NEDLEGBARE JERNLEMMER

Vogn nr.	Fabr.	Byggeår	Merknad	Vogn nr.	Fabr.	Byggeår	Merknad
60206	Skb	36	H-tegn. 3770 + 4066	60220	Skb	37	
60207	"	"		60221	"	"	
60208	"	"		60222	"	"	
60209	"	"		60223	"	"	
60210	"	"		60224	"	"	
60211	"	"		60225	"	"	
60212	"	"		60226	"	"	
60213	"	"		60227	"	"	
60214	"	"		60228	"	"	
60215	"	"		60229	"	"	
60216	"	37		60230	"	"	
60217	"	"		60231	"	"	
60218	"	"		60232	"	"	
60219	"	"		60233	"	"	
				60234	"	"	

T14
TYPE 1

Vogn nr.	Fabr.	Byggear	Merknad	Vogn nr.	Fabr.	Byggear	Merknad
60235	Skb	37		60270	Skb	38	
60236	"	"		60271	"	"	
60237	"	"		60272	"	"	
60238	"	"		60273	"	"	
60239	"	"		60274	"	"	
60240	"	"		60275	"	"	
60241	"	"		60276	"	"	
60242	"	"		60277	"	"	
60243	"	"		60278	"	"	
60244	"	"		60279	"	"	
60245	"	"		60280	"	"	
60246	"	"		60281	"	"	
60247	"	"		60282	"	"	
60248	"	"		60283	"	"	
60249	"	"		60284	"	"	
60250	"	"		60285	"	"	
60251	"	"		60286	"	39	
60252	"	"		60287	"	"	
60253	"	"		60288	"	"	
60254	"	"		60289	"	"	
60255	"	"		60290	"	"	
			H-tegn. 3770 + 4350	60291	"	"	
60256	Skb	38		60292	"	"	
60257	"	"		60293	"	"	
60258	"	"		60294	"	"	
60259	"	"		60295	"	"	
60260	"	"		60296	"	38	
60261	"	"		60297	"	"	
60262	"	"		60298	"	"	
60263	"	"		60299	"	"	
60264	"	"		60300	"	"	1)
60265	"	"		60301	"	"	
60267	"	"		60302	"	"	
60268	"	"		60303	"	"	
60269	"	"					

1) Har utstyr for transport av trefiberplater.

Trykk nr. 752 1.1.68

Vogn nr.	Fabr.	Byggeår	Merknad	Vogn nr.	Fabr.	Byggeår	Merknad
60304	Skb	38		60339	Skb	40	
60305	"	"		60340	"	"	
60306	"	39		60341	"	"	
60307	"	"		60342	"	"	
60308	"	"		60343	"	"	
60309	"	"		60344	"	"	
60310	"	"		60345	"	"	
60311	"	"		60346	"	"	
60312	"	"		60347	"	"	
60313	"	"		60348	"	"	
60314	"	"		60349	"	"	
60315	"	"		60350	"	"	
60316	"	"		60351	"	"	
60317	"	"		60352	"	"	
60318	"	"		60353	"	"	
60319	"	"		60354	"	"	
60320	"	"		60355	"	"	
60321	"	"		60356	"	"	
60322	"	"		60357	"	"	
60323	"	"		60358	"	"	
60324	"	"		60359	"	"	1)
60325	"	"		60360	"	"	
60326	"	"		60361	"	"	
60327	"	"		60362	"	"	
60328	"	"		60363	"	"	
60329	"	"		60364	"	"	
60330	"	"		60365	"	"	
60331	"	"		60366	"	"	
60332	"	"		60367	"	"	
60333	"	"		60368	"	"	
60334	"	40		60369	"	"	
60335	"	"		60370	"	"	
60336	"	"		60371	"	"	
60337	"	"		60372	"	"	
60338	"	"		60373	"	"	

1) Har utstyr for transport av trefiberplater.

T14
TYPE 1

Vogn nr.	Fabr.	Byggeår	Merknad	Vogn nr.	Fabr.	Byggeår	Merknad
60374	Skb	40		60409	Edf	40	
60375	"	"		60410	"	"	
60376	"	39		60411	"	"	
60377	"	"		60413	"	"	
60378	"	"		60414	"	"	
60379	"	"		60415	"	"	
60380	"	"		60496	Skb	42	
60381	"	"		60497	"	"	
60382	"	"		60498	"	"	
60383	"	"		60499	"	"	
60384	"	"		60500	"	"	
60385	"	"		60501	"	"	
60386	Edf	40		60502	"	"	
60387	"	"		60503	"	"	
60388	"	"		60504	"	"	
60389	"	"		60505	"	"	
60390	"	"		60506	"	"	
60391	"	"		60507	"	"	
60392	"	"		60508	"	"	
60393	"	"		60509	"	"	
60394	"	"		60510	"	"	
60395	"	"		60511	"	"	
60396	"	"		60512	"	"	
60397	"	"		60513	"	"	
60398	"	"		60514	"	"	
60399	"	"		60515	"	"	
60400	"	"		60516	"	"	
60401	"	"		60517	"	"	
60402	"	"		60518	"	"	
60403	"	"		60519	"	"	
60404	"	"		60520	"	"	
60405	"	"		60521	"	"	
60406	"	"		60522	"	"	
60407	"	"		60523	"	"	
60408	"	"		60524	"	"	

Vogn nr.	Fabr.	Byggeår	Merknad	Vogn nr.	Fabr.	Byggeår	Merknad
60525	Skb	42		60560	Skb	46	
60526	"	"		60561	"	"	
60527	"	"		60562	"	"	
60528	"	"		60563	"	"	
60529	"	"		60564	"	"	
60530	"	"		60565	"	"	
60531	"	"		60566	"	"	
60532	"	"		60567	"	"	
60533	"	"		60568	"	"	
60534	"	"		60569	"	"	
60535	"	"		60570	"	"	
60536	"	"		60571	"	"	
60537	"	"		60572	"	"	
60538	"	"		60573	"	"	
60539	"	"		60574	"	"	
60540	"	"		60575	"	"	
60541	"	"		60576	"	"	
60542	"	"		60577	"	"	
60543	"	"		60578	"	"	
60544	"	"		60579	"	"	
60545	"	"		60580	"	"	
60546	"	45		60581	"	"	
60547	"	"		60583	"	"	
60548	"	"		60584	"	"	
60549	"	46		60585	"	"	
60550	"	"		60586	"	"	
60551	"	"		60587	"	"	
60552	"	"		60588	"	"	
60553	"	45		60589	"	"	
60554	"	"		60590	"	"	
60555	"	"		60591	"	"	
60556	"	46		60592	"	"	
60557	"	"		60593	"	"	
60558	"	"		60594	"	"	
60559	"	"					

T14
TYPE 1

Vogn nr.	Fabr.	Byggeår	Merknad	Vogn nr.	Fabr.	Byggeår	Merknad
60595	Skb	46		60629	Str	44	
60596	"	"		60630	"	"	
60597	"	"		60631	"	"	
60598	"	"		60632	"	"	
60599	"	"		60633	"	"	
60600	"	"		60634	"	"	1)
60601	"	"		60635	"	"	
60602	"	"		60636	"	"	
60603	"	"		60637	"	"	
60604	"	"		60638	"	"	
60605	"	"		60639	"	"	
60606	"	"		60640	"	"	
60607	"	"		60641	"	"	
60608	"	"		60642	"	"	
60609	"	"		60643	"	"	
60610	"	"		60644	"	"	
60611	"	"		60645	"	"	
60612	"	"		60646	"	"	
60613	"	"		60647	"	"	
60614	"	"		60648	"	"	
60615	"	"		60649	"	"	
60616	"	"		60650	"	"	
60617	"	"		60651	"	"	
60618	"	"		60652	"	"	
60619	"	"		60653	"	"	
60620	"	"		60654	"	"	
60621	Str	44		60655	"	"	
60622	"	"		60656	"	"	
60623	"	"		60657	"	"	
60624	"	"		60658	"	"	
60625	"	"		60659	"	"	
60626	"	"		60660	"	"	
60627	"	"		60661	"	"	
60628	"	"		60662	"	"	
				60663	"	"	

1) Har utstyr for transport av trefiberplater.

Vogn nr.	Fabr.	Byggear	Merknad	Vogn nr.	Fabr.	Byggear	Merknad
50664	Str	44		60700	Skb	46	
60665	"	"		60701	"	"	
60666	"	"		60702	"	"	
60667	"	"		60703	"	"	
60668	"	"		60704	"	"	
60669	"	"		60705	"	"	
60670	"	"		60706	"	"	
60671	"	"		60707	"	"	
60672	"	"		60708	"	"	
60673	"	"		60709	"	47	
60674	"	"		60710	"	"	
60675	"	"		60711	"	"	
60676	"	"		60712	"	"	
60677	"	"		60713	"	"	
60678	"	"		60714	"	"	
60679	"	"		60715	"	"	
60680	"	"		60716	"	"	
60681	"	"		60717	"	"	
60682	"	"		60718	"	"	
60683	"	"		60719	"	"	
60684	"	"		60720	"	"	
60685	"	"		60721	"	"	
60686	"	"		60722	"	"	
60687	"	"		60723	"	"	
60688	"	"		60724	"	"	
60689	"	"		60725	"	"	
60690	Str	45		60726	"	"	
60691	"	"		60727	"	"	
60692	"	"		60728	"	"	
60693	"	"		60729	"	"	
60694	"	"		60730	"	"	
60695	"	"		60731	"	"	
60696	Skb	46		60732	"	"	
60697	"	"		60733	"	"	
60698	"	"		60734	"	"	
60699	"	"					

T14
TYPE 1

Vogn nr.	Fabr.	Byggeår	Merknad	Vogn nr.	Fabr.	Byggeår	Merknad
60736	Skb	47		60771	Str	47	
60737	"	"		60772	"	"	
60738	"	"		60773	"	48	
60739	"	"		60774	"	"	
60740	"	"		60775	"	"	
60741	"	"		60776	"	"	
60742	"	"		60777	"	"	
60743	"	"		60778	"	"	
60744	"	"		60779	"	"	
60745	"	"		60780	"	"	
60746	"	"		60781	"	"	
60747	"	"		60782	"	"	
60748	"	"		60783	"	"	
60749	"	"		60784	"	"	
60750	"	"		60785	"	"	
60751	"	"		60786	"	"	
60752	"	"		60787	"	"	
60753	"	"		60788	"	"	
60754	"	"		60789	"	"	
60755	"	"		60790	"	"	
60756	"	"		60791	"	"	
60757	"	"		60792	"	"	
60758	"	"		60793	"	"	
60759	"	"		60794	"	"	
60760	"	"		60795	"	"	
60761	"	"		60796	"	"	
60762	"	"		60797	"	"	
60763	"	"		60798	"	"	
60764	"	"		60799	"	"	
60765	"	"		60800	"	"	
60766	Str	"		60801	"	"	
60767	"	"		60802	"	"	
60768	"	"		60803	"	"	
60769	"	"		60804	"	"	
60770	"	"		60805	"	"	

Vogn nr.	Fabr.	Byggeår	Merknad	Vogn nr.	Fabr.	Byggeår	Merknad
60806	Str	48		60842	Str	50	
60807	"	"		60843	"	"	
60808	"	"		60844	"	"	
60809	"	"		60845	"	"	
60810	"	"		60846	"	"	1)
60811	"	"		60847	"	"	
60812	"	"		60848	"	"	
60813	"	"		60849	"	"	
60814	"	"		60850	"	"	
60815	"	"		60851	"	"	
60816	"	"		60852	"	"	
60817	"	"		60854	"	"	
60818	"	"		60855	"	"	
60819	"	"		60856	"	"	
60820	"	"		60857	"	"	
60821	"	"		60858	"	"	
60822	"	"		60859	"	"	
60823	"	"		60860	"	"	
60824	"	"		60861	"	"	
60825	"	"		60862	"	"	
60826	"	"		60863	"	"	
60827	"	"		60864	"	"	
60828	"	"		60865	"	"	
60829	"	"		60866	"	"	
60830	"	"		60867	"	"	
60831	"	"		60868	"	"	
60832	"	"		60869	"	"	
60833	"	"		60870	"	"	
60834	"	"		60871	"	"	
60835	"	"		60872	"	"	
60836	"	"		60873	"	"	
60837	"	"		60874	"	"	
60838	"	"		60875	"	"	
60839	"	"		60876	"	"	
60840	"	"		60877	"	"	
60841	"	"					

1) Har utstyr for transport av trefiberplater.

Vogn nr.	Fabr.	Byggear	Merknad	Vogn nr.	Fabr.	Byggear	Merknad
60878	Str	50		60913	Str	52	
60879	"	"		60914	"	51	
60880	"	"		60915	"	52	
60881	"	"		60916	"	"	
60882	"	"		60917	"	"	
60883	"	"		60918	"	"	
60884	"	"		60919	"	"	
60885	"	"		60920	"	"	
60886	"	"		60921	"	"	
60887	"	"		60922	"	"	
60888	"	51		60923	"	"	
60889	"	"		60924	"	"	
60890	"	"		60925	"	"	
60891	"	"		60926	"	"	
60892	"	"		60927	"	"	
60893	"	"		60928	"	"	
60894	"	"		60929	"	"	
60895	"	"		60930	"	"	
60896	"	"		60931	"	"	
60897	"	"		60932	"	"	
60898	"	"		60933	"	"	
60899	"	"		60934	"	"	
60900	"	"		60935	"	"	
60901	"	"		60936	"	"	
60902	"	"		60937	"	"	
60903	"	"		60938	"	"	
60904	"	"		60939	"	"	
60905	"	"		60940	"	"	
60906	"	"		60941	Edf	50	
60907	"	"		60942	"	"	
60908	"	"		60943	"	"	
60909	"	"		60944	"	"	
60910	"	"		60945	"	"	
60911	"	"		60946	"	"	
60912	"	"		60947	"	"	

Vogn nr.	Fabr.	Byggeår	Merknad	Vogn nr.	Fabr.	Byggeår	Merknad
60948	Edf	50		60983	Edf	50	
60949	"	"		60984	"	"	
60950	"	"		60985	"	"	
60951	"	"		60986	"	"	
60952	"	"		60987	"	"	
60953	"	"		60988	"	"	
60954	"	"		60989	"	"	
60955	"	"		60990	"	"	
60956	"	"		60991	"	"	
60957	"	"		60992	"	"	
60958	"	"		60993	"	"	
60959	"	"		60994	"	"	
60960	"	"		60995	"	"	
60961	"	"		60996	"	"	
60962	"	"		60997	"	"	
60963	"	"		60998	"	"	
60964	"	"		60999	"	"	
60965	"	"		61000	"	"	
60966	"	"		61001	"	"	
60967	"	"		61002	"	"	
60968	"	"		61003	"	"	
60969	"	"		61004	"	"	
60970	"	"		61005	"	"	
60971	"	"		61006	"	"	
60972	"	"		61007	"	"	
60973	"	"		61008	"	"	
60974	"	"		61009	"	"	
60975	"	"		61010	"	"	
60976	"	"		61011	"	"	
60977	"	"		61012	"	"	
60978	"	"		61013	"	"	
60979	"	"		61014	"	"	
60980	"	"		61015	"	"	
60981	"	"		61016	"	"	
60982	"	"					

Vogn nr.	Fabr.	Byggeår	Merknad	Vogn nr.	Fabr.	Byggeår	Merknad
61017	Edf	50		61052	Edf	50	
61018	"	"		61053	"	"	
61019	"	"		61054	"	"	
61020	"	"		61055	"	"	
61021	"	"		61056	"	"	
61022	"	"		61057	"	"	
61023	"	"		61058	"	"	
61024	"	"		61059	"	"	
61025	"	"		61060	"	"	
61026	"	"		61061	"	51	
61027	"	"		61062	"	"	
61028	"	"		61063	"	"	
61029	"	"		61064	"	"	
61030	"	"		61065	"	"	
61031	"	"		61066	Str	52	
61032	"	"		61067	"	"	
61033	"	"		61068	"	"	
61034	"	"		61069	"	"	
61035	"	"		61070	"	"	
61036	"	"		61071	"	"	
61037	"	"		61072	"	"	
61038	"	"		61073	"	"	
61039	"	"		61074	"	"	
61040	"	"		61075	"	"	
61041	"	"		61076	"	"	
61042	"	"		61077	"	"	
61043	"	"		61078	"	"	
61044	"	"		61079	"	"	
61045	"	"		61080	"	"	
61046	"	"		61081	"	"	
61047	"	"		61082	"	"	
61048	"	"		61083	"	"	
61049	"	"		61084	"	"	
61050	"	"		61085	"	"	
61051	"	"		61086	"	"	

Vogn nr.	Fabr.	Byggeår	Merknad	Vogn nr.	Fabr.	Byggeår	Merknad
61087	Str	52		61122	Str	52	
61088	"	"		61123	"	"	
61089	"	"		61124	"	"	
61090	"	"		61125	"	"	
61091	"	"		61126	"	"	
61092	"	"		61127	"	"	
61093	"	"		61128	"	"	
61094	"	"		61129	"	"	
61095	"	"		61130	"	"	
61096	"	"		61131	"	"	
61097	"	"		61132	"	"	
61098	"	"		61133	"	"	
61099	"	"		61134	"	"	
61100	"	"		61135	"	53	
61101	"	"		61136	"	"	
61102	"	"		61137	"	"	
61103	"	"		61138	"	"	
61104	"	"		61139	"	"	
61105	"	"		61140	"	"	
61106	"	"		61141	"	"	
61107	"	"		61142	"	"	
61108	"	"		61143	"	"	
61109	"	"		61144	"	"	
61110	"	"		61145	"	"	
61111	"	"		61146	"	"	
61112	"	"		61147	"	"	
61113	"	"		61148	"	"	
61114	"	"		61149	"	"	
61115	"	"		61150	"	"	
61116	"	"		61151	"	"	
61117	"	"		61152	"	"	
61118	"	"		61153	"	"	
61119	"	"		61154	"	"	
61120	"	"		61155	"	"	
61121	"	"		61156	"	"	

Vogn nr.	Fabr.	Byggear	Merknad	Vogn nr.	Fabr.	Byggear	Merknad
61157	Str	53		61192	Edf	54	
61158	"	"		61193	"	"	
61159	"	"		61194	"	"	
61160	"	"		61195	"	"	
61161	"	"		61196	"	"	
61162	"	"		61197	"	"	2)
61163	"	"		61198	"	"	
61164	"	"		61199	"	"	
61165	"	"		61200	"	"	
61166	"	"		61201	"	"	
61167	"	"		61202	"	"	
61168	"	"		61203	"	"	
61169	"	"		61204	"	"	
61170	"	"		61205	"	"	
61171	"	"		61206	"	"	2)
61172	"	"		61207	"	"	
61173	"	"		61208	"	"	
61174	"	"		61209	"	"	
61175	"	"		61210	"	"	
61176	"	"		61211	"	"	
61177	"	"		61212	"	"	
61178	"	"		61213	"	"	
61179	"	"		61214	"	"	
61180	"	"		61215	"	"	
61181	"	"		61216	"	"	
61182	"	"		61217	"	"	2)
61183	"	"		61218	"	"	
61184	"	"		61219	"	"	
61185	"	"		61220	"	"	5)
61186	"	"		61221	"	"	
61187	"	"		61222	"	"	2)
61188	"	"		61223	"	"	2)
61189	"	"	1)	61224	"	"	
61190	"	"		61225	"	"	
61191	Edf	54		61226	"	"	

1) Utstyr for transport av trefiberplater. 2) Midlertidig utstyrt med skinner for transport av beholdere. 5) Utstyrt for transport av beholdere for lössement.

Vogn nr.	Fabr.	Byggeår	Merknad	Vogn nr.	Fabr.	Byggeår	Merknad
61227	Edf	54		61262	Hök	54	
61228	"	"		61263	"	"	
61229	"	"	3)	61264	"	"	
61230	"	"		61265	"	"	2)
61231	Hök	"		61266	"	"	
61232	"	"		61267	"	"	
61233	"	"		61268	"	"	
61234	"	"		61269	"	"	
61235	"	"		61270	"	"	
61236	"	"					H-tegn. 8141
61237	"	"		61271	Mbg	60	
61238	"	"		61272	"	"	
61239	"	"	3)	61273	"	"	
61240	"	"		61274	"	"	
61241	"	"		61275	"	"	
61242	"	"		61276	"	"	
61243	"	"		61277	"	"	
61244	"	"		61278	"	"	
61245	"	"		61279	"	"	
61246	"	"	3)	61280	"	"	
61247	"	"		61281	"	"	
61248	"	"		61282	"	"	
61249	"	"		61283	"	"	
61250	"	"	5)	61284	"	"	
61251	"	"		61285	"	"	
61252	"	"	2)	61286	"	"	
61253	"	"		61287	"	"	
61254	"	"		61288	"	"	
61255	"	"		61289	"	"	
61256	"	"		61290	"	"	
61257	"	"	4)	61291	"	"	
61258	"	"		61292	"	"	
61259	"	"		61293	"	"	
61260	"	"		61294	"	"	
61261	"	"		61295	"	"	

2) Midlertidig utstyrt med skinner for transport av beholdere. 3) Elektrisk varmekabel og transformator (1000/220 V) for margarinoljetransport. 4) Utstyr for transport av beholdere type LC-40. 5) Utstyrt for transport av beholdere for lössement.

Vogn nr.	Fabr.	Byggear	Merknad	Vogn nr.	Fabr.	Byggear	Merknad
61296	Mbg	60		61331	Mbg	61	
61297	"	"		61332	"	"	
61298	"	"		61333	"	"	
61299	"	"		61334	"	"	
61300	"	"		61335	"	"	
61301	"	"		61336	"	"	
61302	"	"		61337	"	"	
61303	"	"		61338	"	"	
61304	"	"		61339	"	"	
61305	"	"		61340	"	"	
61306	"	"		61341	"	62	
61307	"	"		61342	"	"	
61308	"	"		61343	"	"	
61309	"	"		61344	"	"	
61310	"	"		61345	"	"	
61311	"	"		61346	"	"	
61312	"	"		61347	"	"	4)
61313	"	"		61348	"	"	
61314	"	"		61349	"	"	
61315	"	"		61350	"	"	
61316	"	"		61351	"	"	
61317	"	"		61352	"	"	
61318	"	"		61353	"	"	
61319	"	"		61354	"	"	
61320	"	"		61355	"	"	
61321	"	61		61356	"	"	
61322	"	"		61357	"	"	
61323	"	"		61358	"	"	
61324	"	"		61359	"	"	
61325	"	"		61360	"	"	
61326	"	"		61361	"	"	
61327	"	"		61362	"	"	
61328	"	"		61363	"	"	
61329	"	"		61364	"	"	
61330	"	"		61365	"	"	

4) Utstyr for transport av beholdere type LC-40.

Vogn nr.	Fabr.	Byggeår	Merknad	Vogn nr.	Fabr.	Byggeår	Merknad
61366	Mbg	62					
61367	"	"					
61368	"	"					
61369	"	"					
61370	"	"					

T14 type 1-vogner med internasjonal litrering og nummerering.

Vogn nr.	Fabr.	Byggeår	Merknad	Vogn nr.	Fabr.	Byggeår	Merknad
21 76 361 0010-9	Skb	37		21 76 361 0272-5	Skb	46	
361 0050-5	"	38		361 0280-8	"	"	
361 0051-3	"	"		361 0288-1	"	"	
361 0067-9	"	"		361 0296-4	"	"	
361 0095-0	"	39		361 0299-8	"	"	
361 0116-4	"	40		361 0307-9	"	"	
361 0118-0	"	"		361 0312-9	Str	44	
361 0119-8	"	"		361 0329-3	"	"	
361 0121-4	"	"		361 0333-5	"	"	
361 0128-9	"	"		361 0345-9	"	"	
361 0133-9	"	"		361 0360-8	"	"	
361 0134-7	"	"		361 0368-1	Skb	47	
361 0135-4	"	"		361 0378-0	"	46	
361 0136-2	"	"		361 0379-8	"	"	
361 0146+1	"	"		361 0385-5	"	47	
361 0151-1	"	39		361 0388-9	"	"	
361 0158-6	"	"		361 0402-8	"	"	
361 0166-9	Edf	40		361 0429-1	"	"	
361 0171-9	"	"		361 0434-1	"	"	
361 0177-6	"	"		361 0438-2	Str	"	
361 0178-4	"	"		361 0439-0	"	"	
361 0182-6	"	"		361 0443-2	"	"	
361 0183-4	"	"		361 0445-7	"	48	
361 0190-9	Skb	42		361 0447-3	"	"	
361 0196-6	"	"		361 0455-6	"	"	
361 0198-2	"	"		361 0458-0	"	"	
361 0201-4	"	"		361 0460-6	"	"	
361 0208-9	"	"		361 0466-3	"	"	
361 0218-8	"	"		361 0478-8	"	"	
361 0219-6	"	"		361 0492-9	"	"	
361 0224-6	"	"		361 0503-3	"	"	
361 0232-9	"	"		361 0505-8	"	"	
361 0240-2	"	45		361 0519-9	"	50	
361 0261-8	"	46		361 0527-2	"	"	
361 0271-7	"	"		361 0537-1	"	"	

T14 type 1-vogner med internasjonal litrering og nummerering.

Vogn nr.	Fabr.	Byggeår	Merknad	Vogn nr.	Fabr.	Byggeår	Merknad
21 76 361 0538-9	Str	50		21 76 361 0695-7	Edf	50	
361 0540-5	"	"		361 0698-1	"	"	
361 0545-4	"	"		361 0705-4	"	"	
361 0546-2	"	"		361 0709-6	"	"	
361 0547-0	"	"		361 0712-0	"	"	
361 0550-4	"	"		361 0713-8	"	"	
361 0553-8	"	"		361 0714-6	"	"	
361 0559-5	"	51		361 0715-3	"	"	
361 0562-9	"	"		361 0722-9	"	51	
361 0564-5	"	"		361 0726-0	Str	52	
361 0572-8	"	"		361 0732-8	"	"	
361 0578-5	"	"		361 0751-8	"	"	
361 0586-8	"	52		361 0770-8	"	"	
361 0588-4	"	"		361 0774-0	"	"	
361 0596-7	"	"		361 0778-1	"	"	
361 0611-4	Edf	50		361 0807-8	"	53	
361 0619-7	"	"		361 0810-2	"	"	
361 0622-1	"	"		361 0840-9	Edf	54	
361 0625-4	"	"		361 0886-2	Hök	"	
361 0633-8	"	"		361 0889-6	"	"	
361 0635-3	"	"		361 0897-9	"	"	
361 0642-9	"	"		361 0899-5	"	"	
361 0643-7	"	"		361 0901-9	"	"	
361 0645-2	"	"		361 0928-2	Mbg	60	
361 0653-6	"	"		361 0952-2	"	61	
361 0656-9	"	"					
361 0667-6	"	"					
361 0669-2	"	"					
361 0671-8	"	"					
361 0673-4	"	"					
361 0678-3	"	"					
361 0681-7	"	"					
361 0689-0	"	"					
361 0691-6	"	"					
361 0693-2	"	"					

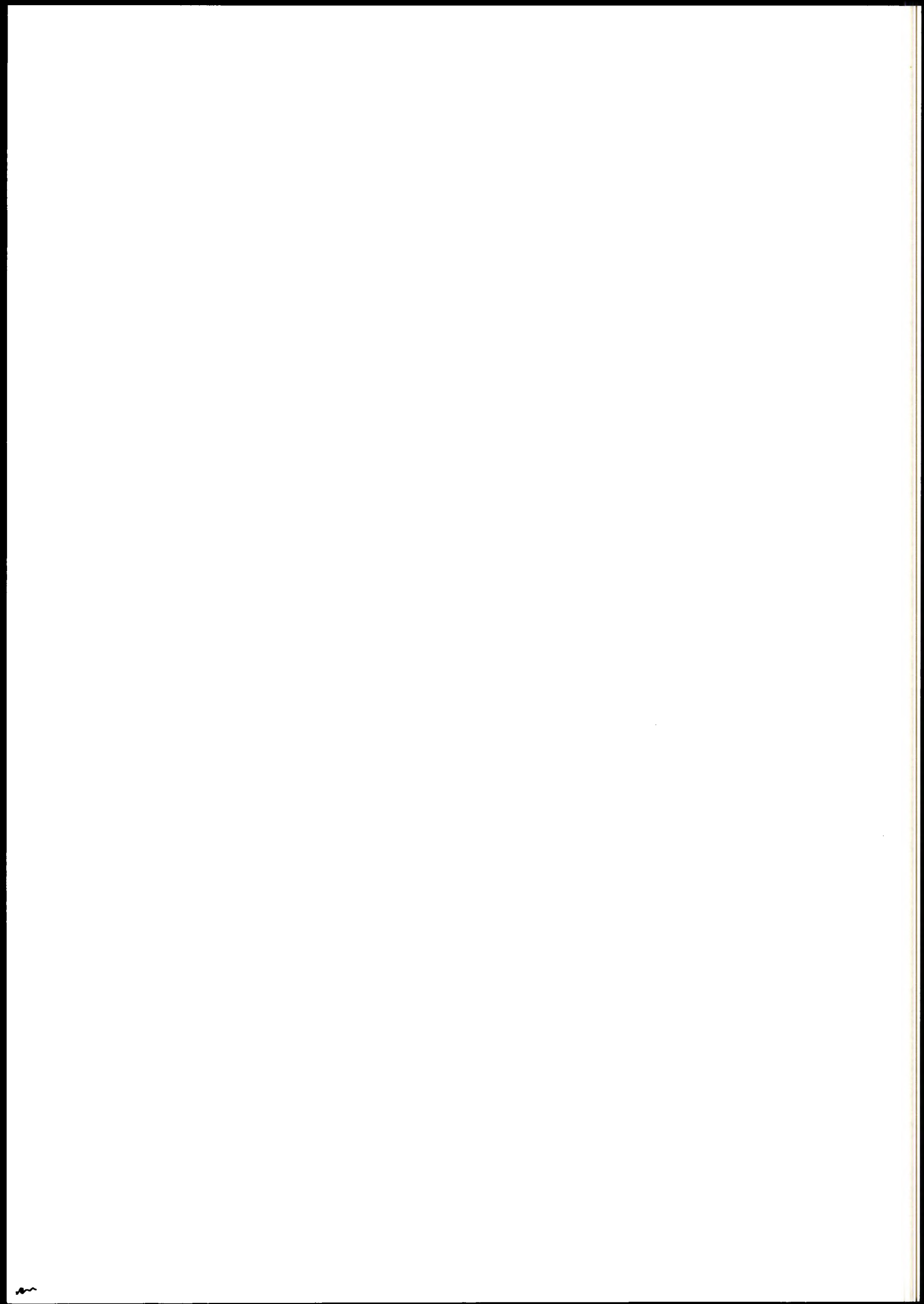

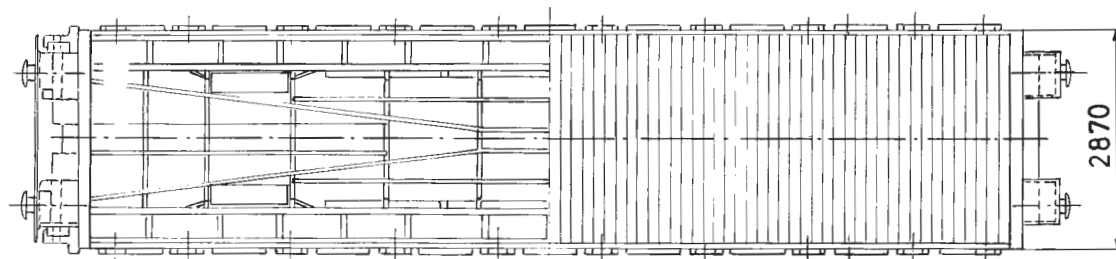
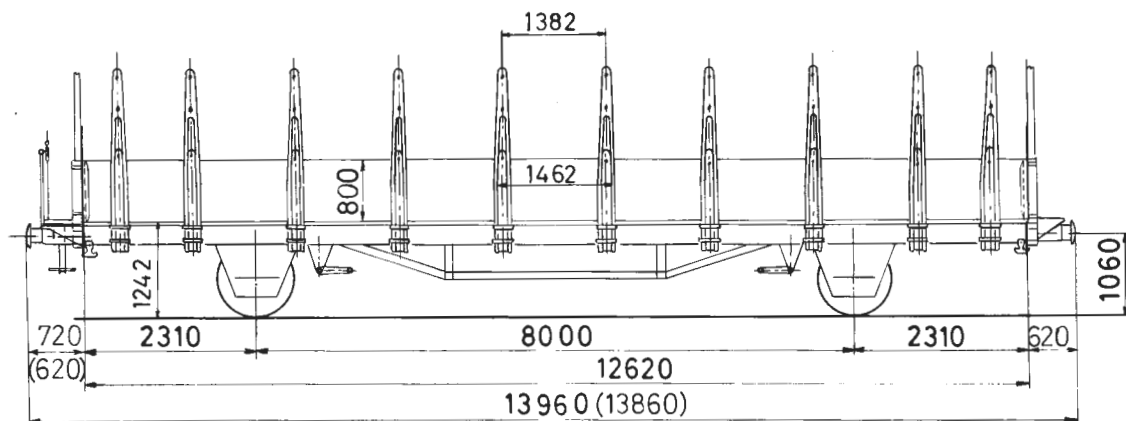

Bæreevne

	A	B	C
	19,0t	23,0t	27,0t
S	19,0t	23,0t	

F.o.m. vg.nr. 370 0470:

Bæreevne

	A	B	C
	18,5t	22,5t	26,5t
S	18,5t	22,5t	

Omtrentlig vognvekt 13,0-13,5t

Gulvflate 36,0m²Rominnhold 29,0m³

Hovedtegning se fotnote

PLATTFORMVOGN MED NEDLEGGBARE JERNLEMNER

Vogn nr.	Fabr.	Byggeår	Merknad	Vogn nr.	Fabr.	Byggeår	Merknad
62000	Stv	62		62014	Stv	63	
62001	"	63		62015	"	"	
62002	"	"		62016	"	"	
62003	"	"		62017	"	"	
62004	"	"		62018	"	"	
62005	"	"		62019	"	"	
62006	"	"		62020	"	"	
62007	"	"		62021	"	"	
62008	"	"		62022	"	"	
62009	"	"		62023	"	"	
62010	"	"		62024	"	"	
62011	"	"		62025	"	"	
62012	"	"		62026	"	"	
62013	"	"		62027	"	"	

Hovedtegning 10165: Vg.nr. 62000-62199

" 12297 " " 62200-62399

" 14450: F.o.m. vg.nr. 62400. Har ratt for skrubremse på siden. Mål i () gjelder disse vg.

Trykk nr. 752 1.1.68

Vogn nr.	Fabr.	Byggear	Merknad	Vogn nr.	Fabr.	Byggear	Merknad
62028	Stv	63		62063	Stv	63	
62029	"	"		62064	"	"	
62030	"	"		62065	"	"	
62031	"	"		62066	"	"	
62032	"	"		62067	"	"	
62033	"	"		62068	"	"	
62034	"	"		62069	"	"	
62035	"	"		62070	"	"	
62036	"	"		62071	"	"	
62037	"	"		62072	"	"	
62038	"	"		62073	"	"	
62039	"	"		62074	"	"	
62040	"	"		62075	"	"	
62041	"	"		62076	"	"	
62042	"	"		62077	"	"	
62043	"	"		62078	"	"	
62044	"	"		62079	"	"	
62045	"	"		62080	"	"	
62046	"	"		62081	"	"	
62047	"	"		62082	"	"	
62048	"	"		62083	"	"	
62049	"	"		62084	"	"	
62050	"	"		62085	"	"	
62051	"	"		62086	"	"	
62052	"	"		62087	"	"	
62053	"	"		62088	"	"	
62054	"	"		62089	"	"	
62055	"	"		62090	"	"	1)
62056	"	"		62091	"	"	
62057	"	"		62092	"	"	
62058	"	"		62093	"	"	
62059	"	"		62094	"	"	
62060	"	"		62095	"	"	
62061	"	"		62096	"	"	
62062	"	"		62097	"	"	

1) Stålgulv. Vognvekt: 14,0 t. Bæreevne, A: 18,0 t, B: 22,0 t, C: 26,0 t. Som S-vogn, A: 18,0 t, BC: 22,0 t.

Vogn nr.	Fabr.	Byggear	Merknad	Vogn nr.	Fabr.	Byggear	Merknad
62098	Stv	63		62133	Stv	64	
62099	"	"		62134	"	"	
62100	"	"		62135	"	"	2)
62101	"	"		62136	"	"	
62102	"	"		62137	"	"	
62103	"	"		62138	"	"	
62104	"	"		62139	"	"	
62105	"	"		62140	"	"	
62106	"	"		62141	"	"	
62107	"	64		62142	"	"	
62108	"	63		62143	"	"	
62109	"	"		62144	"	"	
62110	"	"		62145	"	"	
62111	"	"		62146	"	"	
62112	"	64		62147	"	"	
62113	"	"		62148	"	"	
62114	"	"		62149	"	"	
62115	"	"		62150	"	"	
62116	"	"		62151	"	"	
62117	"	"		62152	"	"	
62118	"	"		62153	"	"	
62119	"	"		62154	"	"	
62120	"	"		62155	"	"	
62121	"	"		62156	"	"	
62122	"	"		62157	"	"	
62123	"	"		62158	"	"	
62124	"	"		62159	"	"	
62125	"	"		62160	"	"	
62126	"	"		62161	"	"	
62127	"	"		62162	"	"	
62128	"	"		62163	"	"	
62129	"	"		62164	"	"	
62130	"	"		62165	"	"	
62131	"	"		62166	"	"	
62132	"	"		62167	"	"	

2) Utstyr for trailertransport.

T15
TYPE 1

Vogn nr.	Fabr.	Byggear	Merknad	Vogn nr.	Fabr.	Byggear	Merknad
62168	Stv	64		62203	Stv	64	
62169	"	"		62204	"	"	
62170	"	"		62205	"	"	
62171	"	"		62206	"	"	
62172	"	"		62207	"	"	
62173	"	"		62208	"	"	
62174	"	"		62209	"	"	
62175	"	"		62210	"	"	
62176	"	"		62211	"	"	
62177	"	"		62212	"	"	
62178	"	"		62213	"	"	
62179	"	"		62214	"	"	
62180	"	"		62215	"	"	
62181	"	"		62216	"	"	
62182	"	"		62217	"	"	
62183	"	"		62218	"	"	
62184	"	"		62219	"	"	
62185	"	"		62220	"	"	
82186	"	"		62221	"	"	
62187	"	"		62222	"	"	
62188	"	"		62223	"	"	
62189	"	"		62224	"	"	
62190	"	"		62225	"	"	
62191	"	"		62226	"	"	
62192	"	"		62227	"	"	
62193	"	"		62228	"	"	
62194	"	"		62229	"	"	
62195	"	"		62230	"	"	
62196	"	"		62231	"	"	
62197	"	"		62232	"	"	
62198	"	"		62233	"	"	
62199	"	"		62234	"	"	
62200	"	"		62235	"	"	
62201	"	"		62236	"	"	
62202	"	"		62237	"	"	

T15 type 1-vogner med internasjonal litrering og nummerering.

Vogn nr.	Fabr.	Byggeår	Merknad	Vogn nr.	Fabr.	Byggeår	Merknad
21 76 370 0000-1	Stv	62		21 76 370 0050-6	Stv	63	
370 0001-9	"	63		370 0052-2	"	"	
370 0002-7	"	"		370 0053-0	"	"	
370 0004-3	"	"		370 0054-8	"	"	
370 0005-0	"	"		370 0055-5	"	"	
370 0006-8	"	"		370 0056-3	"	"	
370 0010-0	"	"		370 0057-1	"	"	
370 0015-9	"	"		370 0058-9	"	"	
370 0016-7	"	"		370 0059-7	"	"	
370 0017-5	"	"		370 0061-3	"	"	
370 0019-1	"	"		370 0062-1	"	"	
370 0020-9	"	"		370 0063-9	"	"	
370 0021-7	"	"		370 0067-0	"	"	
370 0023-3	"	"		370 0068-8	"	"	
370 0024-1	"	"		370 0069-6	"	"	
370 0025-8	"	"		370 0071-2	"	"	
370 0026-6	"	"		370 0072-0	"	"	
370 0027-4	"	"		370 0073-8	"	"	
370 0028-2	"	"		370 0074-6	"	"	
370 0029-0	"	"		370 0075-3	"	"	
370 0030-8	"	"		370 0076-1	"	"	
370 0031-6	"	"		370 0077-9	"	"	
370 0032-4	"	"		370 0078-7	"	"	
370 0033-2	"	"		370 0079-5	"	"	
370 0034-0	"	"		370 0081-1	"	"	
370 0035-7	"	"		370 0083-7	"	"	
370 0038-1	"	"		370 0084-5	"	"	
370 0039-9	"	"		370 0085-2	"	"	
370 0040-7	"	"		370 0087-8	"	"	
370 0043-1	"	"		370 0090-2	"	"	1)
370 0044-9	"	"		370 0095-1	"	"	
370 0045-6	"	"		370 0096-9	"	"	
370 0047-2	"	"		370 0101-7	"	"	
370 0048-0	"	"		370 0470-6	"	66	2)
370 0049-8	"	"		370 0471-4	"	"	2)

1) Stålgulv. V.v.: 14,0 t. Bæreevne A: 18,0 t, B: 22,0 t, C: 26,0 t. Som S-vogn, A: 18,0 t, BC: 22,0 t. 2) Strammeanordning for last.

T15 type 1-vogner med internasjonal litrering og nummerering.

Vogn nr.	Fabr.	Byggeår	Merknad	Vogn nr.	Fabr.	Byggeår	Merknad
21 76 370 0472-2	Stv	66	2)	21 76 370 0508-3	Stv	66	2)
370 0473-0	"	"	2)	370 0509-1	"	"	2)
370 0474-8	"	"	2)	370 0510-9	"	"	2)
370 0475-5	"	"	2)	370 0511-7	"	"	2)
370 0476-3	"	"	2)	370 0512-5	"	"	2)
370 0477-1	"	"	2)	370 0513-3	"	"	2)
370 0478-9	"	"	2)	370 0514-1	"	"	2)
370 0479-7	"	"	2)	370 0515-8	"	"	2)
370 0481-3	"	"	2)	370 0516-6	"	"	2)
370 0482-1	"	"	2)	370 0517-4	"	"	2)
370 0483-9	"	"	2)	370 0518-2	"	"	2)
370 0484-7	"	"	2)	370 0519-0	"	"	2)
370 0485-4	"	"	2)	370 0520-8	"	"	2)
370 0486-2	"	"	2)	370 0521-6	"	"	2)
370 0487-0	"	"	2)	370 0522-4	"	"	2)
370 0488-8	"	"	2)	370 0523-2	"	"	2)
370 0489-6	"	"	2)	370 0524-0	"	"	2)
370 0490-4	"	"	2)	370 0525-7	"	"	2)
370 0491-2	"	"	2)	370 0526-5	"	"	2)
370 0492-0	"	"	2)	370 0527-3	"	"	2)
370 0493-8	"	"	2)	370 0528-1	"	"	2)
370 0494-6	"	"	2)	370 0529-9	"	"	2)
370 0495-3	"	"	2)	370 0530-7	"	"	2)
370 0496-1	"	"	2)	370 0532-3	"	"	2)
370 0497-9	"	"	2)	370 0533-1	"	"	2)
370 0498-7	"	"	2)	370 0534-9	"	"	2)
370 0499-5	"	"	2)	370 0535-6	"	"	2)
370 0500-0	"	"	2)	370 0536-4	"	"	2)
370 0501-8	"	"	2)	370 0537-2	"	"	2)
370 0502-6	"	"	2)	370 0538-0	"	"	2)
370 0503-4	"	"	2)	370 0539-8	"	"	2)
370 0504-2	"	"	2)	370 0540-6	"	"	2)
370 0505-9	"	"	2)	370 0541-4	"	"	2)
370 0506-7	"	"	2)	370 0542-2	"	"	2)
370 0507-5	"	"	2)	370 0543-0	"	"	2)

2) Strammeanordning for last.

T15 type 1-vogner med internasjonal litrering og nummerering.

Vogn nr.	Fabr.	Byggeår	Merknad	Vogn nr.	Fabr.	Byggeår	Merknad
21 76 370 0544-8	Stv	66	2)	21 76 370 0580-2	Stv	66	2)
370 0545-5	"	"	2)	370 0581-0	"	"	2)
370 0546-3	"	"	2)	370 0582-8	"	"	2)
370 0547-1	"	"	2)	370 0583-6	"	"	2)
370 0549-7	"	"	2)	370 0584-4	"	"	2)
370 0550-5	"	"	2)	370 0585-1	"	"	2)
370 0551-3	"	"	2)	370 0586-9	"	"	2)
370 0552-1	"	"	2)	370 0587-8	"	"	2)
370 0553-9	"	"	2)	370 0588-5	"	"	2)
370 0554-7	"	"	2)	370 0589-3	"	"	2)
370 0555-4	"	"	2)	370 0590-1	"	"	2)
370 0556-2	"	"	2)	370 0591-9	"	"	2)
370 0557-0	"	"	2)	370 0592-7	"	"	2)
370 0558-8	"	"	2)	370 0593-5	"	"	2)
370 0559-6	"	"	2)	370 0594-3	"	"	2)
370 0560-4	"	"	2)	370 0595-0	"	"	2)
370 0561-2	"	"	2)	370 0596-8	"	"	2)
370 0562-0	"	"	2)	370 0597-6	"	"	2)
370 0563-8	"	"	2)	370 0598-4	"	"	2)
370 0564-6	"	"	2)	370 0599-2	"	"	2)
370 0565-3	"	"	2)	370 0600-8	"	"	2)
370 0566-1	"	"	2)	370 0601-6	"	67	2)
370 0567-9	"	"	2)	370 0602-4	"	66	2)
370 0568-7	"	"	2)	370 0603-2	"	"	2)
370 0569-5	"	"	2)	370 0604-0	"	"	2)
370 0570-3	"	"	2)	370 0605-7	"	"	2)
370 0571-1	"	"	2)	370 0606-5	"	"	2)
370 0572-9	"	"	2)	370 0607-3	"	67	2)
370 0573-7	"	"	2)	370 0608-1	"	"	2)
370 0574-5	"	"	2)	370 0609-9	"	66	2)
370 0575-2	"	"	2)	370 0610-7	"	67	2)
370 0576-0	"	"	2)	370 0611-5	"	"	2)
370 0577-8	"	"	2)	370 0612-3	"	66	2)
370 0578-6	"	"	2)	370 0613-1	"	"	2)
370 0579-4	"	"	2)	370 0614-9	"	"	2)

2) Strammeanordning for last.

T15 type 1-vogner med internasjonal litrering og nummerering.

Vogn nr.	Fabr.	Byggear	Merknad	Vogn nr.	Fabr.	Byggear	Merknad
21 76 370 0615-6	Stv	66	2)	21 76 370 0650-3	Stv	67	2) 3)
370 0616-4	"	67	2)	370 0651-1	"	"	2) 3)
370 0617-2	"	66	2)	370 0652-9	"	"	2) 3)
370 0618-0	"	67	2)	370 0653-7	"	"	2) 3)
370 0619-8	"	"	2)	370 0654-5	"	"	2) 3)
370 0620-6	"	"	2)	370 0655-2	"	"	2) 3)
370 0621-4	"	"	2)	370 0656-0	"	"	2)
370 0622-2	"	"	2)	370 0657-8	"	"	2)
370 0623-0	"	"	2)	370 0658-6	"	"	2)
370 0624-8	"	"	2)	370 0659-4	"	"	2)
370 0625-5	"	"	2)	370 0660-2	"	"	2)
370 0626-3	"	"	2) 3)	370 0661-0	"	"	2)
370 0627-1	"	"	2) 3)	370 0662-8	"	"	2)
370 0628-9	"	"	2) 3)	370 0663-6	"	"	2)
370 0629-7	"	"	2) 3)	370 0664-4	"	"	2)
370 0630-5	"	"	2) 3)	370 0665-1	"	"	2)
370 0631-3	"	"	2) 3)	370 0666-9	"	"	2)
370 0632-1	"	"	2) 3)	370 0667-7	"	"	2)
370 0633-9	"	"	2) 3)	370 0668-5	"	"	2)
370 0634-7	"	"	2) 3)	370 0669-3	"	"	2)
370 0635-4	"	"	2) 3)	370 0670-1	"	"	2)
370 0636-2	"	"	2) 3)	370 0671-9	"	"	2)
370 0637-0	"	"	2) 3)	370 0672-7	"	"	2)
370 0638-8	"	"	2) 3)	370 0673-5	"	"	2)
370 0639-6	"	"	2) 3)	370 0674-3	"	"	2)
370 0640-4	"	"	2) 3)	370 0675-0	"	"	2)
370 0641-2	"	"	2) 3)	370 0676-8	"	"	2)
370 0642-0	"	"	2) 3)	370 0677-6	"	"	2)
370 0643-8	"	"	2) 3)	370 0678-4	"	"	2)
370 0644-6	"	"	2) 3)	370 0679-2	"	"	2)
370 0645-3	"	"	2) 3)	370 0680-0	"	"	2)
370 0646-1	"	"	2) 3)	370 0681-8	"	"	2)
370 0647-9	"	"	2) 3)	370 0682-6	"	"	2)
370 0648-7	"	"	2) 3)	370 0683-4	"	"	2)
370 0649-5	"	"	2) 3)	370 0684-2	"	"	2)

2) Strammeanordning for last. 3) Fast tømmertransport. Side- og endelemmer, endestaker og hjørnestendere samt RIV-mrk. midlertidig sløyfet. Påmalt bæreevne økt. Vognnr. endres ikke.

T15 type 1-vogner med internasjonal litrering og nummerering.

Vogn nr.	Fabr.	Byggeår	Merknad	Vogn nr.	Fabr.	Byggeår	Merknad
21 76 370 0685-9	Stv	67	2)	21 76 370 0720-4	Stv	67	5)
370 0686-7	"	"	2)	370 0721-2	"	"	2)
370 0687-5	"	"	2)	370 0722-0	"	"	2)
370 0688-3	"	"	2)	370 0723-8	"	"	2)
370 0689-1	"	"	2)	370 0724-6	"	"	2)
370 0690-9	"	"	2)	370 0725-3	"	"	2)
370 0691-7	"	"	4)	370 0726-1	"	"	2)
370 0692-5	"	"	4)	370 0727-9	"	"	2)
370 0693-3	"	"	4)	370 0728-7	"	"	2)
370 0694-1	"	"	2)	370 0729-5	"	"	2)
370 0695-8	"	"	2)	370 0730-3	"	"	2)
370 0696-6	"	"	2)	370 0731-1	"	"	2)
370 0697-4	"	"	2)	370 0732-9	"	"	2)
370 0698-2	"	"	2)	370 0733-7	"	"	2)
370 0699-0	"	"	2)	370 0734-5	"	"	2)
370 0700-6	"	"	2)	370 0735-2	"	"	2)
370 0701-4	"	"	5)	370 0736-0	"	"	2)
370 0702-2	"	"	5)	370 0737-8	"	"	2)
370 0703-0	"	"	5)	370 0738-6	"	"	2)
370 0704-8	"	"	5)	370 0739-4	"	"	2)
370 0705-5	"	"	5)	370 0740-2	"	"	2)
370 0706-3	"	"	5)	370 0741-0	"	"	2)
370 0707-1	"	"	5)	370 0742-8	"	"	2)
370 0708-9	"	"	5)	370 0743-6	"	"	2)
370 0709-7	"	"	5)	370 0744-4	"	"	2)
370 0710-5	"	"	5)	370 0745-1	"	"	2)
370 0711-3	"	"	5)	370 0746-9	"	"	2)
370 0712-1	"	"	5)	370 0747-7	"	"	2)
370 0713-9	"	"	5)	370 0748-5	"	"	2)
370 0714-7	"	"	5)	370 0749-3	"	"	2)
370 0715-4	"	"	5)	370 0750-1	"	"	2)
370 0716-2	"	"	5)	370 0751-9	"	"	2)
370 0717-0	"	"	5)	370 0752-7	"	"	2)
370 0718-8	"	"	5)	370 0753-5	"	"	2)
370 0719-6	"	"	5)	370 0754-3	"	"	2)

2) Strammeanordning for last. 4) Påmont. låsanordn. for transport av salpetersyre. Har ikke lemmer, staker og strammeanordn. Bæreevne A: 20,0 t, B: 24,0 t, C: 28,0 t. Som S-vogn A: 20,0 t, BC: 24,0 t. 5) Påmont. låsanordn. for transport av containere. Har ikke lemmer, staker og strammeanordn. Bæreevne A: 20,0 t, B: 24,0 t, C: 28,0 t. Som S-vogn A: 20,0 t, BC: 24,0 t.

T15 type 1-vogner med internasjonal litrering og nummerering.

Vogn nr.	Fabr.	Byggeår	Merknad	Vogn nr.	Fabr.	Byggeår	Merknad
21 76 370 0755-0	Stv	67	2)				
370 0756-8	"	"	2)				
370 0757-6	"	"	2)				
370 0758-4	"	"	2)				
370 0759-2	"	"	2)				
370 0760-0	"	"	2)				
370 0761-8	"	"	2)				
370 0762-6	"	"	2)				
370 0763-4	"	"	2)				
370 0764-2	"	"	2)				
370 0765-9	"	"	2)				
370 0766-7	"	"	2)				
370 0767-5	"	"	2)				
370 0768-3	"	"	2)				
370 0769-1	"	"	2)				
370 0770-9	"	"	2)				
370 0771-7	"	"	2)				
370 0772-5	"	"	2)				
370 0773-3	"	"	2)				
370 0774-1	"	"	2)				
370 0775-8	"	"	2)				
370 0776-6	"	"	2)				
370 0777-4	"	"	2)				
370 0778-2	"	"	2)				
370 0779-0	"	"	2)				

2) Strammeanordning for last.

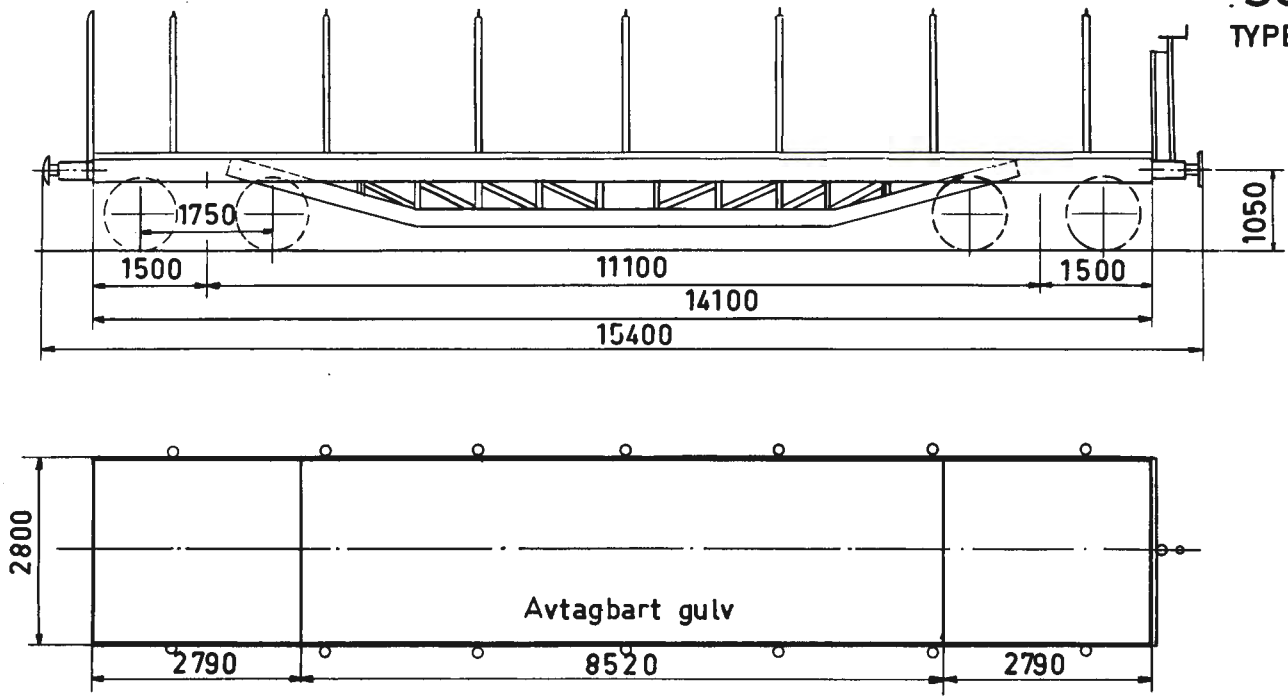

Omtrentlig vognvekt 17,0-17,5 t
 " bæreevne 30,0-31,5 t
 Gulvflate 395 m²
 Hovedtegning 2302

SPESIAL PLATTFORMVOGN

Vogn nr.	Fabr.	Byggeår	Merknad	Vogn nr.	Fabr.	Byggeår	Merknad
5405	Skb	21					
10934	Str	22					
15994	"	23					

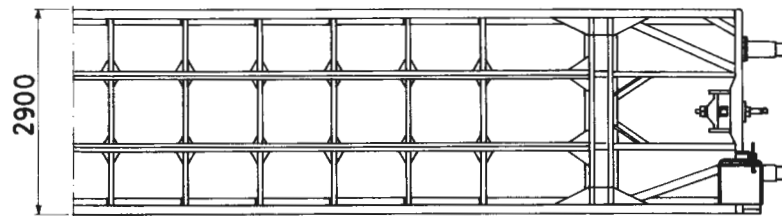
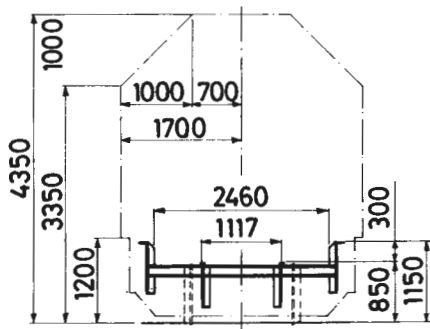
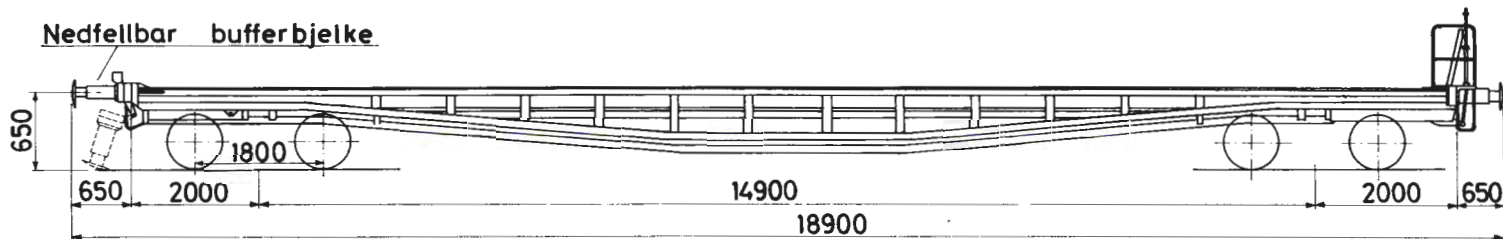

Bæreevne

A	B	C
42,0 t		

Omtrentlig vognvekt 18,0 t¹⁾
Hovedtegning 3931¹⁾

Spesial plattformvogn

Vogn nr.	Fabr.	Byggeår	Merknad	Vogn nr.	Fabr.	Byggeår	Merknad
20850	Str	36					

¹⁾ Ved konsentrerte laster se litografert tegning.

Tsfo3

TYPE 1

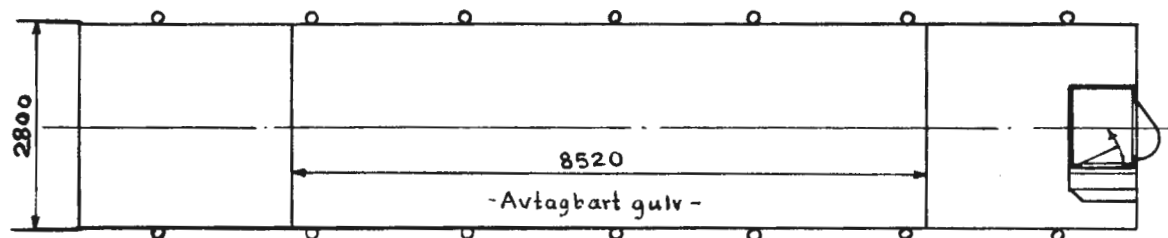
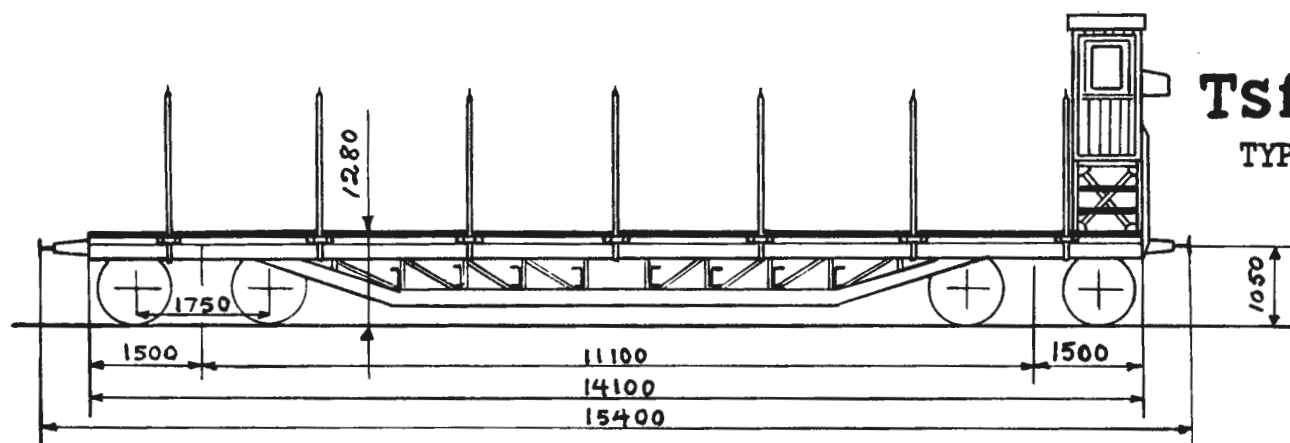

Höyde fra skinnetopp til overkant av tverrbjelke (for last når gulvet er fjernet) = 315 mm. (Ved bufferhöyde = 1050 mm).

Omtrentlig vognvekt	17,5 t
" bæreevne	30,0 t
Gulvflate	39,5 m ²
Rominhold	-
Hovedtegning	2302

SPECIAL PLATTFORMVOGN

Vogn nr.	Fabr.	Byggeår	Merknad	Vogn nr.	Fabr.	Byggeår	Merknad
5406	Str	22					
15995	"	23					

U 4
TYPE 1

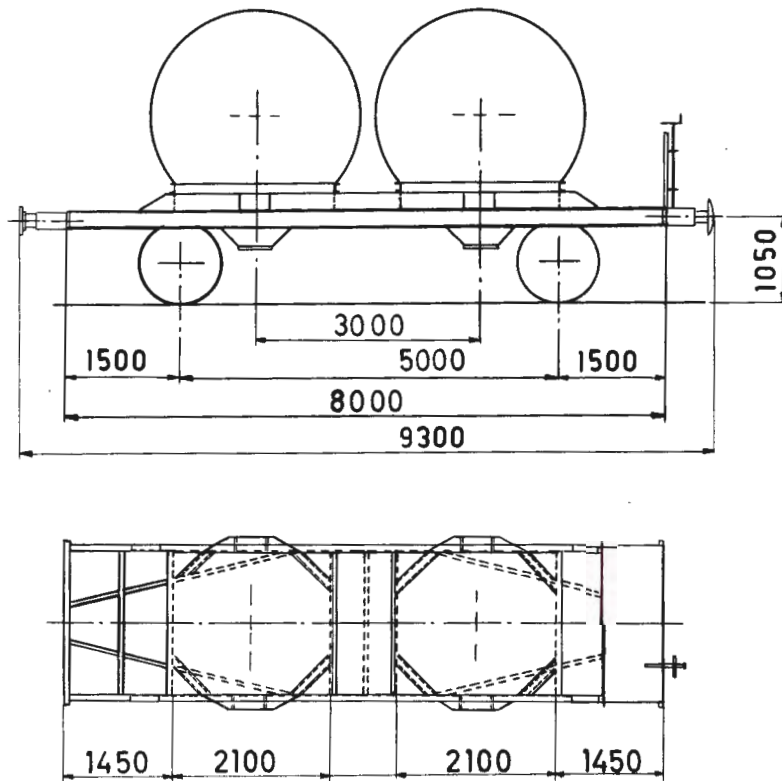

Bæreevne

A	B	C
21,0t	21,0t	

Omtrentlig vognvekt 9,0 t
 Gulvflate —
 Rominnhold 22,6 m
 Hovedtegning 8679
 +10095

SEMENTTRANSPORTVOGN

Vogn nr.	Fabr.	Byggeår	Merknad	Vogn nr.	Fabr.	Byggeår	Merknad
75000	Edf	37					
75001	"	46					
75002	"	47					
75003	"	46					

U4
TYPE 2

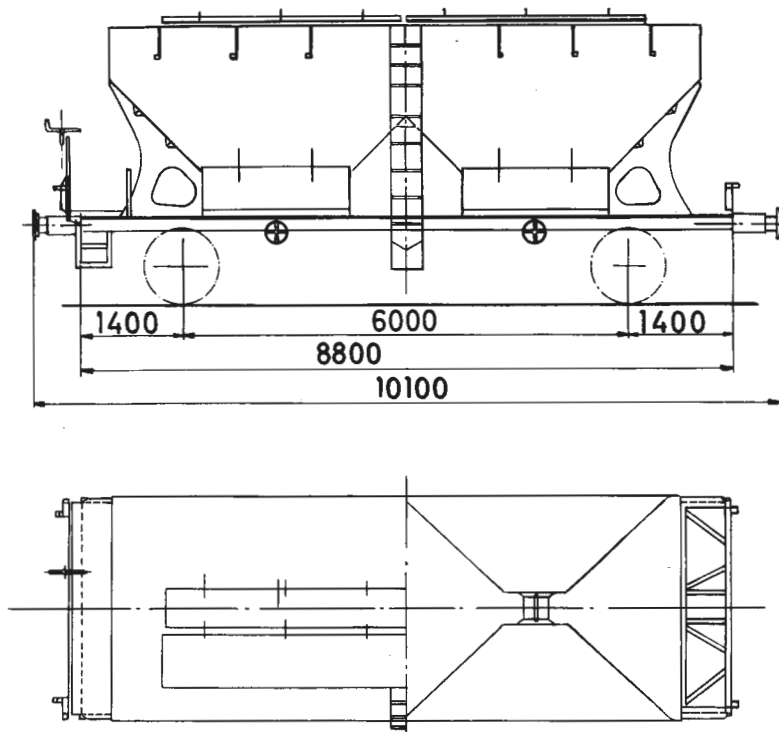

Omtrentlig vognvekt 11,0-12,0t
 " bærevne 18,5-19,0t
 Rominnhold 31,0 m³
 Hovedtegning 8496

KORNTRANSPORTVOGN

Vogn nr.	Fabr.	Byggeår	Merknad	Vogn nr.	Fabr.	Byggeår	Merknad
75100	1)	41		75115	3)	42	
75101	"	"		75116	"	"	
75102	"	"		75117	"	"	
75103	"	"		75118	"	"	
75104	"	42		75119	"	41	
75105	"	41		75120	"	43	
75106	2)	40		75121	"	41	
75107	"	41		75122	5)	43	
75108	"	"		75123	"	"	
75109	"	42		75124	"	"	
75110	"	41		75125	"	42	
75111	"	"		75126	"	41	
75112	"	42		75127	"	42	
75113	3) 4)			75128	"	41	
75114	"	42		75129	"	"	

1) Omb. i Drmi 1960. 2) Omb. i Drm i 1961. 3) Omb. i Drm i 1962.

4) Oppr. byggeår ukjent. 5) Omb. i Drm i 1963.

Trykk nr. 752 1.1.68

Udgk

U4 type 2-vogner med internasjonal litrering og nummerering.

Vogn nr.	Fabr.	Byggeår	Merknad	Vogn nr.	Fabr.	Byggeår	Merknad
21 76 907 9004-3	1)	42					
907 9005-0	"	41					

1) Ombygd i Drm 1960.

U5
TYPE 1

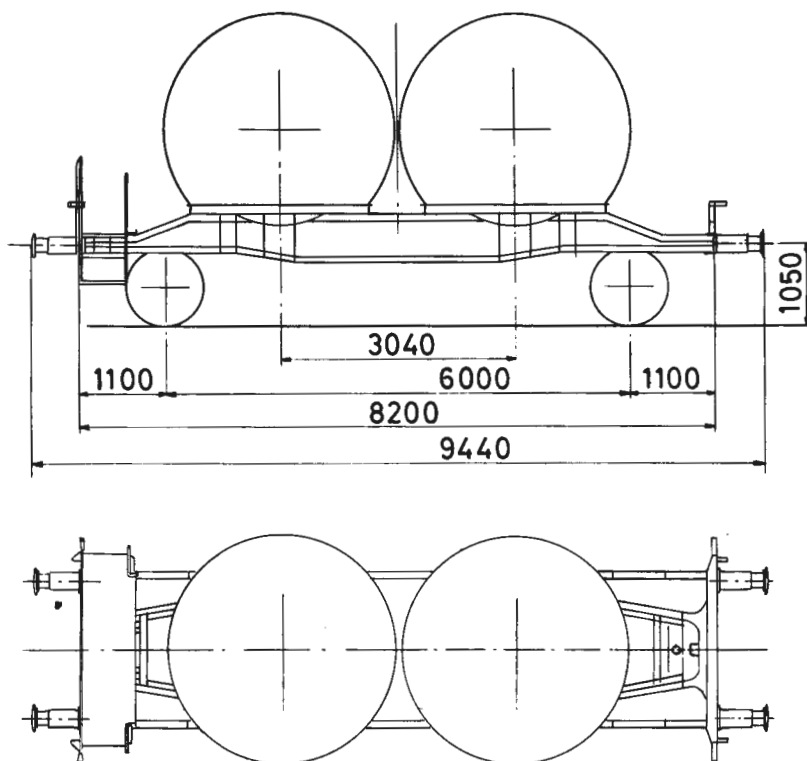

Bæreevne

A	B	C
21,0t	25,0t	29,0t

Omtrentlig vognvekt 11,0t
 Gulvflate -
 Rominnhold 28,0m³
 Hovedtegning 11485

SEMMENTTRANSPORTVOGN

Vogn nr.	Fabr.	Byggeår	Merknad	Vogn nr.	Fabr.	Byggeår	Merknad
75004	Grd	62					
75005	"	"					
75006	"	"					
75007	"	"					

Uac

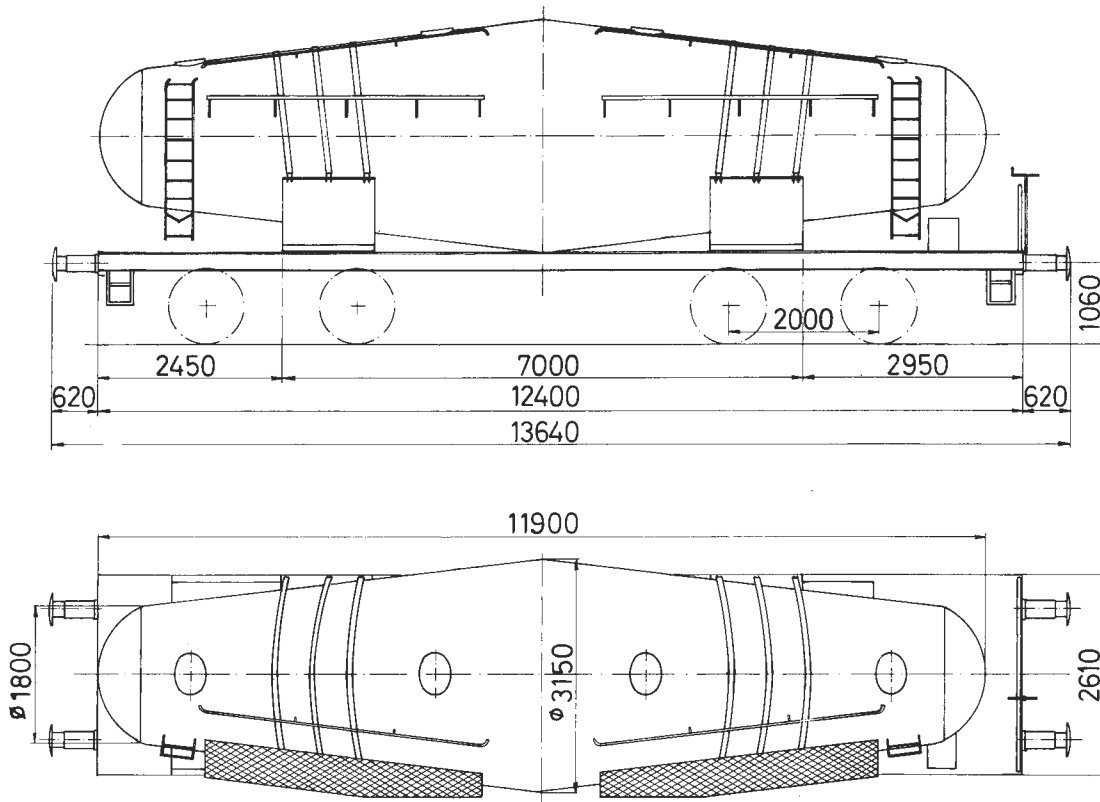

Bæreevne

A	B	C
42,0 t	50,0 t	58,0 t

Omtrentlig vognvekt 21,0 t

Rominnhold 46,0 m³

Hovedtegning Vst. Drm., D1-320

KALKMELTRANSPORTVOGN

Vogn nr.	Fabr.	Byggeår	Merknad	Vogn nr.	Fabr.	Byggeår	Merknad
21 76 920 5000-8	Sun	66					

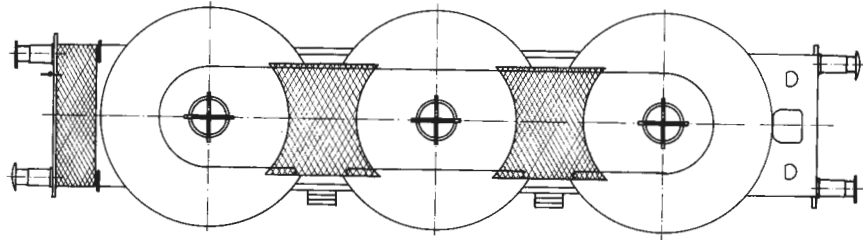
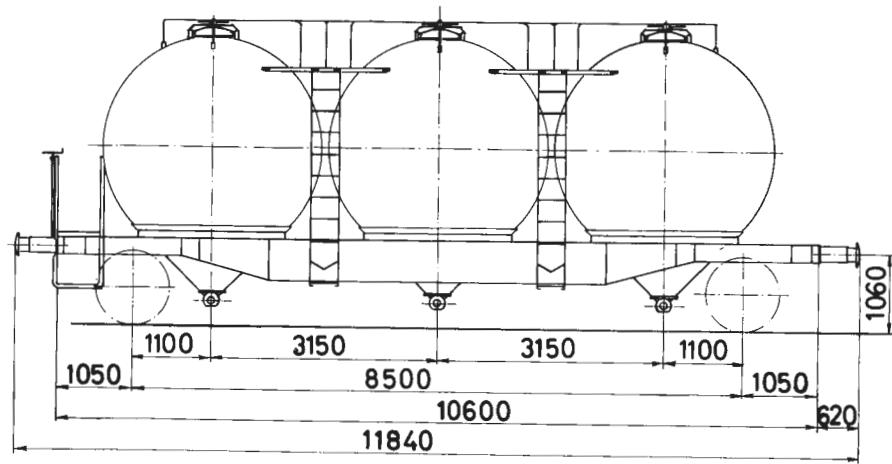

Bæreevne		
A	B	C
20,0t	24,0 t	
S	20,0t	24,0 t

Omtrentlig vognvekt	12,5t
Gulvflate	-
Rominnhold	48,0 m ³
Hovedtedteging	14449

PULVERTRANSPORTVOGN

Vogn nr.	Fabr.	Byggeår	Merknad	Vogn nr.	Fabr.	Byggeår	Merknad
21 76 910 5000-9	Chr	64	1)				
910 5001-7	"	"	1)				
910 5002-5	Sun	65					
910 5003-3	"	66					
910 5004-1	"	"					

1) Hovedteging 13711

Ucs
Type 2

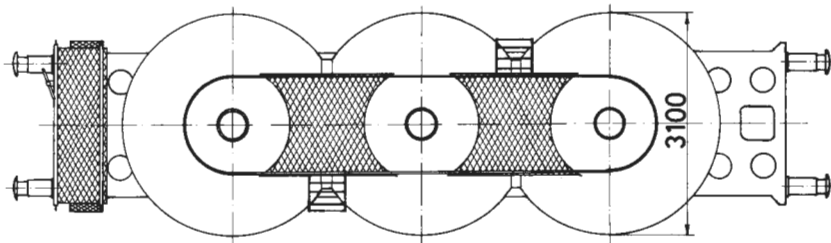
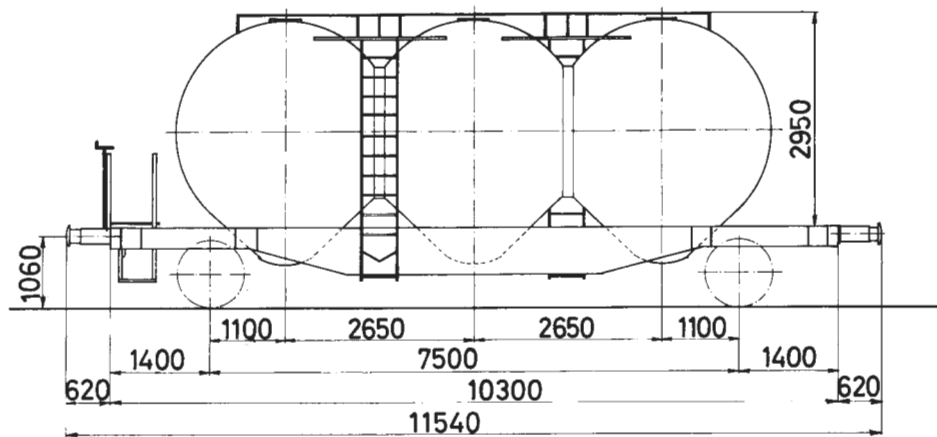

Bæreevne

	A	B	C
	20,0t	24,0t	27,5t
S	20,0t	24,0t	

Omtrentlig vognvekt 12,0t

Rominnhold 47,0m³

Hovedtegning 19268

PULVERTRANSPORTVOGN

Vogn nr.	Fabr.	Byggeår	Merknad	Vogn nr.	Fabr.	Byggeår	Merknad
21 76 910 5005-8	Chr	67					
910 5006-6	"	"					
910 5007-4	"	"					
910 5008-2	"	"					
910 5009-0	"	"					
910 5010-8	"	"					
910 5011-6	"	"					
910 5012-4	"	"					
910 5013-2	"	"					
910 5014-0	"	"					

Trykk nr 752 1.1.68

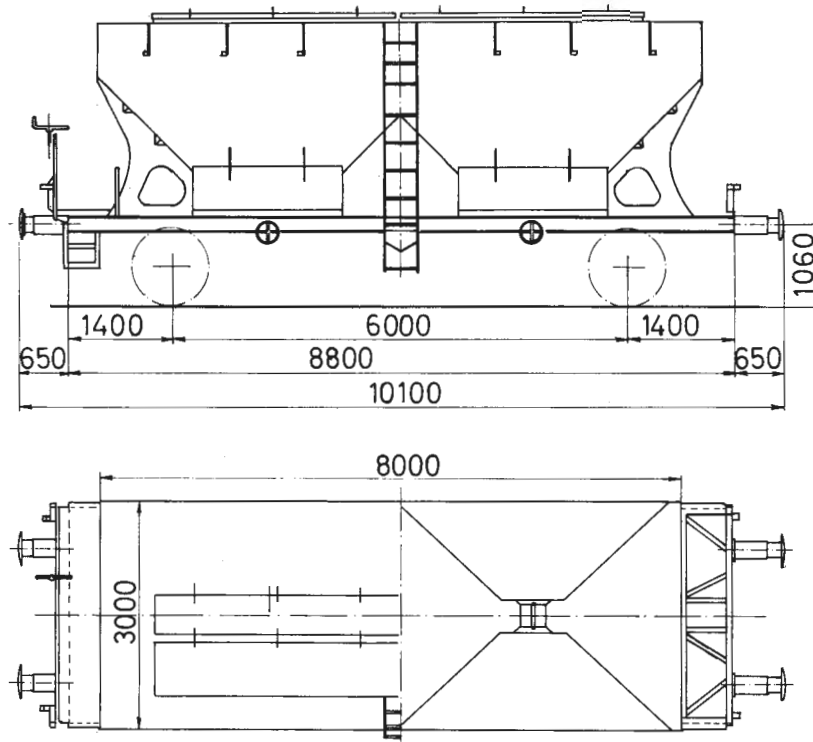

Bæreevne

A	B	C
20,0t	24,0t	

Omtrentlig vognvekt

11,5 t

Rominnhold

33,0 m³

Hovedtegning

15524

KORNTRANSPORTVOGN

Vogn nr.	Fabr.	Byggeår	Merknad	Vogn nr.	Fabr.	Byggeår	Merknad
21 76 902 9000-2	1)	41					
902 9001-0	"	42					
902 9002-8	"	"					
902 9003-6	"	"					
902 9004-4	"	"					
902 9005-1	"	"					
902 9006-9	2)	"					
902 9007-7	"	41					
902 9008-5	"	"					
902 9009-3	"	43					

1) Omb. i Dm i 1966

2) " " " " 1967

Z1

TYPE 3

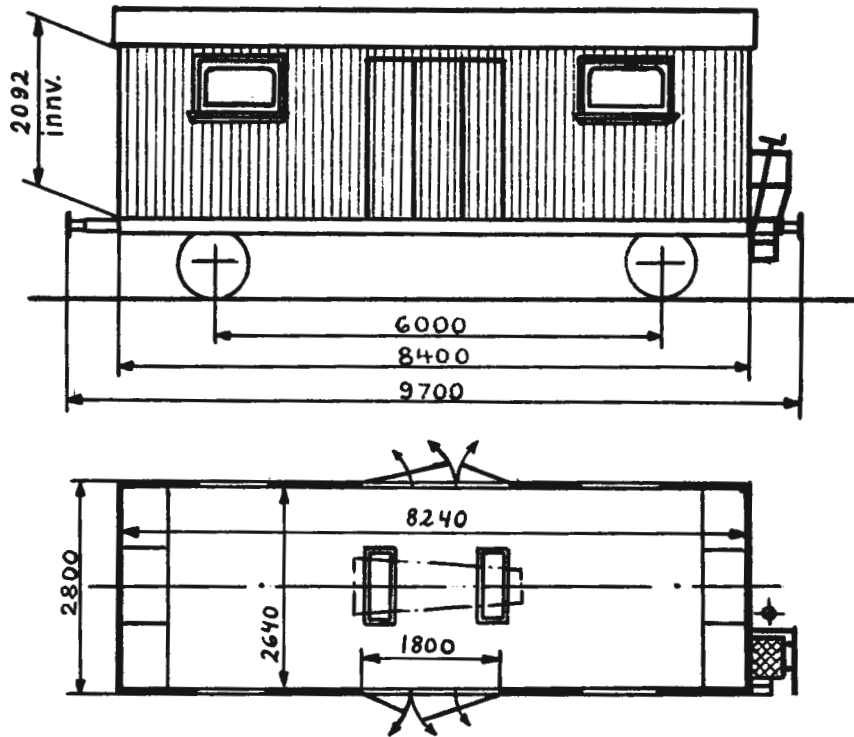

Omtrentlig vognvekt 12,5 t 1)
" bæreevne 2,0 t
Gulvflate -
Rominnhold -
Hovedtegning 3380

LIKTRANSPORTVOGN

Vogn nr.	Fabr.	Byggear	Merknad	Vogn nr.	Fabr.	Byggear	Merknad
4962	Edf	37					
9960	"	"					

1) Inkl. ballast.

Trykk nr. 752 1.7.57

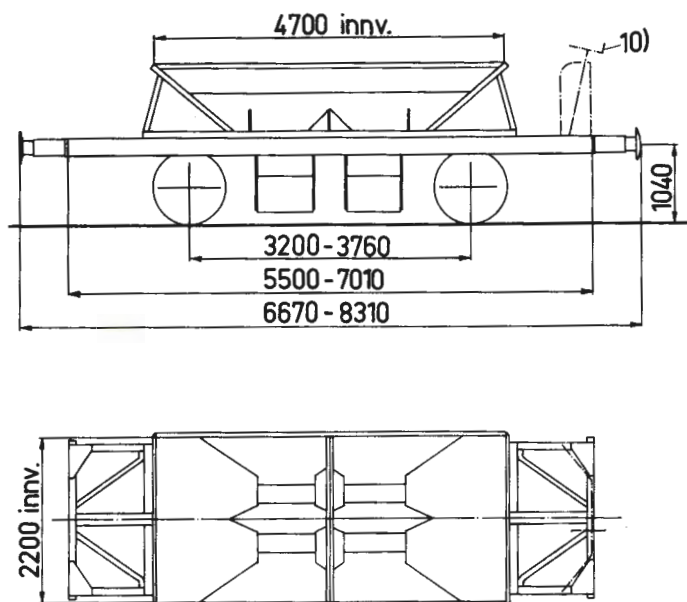

Omtrentlig vognvekt 5,5-8,0 t

" last 11,0-11,5 t

Gulvflate -

Rominnhold 7,5 m³

Hovedtegning 6291, 6439,

6624 eller 6624 + 7938

BUNNTØMMINGSVOGN

Vogn nr.	Fabr.	Byggeår	Merknad	Vogn nr.	Fabr.	Byggeår	Merknad
			H-tegn. 6291	16715	Skb	09	2)
16701	Skb	97	1) 11)	16716	"	"	2)
16702	"	12	2)	16717	"	"	2)
16703	"	"	2)	16718	"	"	2) 11)
16704	"	"	2) 11)	16719	"	"	2)
16705	"	09	2)	16720	"	"	2) 11)
16706	"	"	2)	16721	"	"	2)
16707	"	"	2)	16722	Edf	01	3)
16708	"	"	2)	16723	"	"	3) 11)
16709	"	"	2)	16724	x	⁷⁶ / ₈₂	5) 11) x) Str, Skb og Atl
16710	"	"	2)	16725	Skb	02	3) 11)
16711	"	"	2)	16726	Str	97	3) 11)
16712	"	"	2)	16727	Skb	00	3) 11)
16713	"	"	2)	16728	Str	92	4) 11)
16714	"	"	2)	16729	Atl	76	5) 11)

Opprinnelige h-tegninger: 1) 376, 2) 1033, 3) 400, 4) 47, 5) Ukjent.

10) Bare vogner med tilleggstegeting 7938 har bremseplattform.

11) Bevegelsesanordn. for tömmeluker etter tegn. 7536 og 10163.

Vogn nr.	Fabr.	Byggeår	Merknad	Vogn nr.	Fabr.	Byggeår	Merknad
16730	Str	91	4)	16763	MMV	99	3)
16731	Skb	89	4)	16764	NHJ	"	5)
			H-tegn. 6439	16765	Str	97	3) 11)
16732	KvB	93	6)	16766	"	98	3) 11)
16733	Skb	98	7)	16767	"	97	3)
16734	Str	"	5) 11)	16769	Skb	00	3) 11)
16735	Skb	00	3) 11)	16770	"	"	3) 11)
16736	Str	99	5) 11)	16771	Str	98	3) 11)
16737	MMV	"	6)	16772	Edf	00	3) 11)
16738	Str	"	6) 11)	16773	Atl	76	5) 11)
16739	"	97	5) 11)	16774	Skb	00	3) 11)
16740	"	99	5) 11)	16775	Str	99	3) 11)
16741	"	90	5) 11)	16776	"	00	3) 11)
16742	Str	92	6) 11)	16777	"	99	3) 11)
16743	KvB	93	6) 11)	16778	Skb	00	3) 11)
16744	Str	97	6) 11)	16779	"	"	3) 11)
16745	Atl	77	5) 11)	16780	"	"	3) 11)
16746	MMV	99	3) 11)	16781	Str	"	3) 11)
16747	Str	98	6)	16782	"	90	3)
16748	Edf	00	3) 11)	16783	"	"	3) 11)
16749	Str	97	3) 11)	16784	"	"	3) 11)
16750	Edf	01	6) 11)	16785	"	98	5) 11)
16751	Skb	00	3) 11)	16786	"	00	5)
16752	Atl	76	5) 11)	16787	"	97	3)
16753	Str	90	5) 11)	16788	Skb	00	3) 11)
16754	"	98	5) 11)	16789	"	"	3) 11)
16755	"	"	5) 11)	16790	"	"	3)
16756	"	"	5) 11)	16791	Str	92	6) 11)
16757	"	00	3) 11)	16792	"	89	1) 11)
16758	"	99	5) 11)	16793	"	92	6) 11)
16759	Skb	00	3) 11)	16794	Edf	00	3) 11)
16760	Str	95	5) 11)	16795	Str	99	3)
16761	"	91	5) 11)	16796	MMV	"	3)
16762	"	97	3)				

Opprinnelige h-tegninger: 1) 376, 3) 400, 4) 47, 5) Ukjent, 6) 3070, 7) B62. 11) Bevegelsesanordn. for tömmeluker etter tegn. 7536 og 10163.

Vogn nr.	Fabr.	Byggear	Merknad	Vogn nr.	Fabr.	Byggear	Merknad
			H-tegn. 6624	16831	Str	00 5) 11)	
16797	Str	00 5)		16832	"	97 6) 11)	
16798	"	99 5) 11)		16833	Oslo	15 6) 11)	
16799	"	00 5)		16834	Atl	77 5) 11)	
16800	x	22 8) 11)	x) Skb/Edf	16835	"	" 5) 11)	
16801	Str	99 5)		16836	MMV	95 6) 11)	
16802	x	22 8) 11)	x) Skb/Edf	16837	Oslo	15 5) 11)	
16803	AaB	12 8) 11)		16838	"	16 5) 11)	
16804	HJ	14 8) 11)		16839	Atl	77 5) 11)	
16805	x	22 8)	x) Skb/Edf	16840	Skb	21 8) 11)	
16806	AaB	12 8) 11)		16841	Str	00 5) 11)	
16807	HJ	14 8) 11)		16842	Edf	06 6) 11)	
16808	NHJ	99 5) 11)		16843	KvB	93 6) 11)	
16809	Str	" 3) 11)		16844	Oslo	13 6) 11)	
16810	Atl	77 5) 11)		16845	"	14 5)	
16811	Str	91 5) 11)		16846	AaB	12 6)	
16812	"	76 4)		16847	Str	92 6)	
16813	Atl	" 5)		16848	Oslo	14 5) 11)	
16814	AaB	08 5) 11)		16849	Skb	00 6)	
16815	Atl	77 5)		16850	Edf	" 6)	
16816	Oslo	15 5) 11)		16851	Oslo	14 5) 11)	
16817	Str	00 5) 11)		16852	"	16 6) 11)	
16818	x	22 8)	x) Skb/Edf	16853	"	15 5)	
16819	Str	08 9)		16854	KvB	93 6)	
16820	Atl	77 5)		16855	Edf	06 6)	
16821	x	22 8)	x) Skb/Edf	16856	Oslo	13 5)	
16822	Oslo	14 5) 11)		16857	Edf	01 6)	
16823	Str	07 5) 11)		16858	Skb	00 6) 11)	
16824	"	01 1) 11)		16859	Oslo	14 5) 11)	
16825	Oslo	15 5) 11)		16860	Str	00 6) 11)	
16826	Str	03 12)		16861	Ldv	92 6) 11)	
16827	"	08 9) 11)		16862	Edf	01 6) 11)	
16828	AaB	" 5) 11)		16863	Atl	76 6) 11)	
16829	Atl	77 5) 11)		16864	Str	00 5)	
16830	Oslo	14 5) 11)		16865	"	" 5) 11)	

Opprinnelige h-tegninger: 1) 376, 3) 400, 4) 47, 5) Ukjent, 6) 3070, 8) 876, 9) 815, 12) 690. 11) Bevegelsesanordn. for tömmeluger etter tegn. 7536 og 10163.

Vogn nr.	Fabr.	Byggeår	Merknad	Vogn nr.	Fabr.	Byggeår	Merknad
16866	HJ	14	6) 11)	16901	Edf	06	6) 11)
16867	Str	00	6) 11)				H-tegn. 6624+7938
16868	AaB	12	6) 11)	16902	Skb	17	6)
16869	Oslo	18	6) 11)	16903	HJ	14	6)
16870	Skb	00	6)	16904	Edf	00	6)
16871	Atl	77	5) 11)	16905	Skb	"	6)
16872	Ldv	92	6)	16906	Edf	06	6)
16873	Str	00	6)	16907	Skb	00	6)
16874	Oslo	15	5) 11)	16908	Edf	01	6)
16875	HJ	14	6) 11)	16909	Str	98	6)
16876	AaB	12	6) 11)	16910	Atl	15	6)
16877	"	"	6) 11)	16911	Edf	06	6)
16878	Ldv	92	6)	16912	Str	00	6)
16879	Edf	01	1)	16913	"	97	6)
16880	Oslo	14	6)	16914	Edf	01	6)
16881	Skb	00	6) 11)	16915	Skb	00	6)
16882	Str	"	5) 11)	16916	Str	97	6)
16883	AaB	12	6) 11)	16917	Edf	00	6)
16884	Edf	01	6)	16918	"	"	6)
16885	Atl	76	5) 11)	16919	Str	"	6)
16886	Str	97	6)	16920	"	01	7)
16887	Oslo	13	6) 11)	16921	Edf	00	6)
16888	Edf	06	6) 11)	16922	Atl	76	5)
16889	Oslo	15	6) 11)	16924	Str	99	6)
16890	Str	93	6) 11)	16925	Edf	01	6)
16891	KvB	"	4) 11)	16926	"	"	6)
16892	Atl	76	5) 11)	16927	Oslo	17	6)
16893	Str	97	6) 11)	16928	Ldv	92	6)
16894	"	"	6) 11)	16929	Str	00	6)
16895	HJ	14	6) 11)	16930	Oslo	15	6)
16896	Str	98	6)	16931	Str	00	6)
16897	Oslo	13	6)	16932	"	99	6)
16898	Str	99	5)	16933	AaB	12	6)
16899	Oslo	14	6) 11)	16934	Str	99	6)
16900	Str	00	6) 11)				

Opprinnelige h-tegninger: 1) 376, 4) 47, 5) Ukjent, 6) 3070, 7) 614.
11) Bevegelsesanordn. for tömmeluger etter tegn. 7536 og 10163.

Vogn nr.	Fabr.	Byggeår	Merknad	Vogn nr.	Fabr.	Byggeår	Merknad
16935	Edf	06	6)				
16936	"	01	6)				
16937	"	00	6)				
16938	Str	92	6)				
16939	AaB	12	8)				
16940	Ldv	95	6)				
16941	Str	99	6)				
16942	Skb	00	6)				
16943	Oslo	13	6)				
16944	Str	97	6)				
16945	Oslo	18	6)				
16946	Skb	08	6)				
16947	Edf	01	6)				
16948	Str	91	4)				
16949	"	97	6)				
16950	Oslo	15	6)				
16951	Str	92	6)				
			H-tegn. 6624				
14407	Str	04	7)				
			H-tegn. 6624+7938				
14419	Str	04	7)				
			H-tegn. 6439				
20808	Skb/ Edf	21	8)				

Opprinnelige h-tegninger: 4) 47, 6) 3070, 7) 614, 8) 876.

Ø 3
TYPE 1

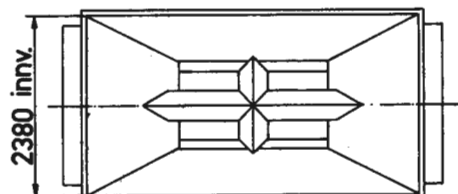
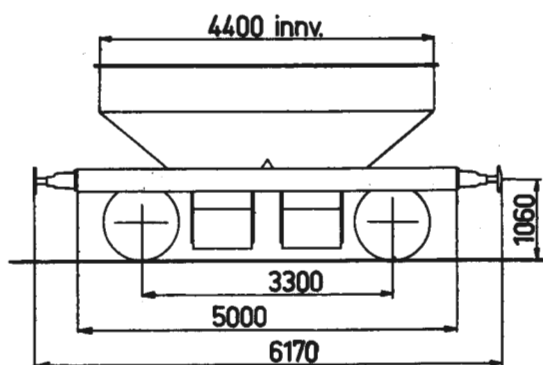

Omtrentlig vognvekt 9,5t
 " last 21,5t
 Gulvflate -
 Rominnhold 12,0 m³
 Hovedtegning N.d. M 813

BUNNTØMMINGSVOGN

Vogn nr.	Fabr.	Byggeår	Merknad	Vogn nr.	Fabr.	Byggeår	Merknad
74021	Skb	02	1)				
74022	"	"	1)				
74023	"	"	1)				
74024	Str	"	1)				

1) Ombygd fra utr. malmvogner til Ø-vogner ved NSB verkst. Nrv. (1957)
 Trykk nr. 752 1.1.59

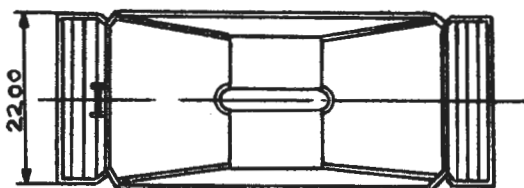
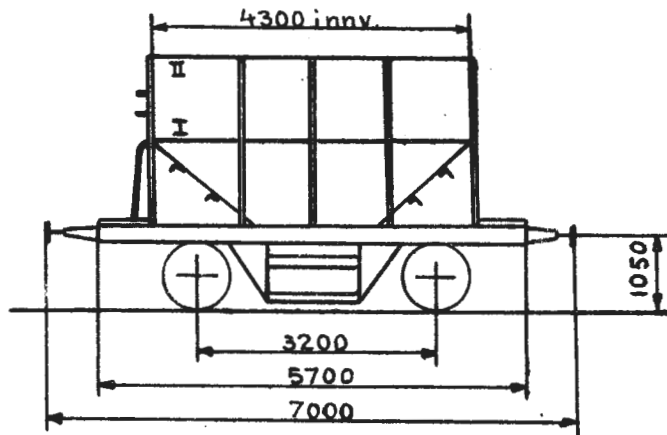

Omtrentlig vognvekt 7,0- 9,0 t
 " bæreevne 19,0-20,0 t
 Gulvflate
 Rominnhold 7,4 m³1), 17,1 m³2)
 Hovedtegning 2455

BUNNTÖMMINGSVOGN (KISVOGN)

Vogn nr.	Fabr.	Byggeår	Merknad	Vogn nr.	Fabr.	Byggeår	Merknad
17565	Str	23	3)	17581	Str	23	3)
17567	"	"	3)	17582	"	"	3)
17568	"	"	3)	17583	"	"	3)
17569	"	"		17584	"	"	3)
17570	"	"	3)	17585	"	"	3)
17571	"	"	3)	17586	"	"	3)
17572	"	"	3)	17587	"	"	3)
17573	"	"	3)	17588	"	"	3)
17574	"	"		17589	"	"	3)
17575	"	"	3)	17590	"	"	
17576	"	"	3)	17591	"	"	
17577	"	"		17592	"	"	
17578	"	"	3)	17603	Edf	29	3)
17579	"	"	3)	17604	"	"	3)
17580	"	"	3)	17605	"	"	3)

1) Ved lastemerke I. 2) Ved lastemerke II. 3) Jernkonstruksjon for presenning.

Vogn nr.	Fabr.	Byggear	Merknad	Vogn nr.	Fabr.	Byggear	Merknad
17606	Edf	29	3)				
17607	"	"	3)				
17608	"	"	3)				
17610	"	"	3)				
17611	"	"	3)				
17612	"	"	3)				
17613	"	"	3)				
17614	"	"					

3) Jernkonstruksjon for presenning.

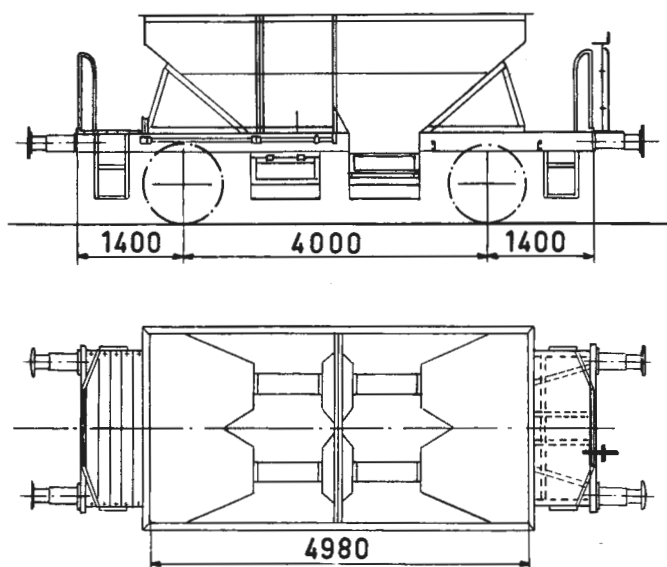

Bæreevne

A	B	C
21,0t		21,0t

Omtrentlig vognvekt 8,5-9,5t

Rominnhold 14,0 m³

Hovedtegning 8418

BUNNTÖMMINGSVOGN

Vogn nr.	Fabr.	Byggeår	Merknad	Vogn nr.	Fabr.	Byggeår	Merknad
16952	1)	1)		16966	1)	1)	
16953	"	"		16967	"	"	
16954	"	"		16968	"	"	
16955	"	"		16969	"	"	
16956	"	"		16970	"	"	
16957	"	"		16971	"	"	
16958	"	"		16972	"	"	
16959	"	"		16973	"	"	
16960	"	"		16974	"	"	
16961	"	"		16975	"	"	
16962	"	"		16976	"	"	
16963	"	"		16977	"	"	
16964	"	"		16978	"	"	
16965	"	"		16979	"	"	

1) Ombygd fra L4 vogner, innkjøpt fra Tyskland i 1916.

Vogn nr.	Fabr.	Byggeår	Merknad	Vogn nr.	Fabr.	Byggeår	Merknad
16980	1)	1)		17384	1)	1)	
16981	"	"		17385	"	"	
16982	"	"		17386	"	"	
16983	"	"		17387	"	"	
16984	"	"		17388	"	"	
16985	"	"		17389	"	"	
16986	"	"		17390	"	"	
16987	"	"		17391	"	"	
16988	"	"		17392	"	"	
16989	"	"		17393	"	"	
16990	"	"		17394	"	"	
16991	"	"		17395	"	"	
16992	"	"		17396	"	"	
16993	"	"		17397	"	"	
16994	"	"		17398	"	"	
16995	"	"		17399	"	"	
16996	"	"		17400	"	"	
16997	"	"		17401	"	"	
16998	"	"		17402	"	"	
16999	"	"		17403	"	"	
17369	"	"		17404	"	"	
17370	"	"		17405	"	"	
17371	"	"		17406	"	"	
17372	"	"		17407	"	"	
17373	"	"		17408	"	"	
17374	"	"		17409	"	"	
17375	"	"		17410	"	"	
17376	"	"		17411	"	"	
17377	"	"		17412	"	"	
17378	"	"		17413	"	"	
17379	"	"		17414	"	"	
17380	"	"		17415	"	"	
17381	"	"		17416	"	"	
17382	"	"		17417	"	"	
17383	"	"		17418	"	"	

1) Ombyggt fra L4-vogner, innkjøpt fra Tyskland i 1916.

Vogn nr.	Fabr.	Byggeår	Merknad	Vogn nr.	Fabr.	Byggeår	Merknad
17419	1)	1)		17454	1)	1)	
17420	"	"		17455	"	"	
17421	"	"		17456	"	"	
17422	"	"		17457	"	"	
17423	"	"		17458	"	"	
17424	"	"		17459	"	"	
17425	"	"		17460	"	"	
17426	"	"		17461	"	"	
17427	"	"		17462	"	"	
17428	"	"		17463	"	"	
17429	"	"		17464	"	"	
17430	"	"		17465	"	"	
17431	"	"		17466	"	"	
17432	"	"		17467	"	"	
17433	"	"		17468	"	"	
17434	"	"		17469	"	"	
17435	"	"		17470	"	"	
17436	"	"		17471	"	"	
17437	"	"		17472	"	"	
17438	"	"		17473	"	"	
17439	"	"		17474	"	"	
17440	"	"		17475	"	"	
17441	"	"		17476	2)	2)	
17442	"	"		17477	1)	1)	
17443	"	"		17478	"	"	
17444	"	"		17479	"	"	
17445	"	"		17480	"	"	
17446	"	"		17481	"	"	
17447	"	"		17482	"	"	
17448	"	"		17483	"	"	
17449	"	"		17484	"	"	
17450	"	"		17485	"	"	
17451	"	"		17486	"	"	
17452	"	"		17487	"	"	
17453	"	"		17488	"	"	

1) Ombygd fra L4-vogner, innkjøpt fra Tyskland i 1916. 2) Ombygd fra tidl. tysk L-vogn, byggeår ukjent.

Vogn nr.	Fabr.	Byggeår	Merknad	Vogn nr.	Fabr.	Byggeår	Merknad
17489	1)	1)					
17490	"	"					
17491	"	"					
17492	"	"					
17493	"	"					
17494	"	"					
17495	"	"					
17496	"	"					
17497	"	"					
17498	"	"					
17499	"	"					
17500	"	"					

1) Ombygd fra I4-vogner, innkjøpt fra Tyskland i 1916.

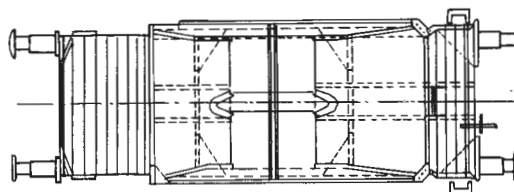
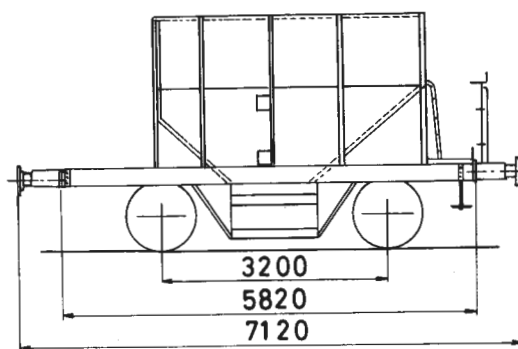

Omtrentlig vognvekt 7,0-8,0t
 " bæreevne 19,0-20,5t
 Rominnhold 1) 7,2m³ 2) 15,8m³
 Hovedtegning 2510

BUNNTÖMMINGSVOGN (KISVOGN)

Vogn nr.	Fabr.	Byggeår	Merknad	Vogn nr.	Fabr.	Byggeår	Merknad
17593	Str	23					
17594	"	"	3)				
17595	"	"	3)				
17596	"	"					
17597	"	"	3)				
17599	"	"	3)				
17600	Edf	29	3)				
17602	"	"					

1) Ved lastmerke I. 2) Ved lastmerke II. 3) Jernkonstruksjon for presenning.

Ø04

TYPE 1

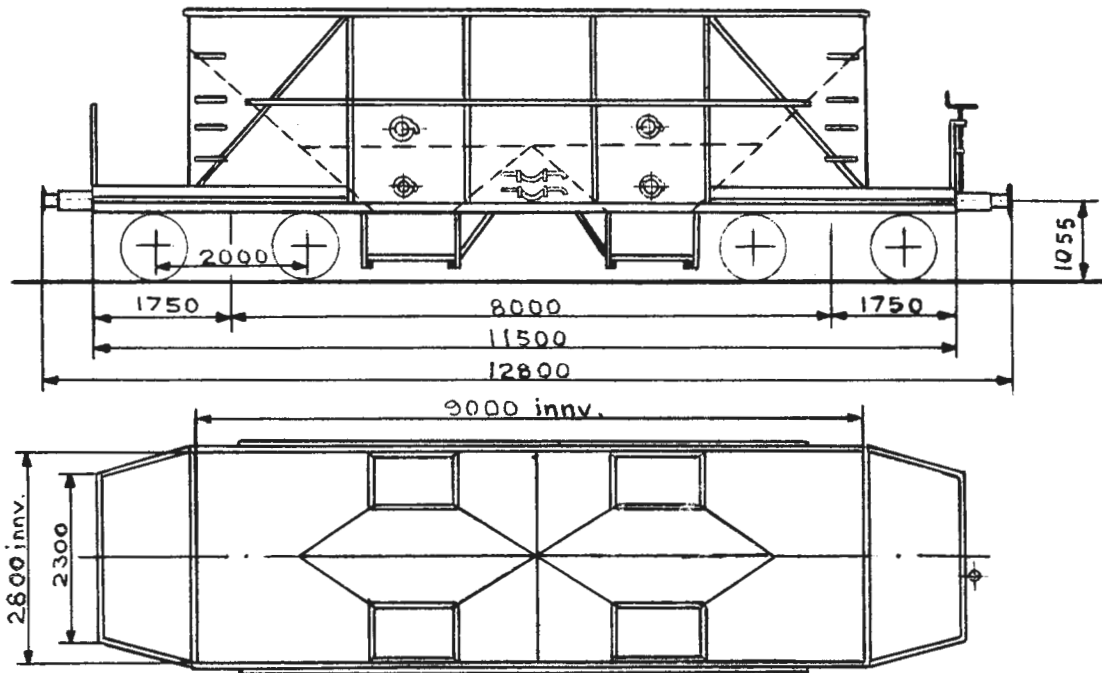

Bæreevne

A	B	C
40,0t	40,0t	

Omtrentlig vognvekt

20,0 t

Gulvflate

-

Rominnhold

45,5 m³

Hovedtegning

3420

BUNNTÖMMINGSVOGN

Vogn nr.	Fabr.	Byggeår	Merknad	Vogn nr.	Fabr.	Byggeår	Merknad
74000	Edf	33					
74001	"	"					

Ø04
TYPE 2

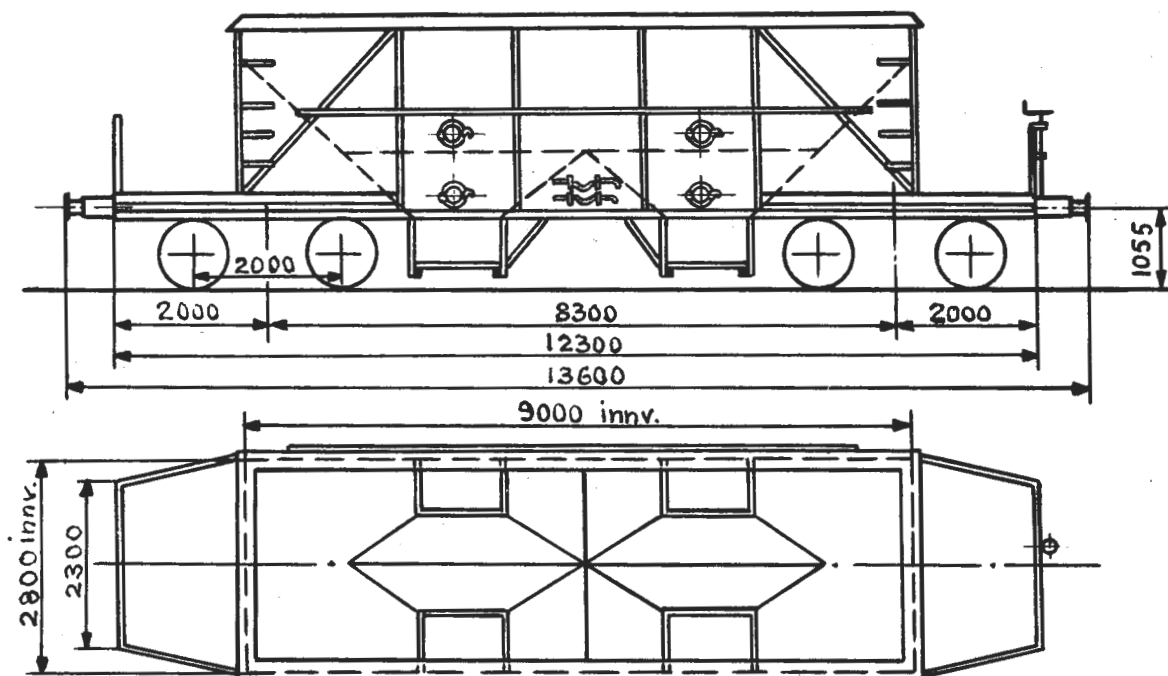

Omtrentlig vognvekt 21,0 t
 " bæreevne 39,0-39,5 t
 Gulvflate -
 Rominnhold 48,0 m³
 Hovedtegning 4670

BUNNTÖMMINGSVOGN

Vogn nr.	Fabr.	Byggeår	Merknad	Vogn nr.	Fabr.	Byggeår	Merknad
74002	Edf	40					
74003	"	"					

Ø04

TYPE 3

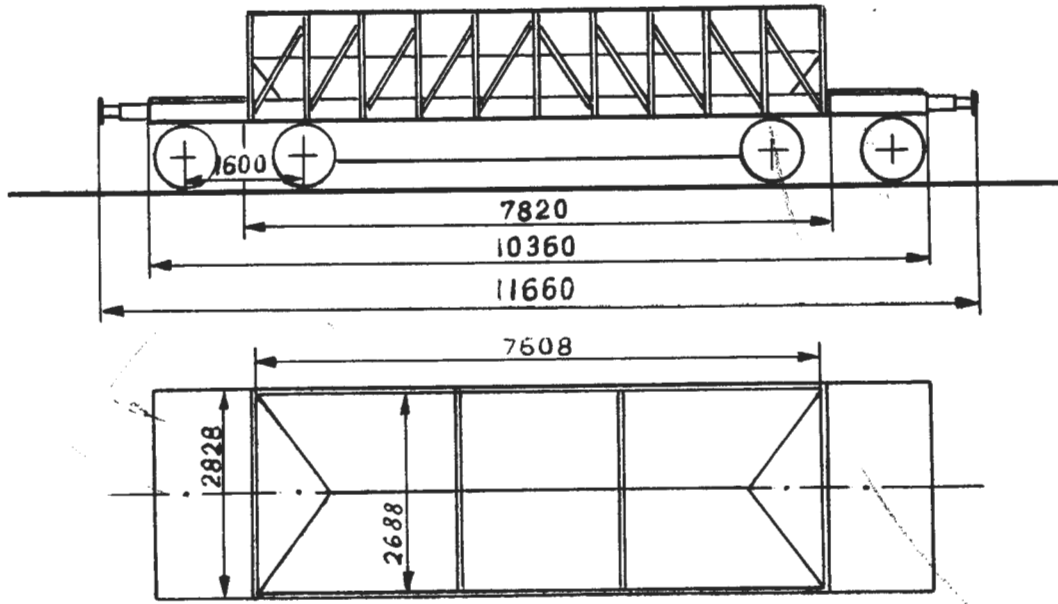

Omtrentlig vognvekt 16,0-16,5 t
 " bæreevne 42,0 t
 Gulvflate -
 Rominnhold 25,0 m³
 Hovedtegning Skabo I/ $\frac{160}{2}$ og I/ $\frac{160}{4A}$

BUNNTÖMMINGSVOGN

Vogn nr.	Fabr.	Byggeår	Merknad	Vogn nr.	Fabr.	Byggeår	Merknad
12001	Skb	06					
12002	"	"					
12003	"	"					
12004	"	"					
12005	"	"					
12006	"	"					
12008	"	"					
12009	"	"					
12010	"	"					