

752

Trykk nr. 752

Tjenesteskifter utgitt av Norges Statsbaner.

Hovedstyret.

M



ILLUSTRERT FORTEGNELSE

OVER

GODSVOGNER

NORMALSPOR

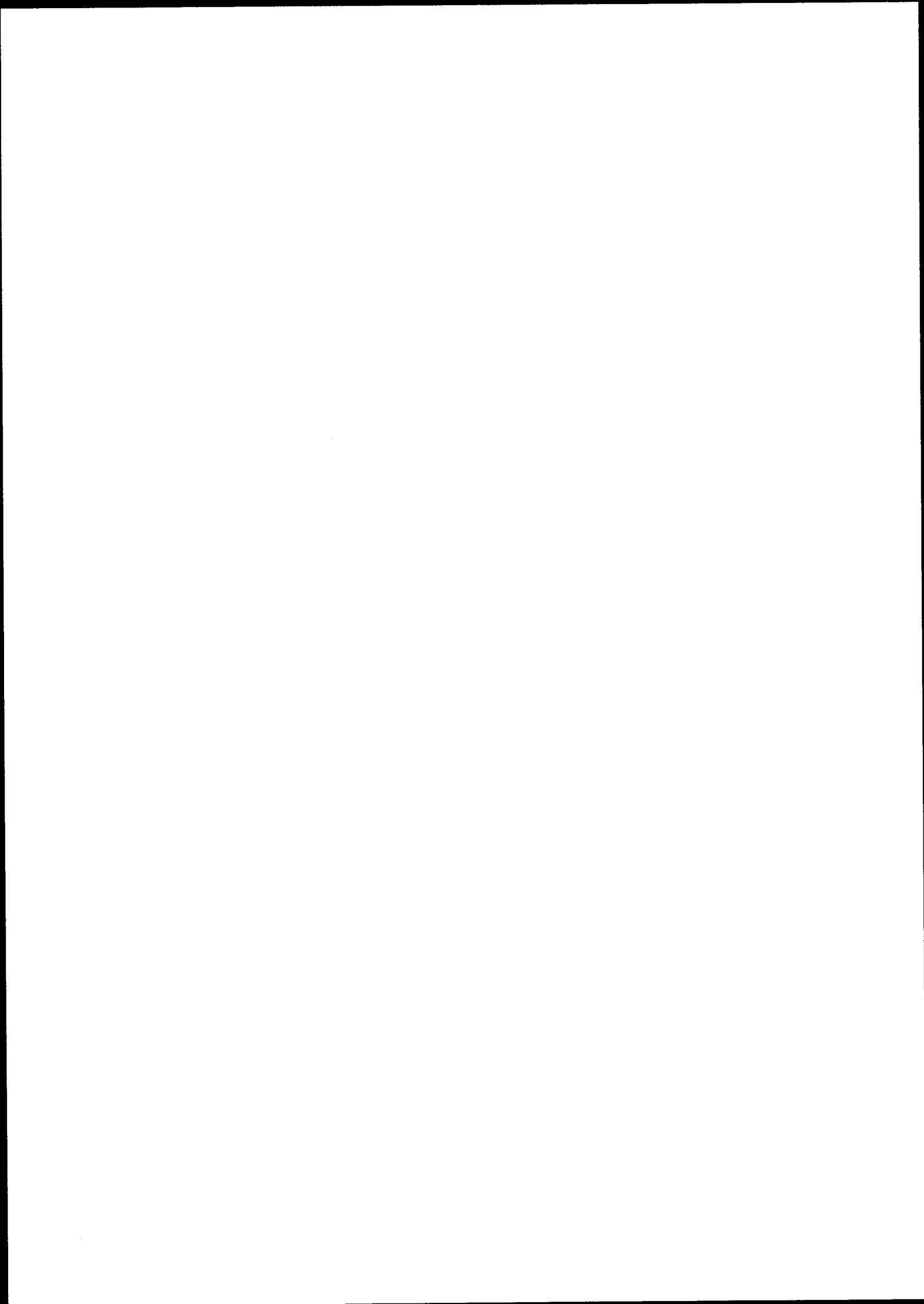

Trykk 752 pr. 1.1.1964

Vedlagt 96 blad til illustrert godsvognfortegnelse, Trykk nr. 752.
Oversikt over gjeldende blad viser hvilke som er revidert pr. 1.1.64.

Følgende typer er kommet til i tiden 1.1. - 31.12.63:

G5	type	3
Gr5	"	1
To	"	2
"	"	3
"	"	4
"	"	5

L3 type 8 er utgått.

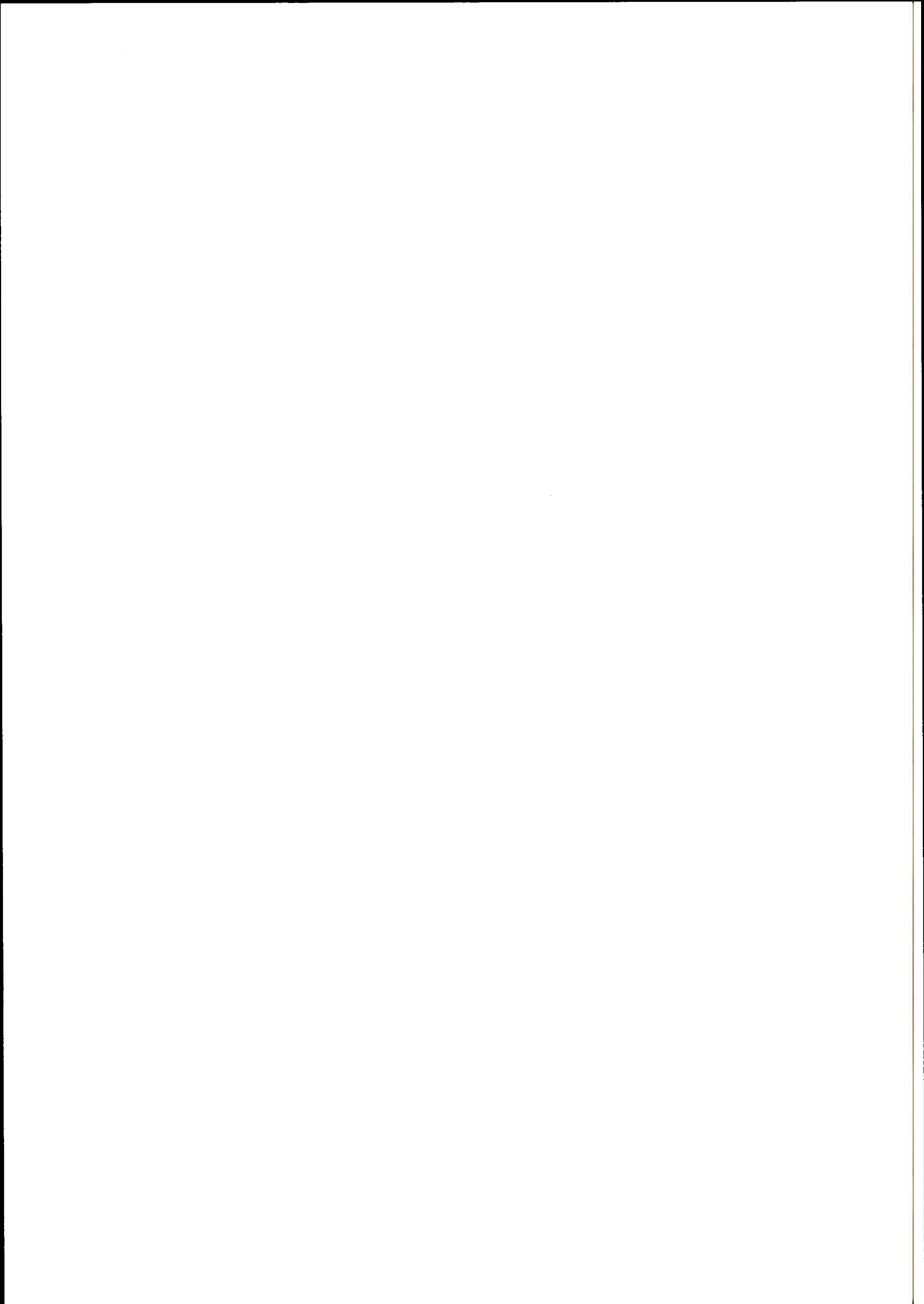

LITRABETEGNELSER

Bokstavmerket	G	=	Lukket godsvogn
"	Gh	=	Hestetransportvogn
"	Gl	=	Lukket godsvogn
"	Gp	=	" " (for reise gods i hurtig- gående persontog)
"	Gr	=	Lukket godsvogn
"	Gtk	=	" " med skyvbare vegger og tak
"	Gtl	=	" " " " " " "
"	Gv	=	Varnevogn
"	H	=	Kjölevogn
"	Hv	=	Kjöle- og varnevogn
"	K	=	Tömmervogn
"	L	=	Kassevogn
"	Lg	=	Gjödsvogn
"	Lk	=	Kalkvogn
"	Lt	=	Trekullvogn, flisvogn o.l.
"	M	=	Grusvogn
"	Ms	=	Spesial grusvogn
"	MK	=	Grus- og tömmervogn
"	N	=	Stakevogn
"	NP	=	Stake- og malmvogn
"	Q	=	Tankvogn
"	S	=	Melkvogn
"	T	=	Plattformvogn
"	Tl	=	Plattformvogn med nedleggbare jernlemmer
"	Tr	=	Transformatorvogn
"	Trq	=	"
"	Ts	=	Spesial plattformvogn
"	U	=	Massegodsvogn
"	Zl	=	Liktransportvogn
"	Ö	=	Bunntömmingsvogn

o etter bokstavmerket betegner at vognen er boggivogn

f " " " at vognen har bremsarhus

På normalt spor betegner videre:

Indeks 1:	Vogner med inntil	9	tonns akseltrykk og liten vognkasse
" 2:	" " "	9	" " og større vognkasse
" 3:	" " "	12	" "
" 4:	" " "	14-15	" "
" 5:	" " "	18	" "

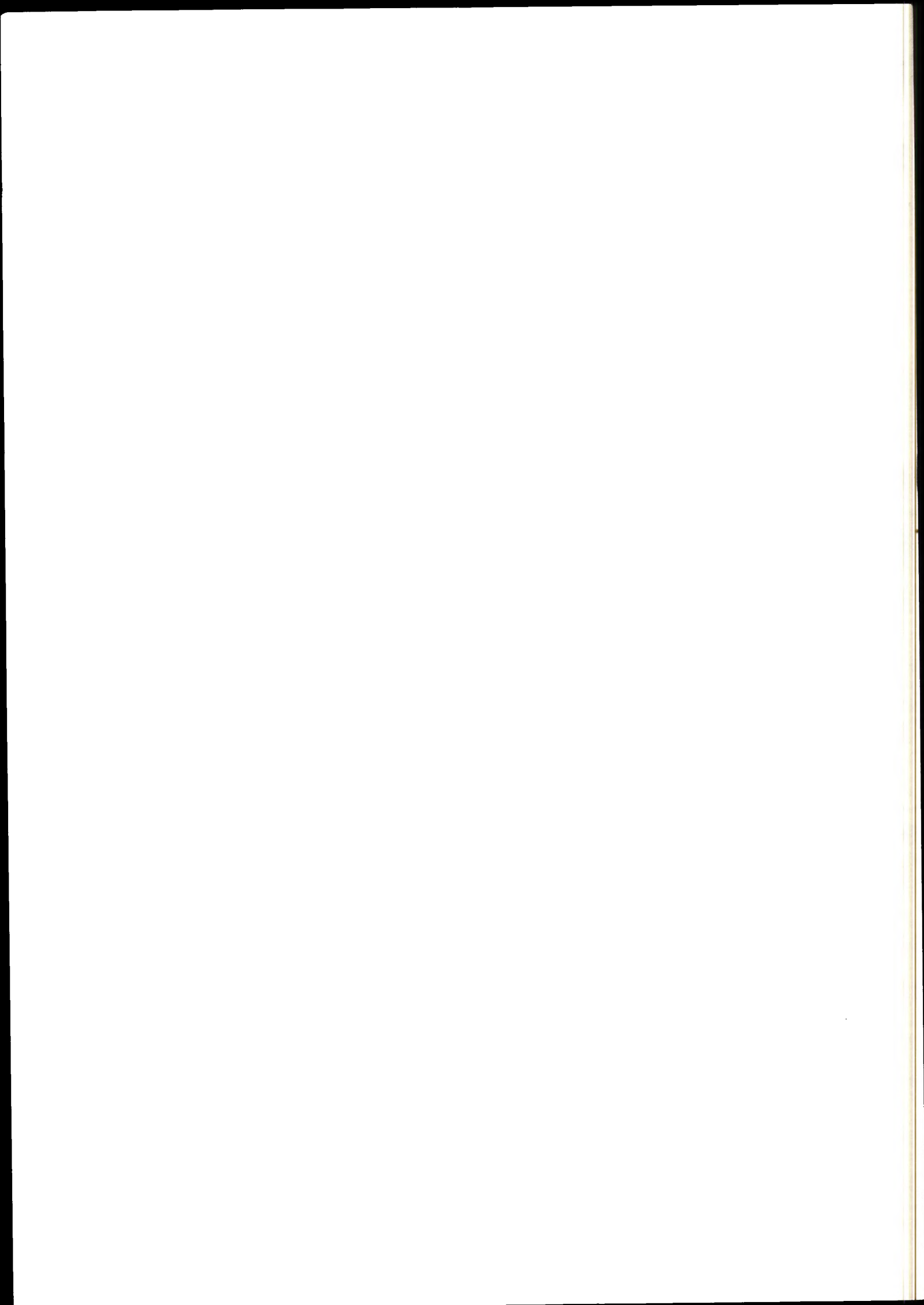

VOGNFABRIKANTER

De forskjellige vognfabrikanter er angitt i fortegnelsen med følgende forkortelser:

- AaB = Aadals Brug
- AfE = Aktiengesellschaft für fabrikation von Eisenbahn-
materiell
- AG = Astein Gesellschaft, Weimar
- AGM = Aktiengesellschaft Maschinenwerke, Göerlitz
- Atl = Atlas mek. Verksted
- BAE = Breslauer Aktiengesellschaft für Eisenbahnwagenbau
- BWM = Bohemia Waggon und Maschinenfabr.
- Edf = A/S Eidsfos Verk
- FKM = Fa. Fried. Krupp Maschinenfabriken
- FMV = Fredrikstad Mek. Verksted A/S
- Ghw = Grossh. Hauptwerkstätte, Karlsruhe
- GL = Gottfried Lindner A.G.
- GMV = Glommen Mek. Verksted A/S
- Grd = Statsbanenes verksted Grorud
- GWA = Gothaer Waggonfabrik A/G, Gotha
- HJ = Hamar Jernstøperi & Mek. Verksted
- H&R = Harney & Rödler
- Hök = A/S Höka
- JR = Jos. Rathgeber A/G
- KvB = Kværner Brug A/S
- LH = Linke-Hofmann
- Ldv = A/B Landsverk
- Lut = Gebrüder Luttgens
- MAN = Maschinenfabr. Augsburg & Nürnberg A.G.
- Mbg = Statsbanenes verksted Marienberg
- ME = Maschinenfabr. Esslingen
- MMV = Moss Mek. Verksted A/S
- NHJ = Hovedbanens verksted
- NVV = A/B Norrköpings Varv & Verkstad
- NW = Niedersächsische Waggonfabr. Jos. Graaf
- O&K = Orenstein & Koppel A.G.
- Oslo = Oslo distrikt
- RMM = Rhein-Metall. Rheinsche-Metallwaren und Maschinen-
fabrik, Düsseldorf
- RSE = Rheinstahl Siegener Eisenbahnbedarf A/G
- Sim = Simmering, Wien
- Skb = A/S Skabo

VOGNFABRIKANTER (forts.)

- SME = Societé Metallurgique d'Enghien
SMV = Skiens Mek. Verksted
Stv = Statsbanenes verksted Stavanger
Str = A/S Strömmens Værksted
WAg = Wagenfabr. Aktiengesellschaft, Köln
WAR = Waggonfabrik Aktiengesellschaft Rastatt
WD = Waggonfabr. Danzig A/G
Wgm = Wegmann
WLS = Waggonfabr. L. Steinfurt
WM = Waggon & Maschinenfabr. A/G,
Vorm. Busch Bautzen
Wmr = Weimar
Z&C = Van der Zupern & Charlier

OVERSIKT OVER GJELDENDE BLAD I TRYKK NR. 752

pr. 1.1.64. Neste revisjon 1.1.65

Side 1

SIDE (Hver enkelt side an- gis ved litrabe- tegnelsen og første og siste vognnummer)	DATO for siste revisjon	SIDE (Hver enkelt side an- gis ved litrabe- tegnelsen og første og siste vognnummer)	DATO for siste revisjon
G-1, 33210, 33652	1.1.61	G4-1, 40096, 40166	1.1.60
G-1, 33699, 34129	1.1.61	G4-1, 40167, 40236	1.1.59
G-2, 33000, 33048	1.1.61	G4-1, 40237, 40307	
G-2, 33049, 34214	1.1.61	G4-1, 40308, 40376	1.7.57
G-3, 34223	1.1.62	G4-1, 40377, 40447	1.1.62
G1-1, 5066, 15165	1.1.60	G4-1, 40448, 40515	1.1.64
G1-2, 1142, 8084	1.1.59	G4-1, 40516, 40584	1.1.62
G1-3, 8409, 8414	1.1.64	G4-1, 40585, 40654	1.1.59
G2-1, 1166, 3241	1.1.64	G4-1, 40655, 40724	1.1.61
G2-1, 3243, 20648	1.1.64	G4-1, 40725, 40795	1.7.57
G2-2, 16327	1.1.61	G4-1, 40796, 40862	1.1.64
G2-4, 2053, 17080	1.1.64	G4-1, 40863, 40932	1.1.59
G2-5, 6272, 12157	1.1.64	G4-1, 40933, 41003	1.1.61
G2-6, 1237, 14187	1.1.64	G4-1, 41004, 41073	
G3-1, 2945, 3087	1.1.64	G4-1, 41074, 41142	
G3-1, 3089, 3331	1.1.64	G4-1, 41143, 41211	1.7.56
G3-1, 3332, 5454	1.1.64	G4-1, 41212, 41279	1.1.60
G3-1, 5456, 8172	1.1.64	G4-1, 41280, 41348	1.1.59
G3-1, 8173, 8387	1.1.64	G4-1, 41349, 41418	1.1.59
G3-1, 8389, 14123	1.1.64	G4-1, 41419, 41839	1.1.62
G3-1, 14124, 15264	1.1.64	G4-1, 41840, 41887	1.1.63
G3-1, 15265, 15394	1.1.64	G4-2, 42002, 42028	1.1.63
G3-1, 15395, 20787	1.1.64	G4-2, 42029, 42104	1.1.64
G3-1, 20789, 23384	1.1.64	G4-2, 42105, 42174	1.1.61
G3-2, 31028, 32044	1.1.64	G4-2, 42175, 42244	1.7.56
G3-3, 31001, 31012	1.1.64	G4-2, 42245, 42314	1.7.56
G3-4, 3161, 6288	1.1.64	G4-2, 42315, 42352	1.7.56
G3-4, 6289, 23074	1.1.64	G5-1, 43000, 43029	1.1.59
G3-5, 6276, 6286	1.1.64	G5-1, 43030, 43034	1.1.59
G3-6, 3106	1.1.63	G5-2, 43035, 43048	1.1.63
G4-1, 40000, 40028	1.1.64	G5-2, 43049, 43118	1.1.62
G4-1, 40029, 40095		G5-2, 43119, 43188	1.1.62

Der hvor datorubrikken står åpen, gjelder datoen for den opprinnelige utgave: 1.7.54.

OVERSIKT OVER GJELDENE BLAD I TRYKK NR. 752

pr. 1.1.64. Neste revisjon 1.1.65

Side 2

SIDE (Hver enkelt side angis ved litrabetegnelsen og første og siste vognnummer)	DATO for siste revisjon	SIDE (Hver enkelt side angis ved litrabetegnelsen og første og siste vognnummer)	DATO for siste revisjon
G5-2, 43189, 43258	1.1.62	H3-1, 13223, 13298	1.1.64
G5-2, 43259, 43331	1.1.63	H3-1, 13299, 13370	1.1.64
G5-2, 43332, 43401	1.1.63	H3-1, 13372, 13406	1.1.64
G5-2, 43402, 43409	1.1.63	H4-1, 70001, 70024	1.1.63
G5-3, 43410, 43437	1.1.64	H4-2, 70026, 70074	1.1.64
G5-3, 43438, 43507	1.1.64	Hf3-1, 13249, 13400	1.1.62
G5-3, 43508, 43561	1.1.64	Hf4-1, 70018	1.1.62
G5-4, 44000, 44001	1.1.63	Hf4-2, 70025, 70070	1.1.64
Gf2-1, 6266, 8116	1.1.64	Hv3-1, 5580, 13380	1.1.64
Gf2-2, 2056, 14077	1.1.64	Hv4-1, 70000, 70015	1.1.62
Gf3-1, 6284, 6285	1.1.64	Hv4-2, 70067	1.1.64
Gf3-2, 13011, 13020		Hvf4-2, 70033, 70058	1.1.64
Gf3-3, 5095, 23071	1.1.64	K1-1, 2153, 2160	1.1.61
Gfo2-1, 6201, 14102	1.1.64	K1-2, 1384, 2260	1.1.63
Gfo2-1, 14103, 20764	1.1.64	K1-3, 1313	1.1.64
Gfo2-2, 3335, 5152	1.1.64	K2-1, 15502, 23056	1.1.63
Gfo2-2, 5702, 14136	1.1.64	K2-1, 23057, 23441	1.1.63
Gfo2-3, 3397, 15407	1.1.64	L1-1, 1420, 1569	1.1.62
Gh4-1, 1250	1.1.62	L1-2, 6734, 15708	1.1.62
G14-1, 48000, 48027	1.1.62	L2-1, 2919	1.1.63
G14-1, 48028, 48049	1.1.63	L3-1, 13033, 13038	1.1.64
Gp4-1, 33100, 33127	1.1.64	L3-2, 3123, 3717	1.1.64
Gp4-1, 33128, 34901	1.1.64	L3-2, 3719, 10574	1.1.64
Gr5-1, 46000, 46027	1.1.64	L3-2, 10575, 15830	1.1.64
Gr5-1, 46028, 46213	1.1.64	L3-2, 15832, 16583	1.1.64
Gr5-1, 46214, 46234	1.1.64	L3-2, 16584, 20751	1.1.64
Gtk5-1, 49500, 49519	1.1.63	L3-3, 17537, 17539	1.1.64
Gt15-1, 49000, 49009	1.1.63	L3-5, 2788, 15785	1.1.64
Gv2-1, 12166, 14184	1.1.64	L3-5, 15789, 15805	1.1.64
H-1, 70500	1.1.64	L3-7, 10042, 15455	1.1.64
H3-1, 13100, 13129	1.1.63	L4-1, 10552, 11179	1.1.64
H3-1, 13130, 13222	1.1.64	L4-1, 11182, 32287	1.1.64

Der hvor datorubrikken står åpen, gjelder datoen for den opprinnelige utgave: 1.7.54.

OVERSIKT OVER GJELDENE BLAD I TRYKK NR. 752

pr. 1.1.64. Neste revisjon 1.1.65

Side 3

SIDE (Hver enkelt side an- gis ved litrabe- tegnelsen og første og siste vognnummer)	DATO for siste revisjon	SIDE (Hver enkelt side an- gis ved litrabe- tegnelsen og første og siste vognnummer)	DATO for siste revisjon
L4-1, 32289, 32606	1.1.64	Mf1-1, 2364, 3816	1.1.64
L4-1, 32609, 32669	1.1.64	Mf1-2, 8283, 20530	1.1.62
L4-2, 11191, 32141	1.1.64	Mf2-1, 5490, 23495	1.1.64
L4-2, 32144, 32654	1.1.64	Ms3-1, 8222, 8237	1.1.64
L4-3, 50001, 50044	1.1.64	Ms3-2, 2126, 15886	1.1.64
L4-3, 50045, 50136	1.1.63	Ms3-2, 15887, 15899	1.1.63
L4-3, 50137, 50208	1.1.63	Msf3-1, 8224, 8240	1.1.63
L4-3, 50209, 50281	1.1.64	Msf3-2, 6992, 15900	1.1.64
L4-3, 50282, 50371	1.1.64	MK1-1, 6150, 12404	1.1.64
L4-3, 50372, 50468	1.1.63	MK3-1, 20231, 20250	1.1.63
Lo3-1, 23701, 23724	1.1.64	N1-1, 1818, 8584	1.1.64
Lf3-1, 13001, 13085		N1-1, 8597, 20846	1.1.64
Lf4-1, 11396, 32628	1.1.64	N1-2, 1675, 10834	1.1.64
Lg1-1, 2303, 11450	1.1.64	N1-2, 11665, 11688	1.1.64
Lg3-1, 9808, 9810	1.1.64	N2-1, 2402, 6454	1.1.64
Lk1-1, 5166, 15965	1.1.64	N2-1, 7549, 11900	1.1.64
Lk3-1, 6711, 15913	1.1.63	N2-2, 3634, 3838	1.1.64
Lk3-1, 15914, 16515	1.1.63	N2-2, 3839, 5355	1.1.64
Lt2-2, 7610	1.1.63	N2-2, 5356, 6501	1.1.64
Lt2-3, 7616, 7718	1.1.64	N2-2, 6507, 8636	1.1.64
Lt2-3, 7725, 7745	1.1.64	N2-2, 8638, 9615	1.1.64
Lt4-1, 7100, 7129	1.1.60	N2-2, 9616, 16417	1.1.64
M1-1, 2267, 2392	1.1.64	N2-2, 16418, 20139	1.1.64
M1-1, 2394, 6378	1.1.64	N2-2, 20140, 23006	1.1.64
M1-1, 6383, 11529	1.1.64	N2-3, 2441, 5289	1.1.64
M1-1, 11530, 20829	1.1.64	N2-3, 5292 16454	1.1.64
M1-1, 20830, 20849	1.1.64	N2-3, 16458, 16462	1.1.64
M1-2, 8244, 8274	1.1.64	N2-4, 6425, 12551	1.1.62
M1-2, 8275, 20527	1.1.64	N2-5, 2710, 2713	1.1.61
M1-3, 23389	1.1.64	N3-1, 13005, 13096	
M2-1, 5495, 23022	1.1.64	No1-1, 15992	1.1.64
M2-1, 23023, 23493	1.1.64	No2-1, 6847, 10939	1.1.63

Der hvor datorubrikken står åpen, gjelder datoen for den opprinnelige utgave: 1.7.54.

OVERSIKT OVER GJELDENE BLAD I TRYKK NR. 752

pr. 1.1.64. Neste revisjon 1.1.65

Side 4

SIDE (Hver enkelt side an- gis ved litrabe- tegnelsen og første og siste vognnummer)	DATO for siste revisjon	SIDE (Hver enkelt side an- gis ved litrabe- tegnelsen og første og siste vognnummer)	DATO for siste revisjon
Nf2-1, 12547, 12548	1.1.62	To-4, 38213, 38244	1.1.64
Nfo2-1, 10938	1.1.63	To-5, 38207, 38248	1.1.64
NP2-1, 5309, 16363	1.1.64	To1-1, 14901, 15997	1.1.64
NP3-1, 13054, 13095	1.1.60	To3-1, 6841, 6845	
NPo3-1, 13042, 13081	1.1.61	To4-1, 60416, 60446	1.1.63
Q3-2, 4956, 4988	1.7.57	To4-1, 60447, 60485	
Q3-3, 11301, 11302	1.7.57	To4-2, 65000, 65019	1.1.60
Q4-1, 60080, 60163		Tl-1, 38395, 38422	1.1.63
Q4-2, 11303, 73012	1.1.62	Tl-1, 38423, 38492	1.1.63
Q4-3, 73013, 73027	1.1.59	Tl-1, 38493, 38562	1.1.63
S1-1, 4511, 6927	1.1.63	Tl-1, 38563, 38599	1.1.63
S3-1, 2900, 4530	1.1.61	T13-1, 2985, 4246	1.1.60
S3-1, 4531, 20772	1.1.63	T13-1, 4247, 5469	1.1.63
S3-2, 2903, 2970	1.1.61	T13-1, 5470, 6790	1.7.56
Sf1-2, 6931, 17530	1.1.63	T13-1, 6791, 7000	1.1.64
Sf3-1, 4527	1.1.61	T13-1, 10441, 10533	1.1.64
Sf3-2, 2902, 16588	1.1.61	T13-1, 10534, 10700	1.1.61
T-1, 38601	1.1.63	T13-1, 10914, 10993	1.1.64
T3-1, 4802, 4830	1.1.63	T13-1, 10994, 15554	1.1.64
T3-1, 4831, 6549	1.1.63	T13-1, 15555, 16517	1.7.57
T3-1, 6550, 6620	1.1.64	T13-1, 16518, 17163	1.1.62
T3-1, 6621, 14525	1.1.64	T14-1, 60206, 60234	1.1.61
T3-1, 14526, 17133	1.1.64	T14-1, 60235, 60303	1.7.56
T3-1, 17134, 17564	1.1.63	T14-1, 60304, 60373	1.7.56
T3-2, 11901, 11935	1.1.64	T14-1, 60374, 60524	
T3-3, 23434	1.1.59	T14-1, 60525, 60594	1.1.62
T4-1, 60000, 60028	1.1.63	T14-1, 60595, 60663	1.1.63
T4-1, 60029, 60099	1.1.62	T14-1, 60664, 60734	
T4-1, 60100, 60174	1.1.63	T14-1, 60736, 60805	1.1.62
T4-1, 60175, 60205	1.1.62	T14-1, 60806, 60877	1.7.56
To-2, 38211	1.1.64	T14-1, 60878, 60947	
To-3, 38212, 38226	1.1.64	T14-1, 60948, 61016	1.7.56

Der hvor datorubrikken står åpen, gjelder datoen for den opprinnelige utgave: 1.7.54.

OVERSIKT OVER GJELDENE BLAD I TRYKK NR. 752

pr. 1.1.64. Neste revisjon 1.1.65

Side 5

SIDE (Hver enkelt side an- gis ved litrabe- tegnelsen og første og siste vognnummer)	DATO for siste revisjon	SIDE (Hver enkelt side an- gis ved litrabe- tegnelsen og første og siste vognnummer)	DATO for siste revisjon
T14-1, 61017, 61086	1.1.63	Ö4-1, 17565, 17604	
T14-1, 61087, 61156		Ö4-1, 17605, 17614	
T14-1, 61157, 61226	1.1.64	Ö4-2, 16952, 16979	1.1.62
T14-1, 61227, 61295	1.1.63	Ö4-2, 16980, 17400	1.1.63
T14-1, 61296, 61365	1.1.63	Ö4-3, 17593, 17600	1.1.64
T14-1, 61366, 61370	1.1.63	Öo4-1, 74000, 74001	1.1.61
T15-1, 62000, 62027	1.1.64	Öo4-2, 74002, 74003	1.1.63
T15-1, 62028, 62097	1.1.64	Öo4-3, 12001, 12010	1.1.62
T15-1, 62098, 62111	1.1.64	Öf4-1, 17598, 17602	1.1.64
T1o3-1, 4926, 16591	1.1.61		
T1o4-1, 60486, 60495	1.1.60		
Tr5-1, 16510, 16511	1.1.59		
Tro-1, 39000	1.1.63		
Tro4-1, 16506			
Tro4-2, 16505	1.1.59		
Tro5-1, 16507	1.1.59		
Trqo-1, 16000	1.1.63		
Tso2-1, 4380, 15991	1.1.63		
Tso2-2, 17164	1.1.63		
Tso3-1, 5405, 15994	1.1.61		
Tsfo3-1, 5406, 15995	1.1.61		
U4-1, 75000, 75003	1.1.61		
U4-2, 75100, 75129	1.1.64		
U5-1, 75004, 75007	1.1.63		
Z1-2, 10315	1.1.62		
Z1-3, 4962, 9960	1.7.57		
Ö2-1, 16701, 16729	1.1.64		
Ö2-1, 16730, 16796	1.1.64		
Ö2-1, 16797, 16865	1.1.64		
Ö2-1, 16866, 16934	1.1.64		
Ö2-1, 16935, 16951	1.1.60		
Ö3-1, 74021, 74024	1.1.59		

Der hvor datorubrikken står åpen, gjelder datoen for den opprinnelige utgave: 1.7.54.

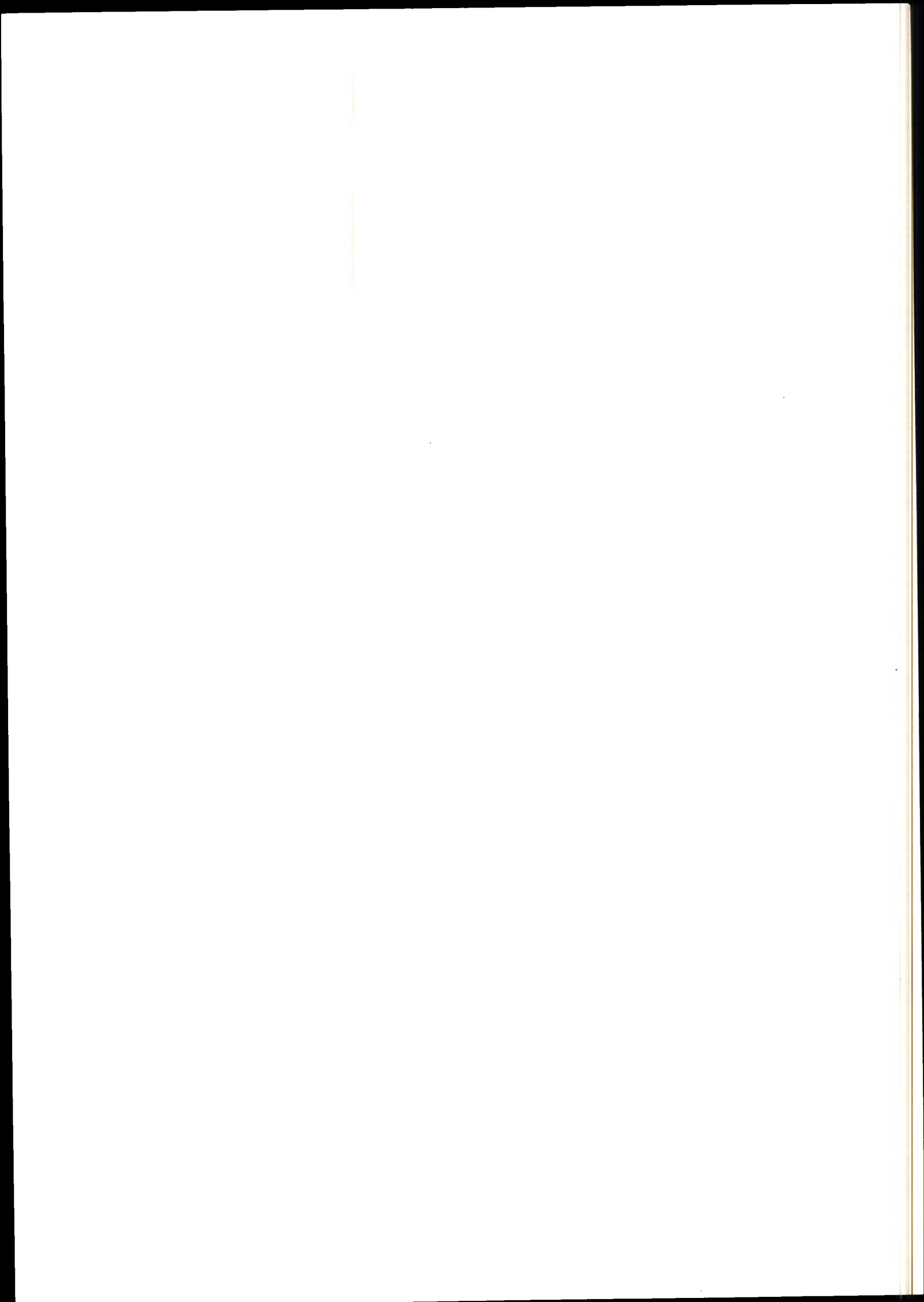

G1
TYPE 3

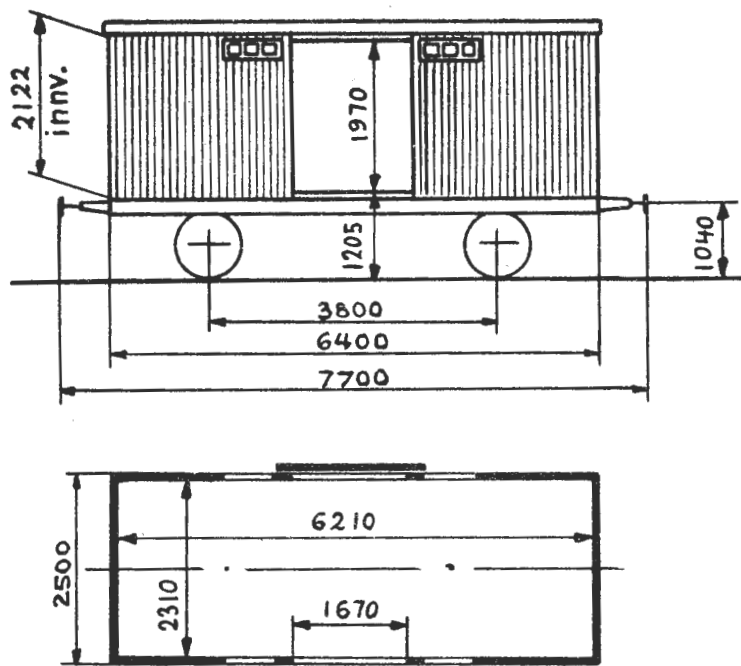

Omtrentlig vognvekt 6,5-7,0 t
 " last 10,0 t
 Gulvflate 14,3 m²
 Rominnhold 29,5 m³
 Hovedtegning 1421

LUKKET GODSVOGN

Vogn nr.	Fabr.	Byggeår	Merknad	Vogn nr.	Fabr.	Byggeår	Merknad
8409	Str	12					
8412	"	"					
8414	"	"					

G2

TYPE 1

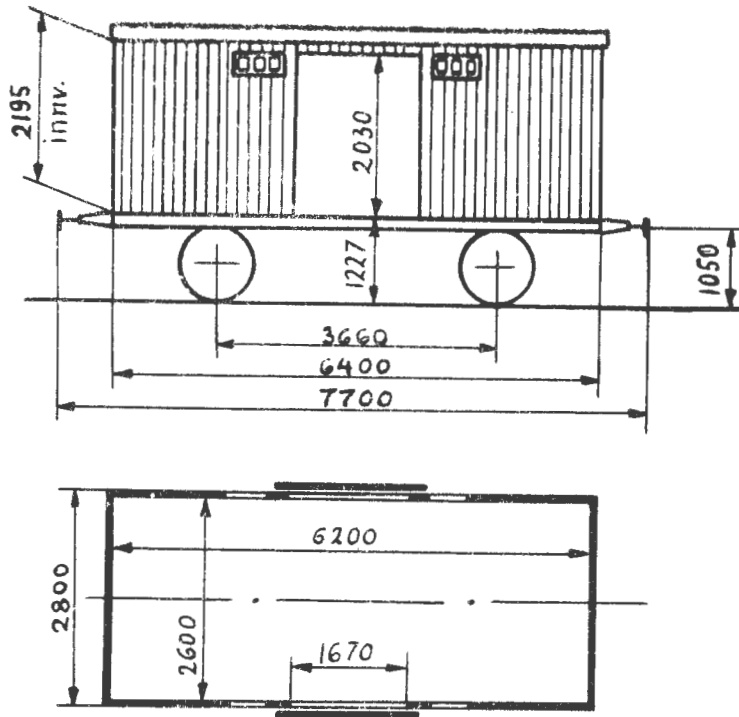

Bæreevne

A	B	C
11,0t	11,0t	

Omtrentlig vognvekt 7,0-8,5 t₂
 Gulvflate 16,1 m²
 Rominnhold 34,0 m³
 Hovedtegning B 62, 376

LUKKET GODSVOGN

Vogn nr.	Fabr.	Byggeår	Merknad	Vogn nr.	Fabr.	Byggeår	Merknad
			H-tegn. B 62	1230	Str	10	
1166	Skb	97					H-tegn. 376
1169	"	98		1232	Str	10	
1172	"	"		2955	Skb	"	
1200	NHJ	08		2959	"	"	
1202	"	"		2960	"	"	
1203	"	09		2963	"	"	
1204	"	"		2964	"	"	
1207	"	"		2965	"	"	
1210	"	"		2966	"	"	
1211	"	"		3182	Str	00	1)
1212	"	"		3197	"	"	
1217	Str	10		3217	"	01	
1222	"	"		3240	"	"	
1228	"	"		3241	"	"	

1) Innredet for kjøttransport.

Vogn nr.	Fabr.	Byggeår	Merknad	Vogn nr.	Fabr.	Byggeår	Merknad
3243	Str	01		14170	Str	05	
3247	"	"		14171	"	"	
3258	"	"		14172	"	"	
3289	Edf	"		14182	Skb	10	
3296	"	"		14192	"	"	
3300	"	"		14193	"	"	3)
3301	"	"	2)	14194	"	"	4)
3310	"	08		14195	"	"	
5080	Str	10		14196	"	"	
5081	"	"		20614	Edf	18	
5088	"	"		20648	"	"	
5090	"	"					
6070	Wgm	97					
7069	Skb	10					
7072	"	"					
8097	"	97					
8121	"	99					
8124	"	"					
8127	"	"					
9232	"	09					
9233	"	"					
9235	"	"					
9238	"	"					
9247	"	"					
9249	"	"					
10307	"	06					
10309	"	"					
10324	Edf	10					
10325	"	"					
10327	"	"					
10328	"	"					
10332	"	"					
10338	"	"					
12162	Str	"					
12167	"	"					

2) Innredet for melktransport. 3) Ballast + v.v. = 9,4 t.
4) Ballast + v.v. = 9,2 t.

G2

TYPE 2

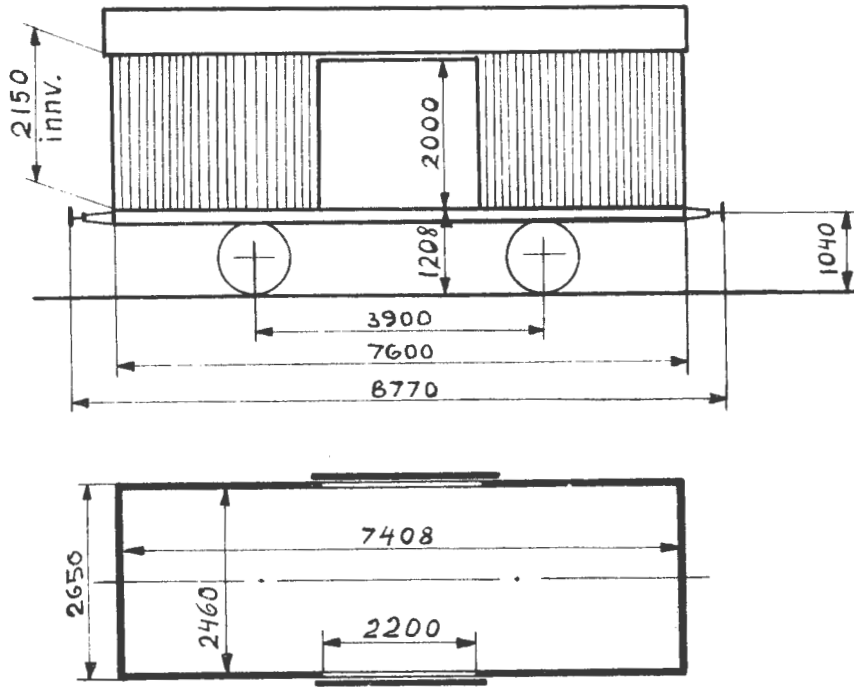

Bæreevne

A	B	C
10,5t	10,5t	

Omtrentlig vognvekt 8,0 t
 Gulvflate 18,2 m²
 Rominnhold 39,2 m³
 Hovedtegning 815 + D 2863

LUKKET GODSVOGN

Vogn nr.	Fabr.	Byggeår	Merknad	Vogn nr.	Fabr.	Byggeår	Merknad
16327	AaB	09	1)				

1) Benyttes til papirtransport.

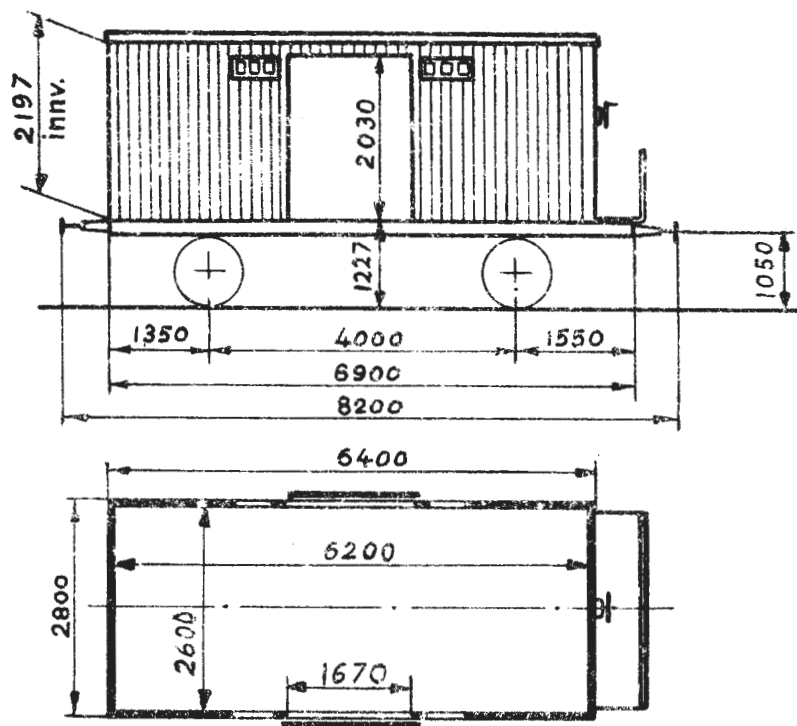

Omtrentlig vognvekt 7,5- 8,5 t
 " bæreevne 9,5-10,5 t
 Gulvflate 16,1 m²
 Rominnhold 34,0 m³
 Hovedtegning 376 + skisse 233

LUKKET GODSVOGN

Vogn nr.	Fabr.	Byggeår	Merknad	Vogn nr.	Fabr.	Byggeår	Merknad
2053	Skb	10		17059	Skb	10	
2055	"	"		17064	"	"	
2059	"	"		17067	"	"	
2117	"	11		17070	"	"	
2841	"	10		17074	"	"	
2849	"	"		17080	"	"	
2850	"	"					
14067	Edf	"					
14075	"	"					
14078	"	"					
14079	"	"					
14081	"	"					
14083	"	"					
14085	"	"					
17053	Skb	"					

G2

TYPE 5

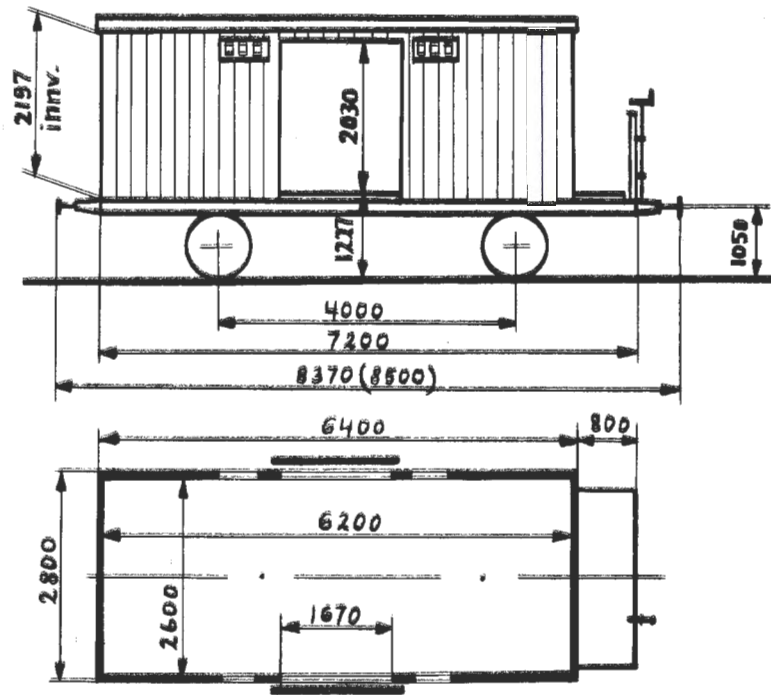

Omtrentlig vognvekt 7,0- 8,0 t
 " bæreevne 10,0-11,0 t
 Gulvflate 16,1 m²
 Rominnhold 34,0 m³
 Hovedtegning 376 + skisse nr. 1085

LUKKET GODSVOGN

Vogn nr.	Fabr.	Byggeår	Merknad	Vogn nr.	Fabr.	Byggeår	Merknad
6272	Edf	05					
12157	Str	00					

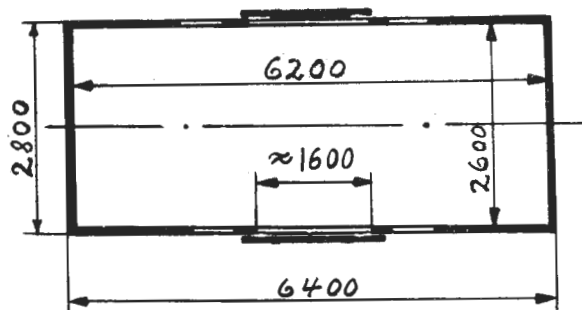
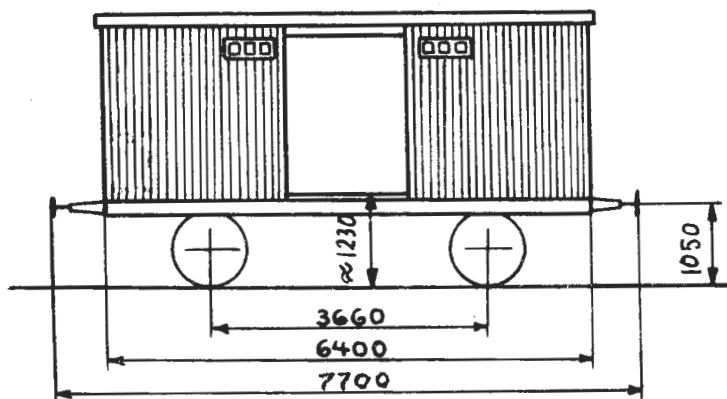

Omtrentlig vognvekt	7,5- 8,5 t
" bæreevne	9,5-10,5 t
Gulvflate	16,1 m ²
Rominnhold	34,0 m ³
Hovedtegning	376

LUKKET GODSVOGN

Vogn nr.	Fabr.	Byggeår	Merknad	Vogn nr.	Fabr.	Byggeår	Merknad
1237	NHJ	12					
1239	"	"					
12165	Str	10					
14177	Skb	"					
14185	"	"					
14187	"	"					

G3

TYPE 1

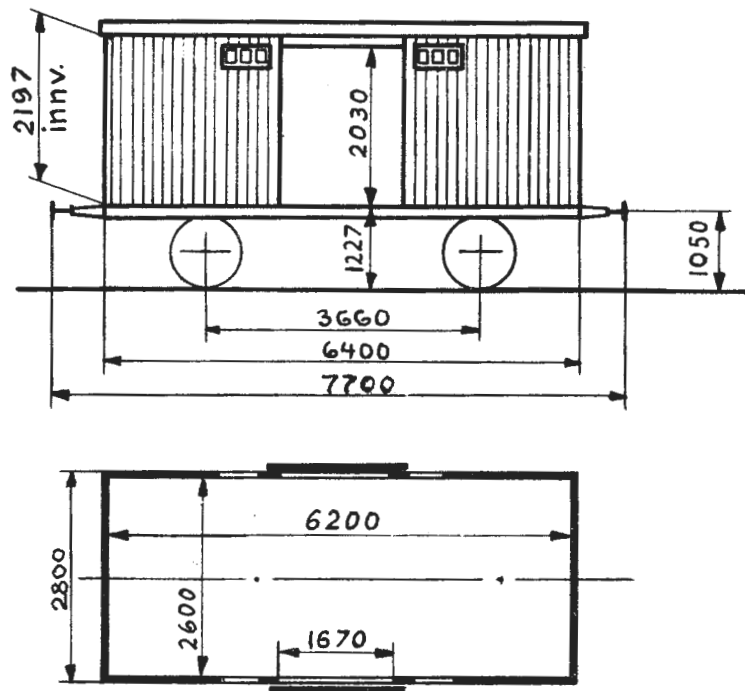

Bæreevne

A	B	C
16,0t	16,0t	

Omtrentlig vognvekt

7,5-9,0 t

Gulvflate

16,1 m²

Rominnhold

34,0 m³

Hovedtegning

376

LUKKET GODSVOGN

Vogn nr.	Fabr.	Byggeår	Merknad	Vogn nr.	Fabr.	Byggeår	Merknad
2945	Edf	08		3068	Skb	08	
2946	"	"		3069	"	"	
2947	"	"		3070	"	"	
2948	"	"		3071	"	"	
2949	"	"		3072	"	"	
3053	Skb	"		3073	"	"	
3055	"	"		3074	"	"	
3057	"	"		3075	"	"	
3059	"	"		3076	"	"	
3061	"	"		3077	"	"	
3062	"	"		3081	"	"	
3064	"	"		3083	"	"	
3065	"	"		3085	"	"	
3066	"	"		3086	"	"	
3067	"	"		3087	"	"	

Vogn nr.	Fabr.	Byggeår	Merknad	Vogn nr.	Fabr.	Byggeår	Merknad
3089	Skb	08		3142	Edf	09	
3090	"	"		3143	"	"	
3091	"	"		3144	"	"	
3092	"	"		3146	"	"	
3093	"	"		3147	"	"	
3094	"	"		3148	"	"	
3095	"	"		3150	"	"	
3096	"	"		3151	"	"	
3097	"	"		3152	"	"	
3098	"	"		3153	"	"	
3099	"	"		3155	"	"	
3100	"	"		3156	"	"	
3104	"	"		3158	"	"	
3105	"	"		3159	"	"	
3107	"	"		3160	"	"	
3108	"	"		3172	Skb	26	
3109	"	"		3173	"	"	
3110	"	"		3175	"	"	
3111	"	"		3176	"	"	
3115	"	"		3177	"	"	
3117	"	"		3178	"	"	
3118	"	"		3315	Edf	10	
3119	"	"		3316	"	"	
3120	Edf	"		3317	"	"	
3125	"	"		3318	"	"	
3126	"	"		3319	"	"	
3127	"	"		3320	"	"	
3128	"	"		3321	"	"	
3129	"	"		3323	"	"	
3130	"	"		3324	"	"	
3134	"	09		3325	"	"	
3135	"	"		3326	"	"	
3136	"	"		3327	"	"	
3137	"	"		3328	"	"	
3138	"	"		3331	"	"	

Vogn nr.	Fabr.	Byggeår	Merknad	Vogn nr.	Fabr.	Byggeår	Merknad
3332	Edf	10		3389	Skb	25	
3334	"	"		3390	"	"	
3346	"	22		3391	"	"	
3349	"	"		3394	"	"	
3351	"	"		3580	"	27	
3352	"	"		3581	"	26	
3353	"	"		3583	"	"	
3354	"	"		3584	"	"	
3355	"	"		3585	"	"	
3357	"	"		3586	"	"	
3358	"	"		3587	"	"	
3360	"	"		3588	"	"	
3361	"	"		3589	"	"	
3363	"	"		3590	"	"	
3364	"	"		3591	"	"	
3365	"	23		3592	"	"	
3367	"	"		3594	"	"	
3368	"	"		3596	"	"	
3369	"	"		3597	"	"	
3371	Skb	24		3598	"	"	
3372	"	"		3599	"	"	
3373	"	"		3600	"	"	
3374	"	"		5437	AaB	"	
3376	"	"		5438	"	"	
3377	"	"		5440	"	"	
3378	"	"		5441	"	"	
3379	"	"		5442	"	"	
3380	"	"		5443	"	"	
3381	"	"		5445	"	"	
3383	"	"		5446	"	"	
3384	"	"		5447	Skb	27	
3385	"	25		5448	"	"	
3386	"	"		5450	"	"	
3387	"	"		5452	"	"	
3388	"	"		5454	"	"	

Vogn nr.	Fabr.	Byggeår	Merknad	Vogn nr.	Fabr.	Byggeår	Merknad
5456	Skb	27		6081	Edf	09	
5457	"	"		6083	"	"	
5458	"	"		6085	"	"	
5459	"	"		6087	"	"	
5460	"	"		6089	"	"	
5461	"	"		6091	"	"	
5462	"	"		6092	"	"	
5463	"	"		6094	"	"	
5464	"	"		6096	"	"	
5466	"	"		6097	"	"	
5638	Edf	14		6099	"	"	
5639	"	"		6100	"	"	
5640	"	"		6102	"	"	
5641	"	"		6106	"	"	
5642	"	"		6109	"	"	
5643	"	"		6110	"	"	
5644	"	"		6114	"	"	
5645	"	"		8149	Skb	08	
5646	"	"		8150	"	"	
5647	"	"		8151	"	"	
5648	"	"		8153	"	"	
5649	"	"		8155	"	"	
5652	"	"		8156	"	"	
5653	"	"		8157	"	"	
5654	"	"		8158	"	"	
5656	"	"		8160	"	"	
5657	"	"		8162	"	"	
5658	"	"		8165	"	"	
5659	"	"		8166	"	"	
5660	"	"		8167	"	"	
5661	"	"		8168	"	"	
5663	"	"		8169	"	"	
5664	"	"		8170	"	"	
5665	"	"		8171	"	"	
6080	"	09		8172	"	"	

Vogn nr.	Fabr.	Byggeår	Merknad	Vogn nr.	Fabr.	Byggeår	Merknad
8173	Skb	08		8325	Str	16	
8174	Edf	09		8326	"	"	
8175	"	"		8328	"	"	
8176	"	"		8329	"	"	
8178	"	"		8330	"	"	
8179	"	"		8332	"	"	
8180	"	"		8333	"	"	
8182	"	"		8334	"	"	
8185	"	"		8335	"	"	
8186	"	"		8336	"	"	
8187	"	"		8337	"	"	
8190	"	"		8339	"	"	
8191	"	"		8340	"	"	
8193	"	"		8344	"	"	
8194	"	12		8345	"	"	
8195	"	"		8346	"	"	
8196	Str	16		8347	"	"	
8198	"	"		8348	"	"	
8199	"	"		8349	"	"	
8200	"	"		8353	Edf	"	
8290	Skb	26		8359	"	"	
8291	"	"		8361	"	"	
8293	"	"		8363	"	"	
8294	"	"		8364	"	"	
8295	"	"		8365	"	"	
8296	"	"		8367	"	"	
8298	"	"		8368	"	"	
8299	"	"		8377	Str	23	
8300	"	"		8378	"	"	
8316	Str	16		8379	"	"	
8317	"	"		8382	"	"	
8319	"	"		8384	"	"	
8320	"	"		8385	"	"	
8323	"	"		8386	"	"	
8324	"	"		8387	"	"	

Vogn nr.	Fabr.	Byggeår	Merknad	Vogn nr.	Fabr.	Byggeår	Merknad
8389	Str	23		10230	Str	23	
8390	"	"		10231	"	"	
8391	"	"		10232	"	"	
8392	"	"		10340	Edf	26	
8393	"	"		10341	"	"	
8394	"	"		10343	"	"	
8395	"	"		10344	"	"	
8396	"	"		10345	"	"	
8397	"	"		10346	"	"	
8398	"	"		10347	"	"	
8400	"	"		10349	"	"	
8401	"	"		10350	"	"	
8422	Skb	26		10352	"	"	
8423	"	"		10353	"	"	
8424	"	"		10355	"	"	
8425	"	"		10357	"	"	
8426	"	"		12171	"	15	
8427	"	"		12172	"	"	
8428	"	"		12174	"	"	
8429	"	"		12175	"	"	
8430	"	"		12176	"	"	
10208	Str	23		12177	"	"	
10209	"	"		12178	"	"	
10211	"	"		12179	"	"	
10216	"	"		14108	"	19	
10217	"	"		14109	"	"	
10218	"	"		14112	"	"	1)
10219	"	"		14113	"	"	
10220	"	"		14115	"	"	
10223	"	"		14116	"	"	
10224	"	"		14117	"	"	
10225	"	"		14118	"	"	
10226	"	"		14121	"	"	
10227	"	"		14122	"	"	
10229	"	"		14123	"	"	

1) Innredet for transport av levende fisk. V.v.=9,7t. Last = 13,0t.

Vogn nr.	Fabr.	Byggear	Merknad	Vogn nr.	Fabr.	Byggear	Merknad
14124	Edf	19		15210	Str	09	
14125	"	"		15211	Edf	"	
14126	"	"		15213	"	"	
14127	"	"		15214	"	"	
14198	Skb	24		15215	"	"	
14200	"	"	2)	15216	"	"	
14201	"	"		15217	"	"	
14203	"	"		15219	"	"	
14204	"	"		15220	"	"	
14205	"	"		15221	"	"	
14206	"	"		15222	"	"	
14207	"	"		15223	"	"	
14208	"	"		15224	"	"	
14209	"	"		15227	"	10	
14211	"	"		15230	"	"	
14212	"	"		15231	"	"	
14213	"	"		15232	"	"	
14214	"	"	3)	15233	"	"	
14215	"	"		15235	"	"	
14216	"	"		15236	"	"	
14217	"	"		15238	"	"	
14219	"	"		15240	"	"	
14220	"	"		15241	"	"	
14222	"	25		15242	"	"	
14223	"	"		15243	"	"	
14224	"	"		15244	"	"	
14225	"	"		15245	"	"	
14226	"	"		15247	"	"	
15193	Str	09		15248	"	"	
15195	"	"	4)	15258	"	20	
15197	"	"		15259	"	"	
15200	"	"		15260	"	"	
15202	"	"		15262	"	"	
15207	"	"		15263	"	"	
15208	"	"		15264	"	"	

2) Stöpt gulv. Last 13,5 t. 3) Stöpt gulv. Bæreevne 15,0 t.

4) Ballast + v.v. = 12,2 t.

Vogn nr.	Fabr.	Byggear	Merknad	Vogn nr.	Fabr.	Byggear	Merknad
15265	Edf	20		15315	Str	23	
15267	"	"		15316	"	"	
15269	Str	21		15317	"	"	
15270	"	"		15318	"	"	
15271	"	"		15319	"	"	
15273	"	"		15320	"	"	
15274	"	"		15324	"	"	
15275	"	"		15325	"	"	
15276	"	"		15327	"	"	
15277	"	"		15328	"	"	
15279	Edf	23		15355	Skb	24	
15280	"	"		15356	"	"	
15282	"	"		15358	"	"	
15283	"	"		15360	"	"	
15284	"	"		15362	"	25	
15285	"	"		15363	"	"	
15286	"	"		15364	"	"	
15287	"	"		15366	"	"	
15289	"	"		15367	"	"	
15290	"	"		15368	"	"	
15291	"	"		15369	"	"	
15293	"	"		15370	"	"	
15294	"	"		15371	"	"	
15295	"	"		15372	"	"	
15297	"	"		15374	"	"	
15298	"	"		15383	Edf	28	
15299	"	"		15384	"	"	
15301	"	"		15386	"	"	
15304	Str	"		15387	"	"	
15305	"	"		15388	"	"	
15306	"	"		15390	"	"	
15307	"	"		15391	"	"	
15309	"	"		15392	"	"	
15312	"	"		15393	"	"	
15313	"	"		15394	"	"	

Vogn nr.	Fabr.	Byggear	Merknad	Vogn nr.	Fabr.	Byggear	Merknad
15395	Edf	28		20169	Edf	22	
15396	"	"		20171	"	"	
15397	"	"		20173	"	"	
15399	"	"		20174	"	"	
15400	"	"		20176	Str	"	
15401	"	"		20177	"	"	
15402	"	"		20178	"	"	
17171	Str	21		20179	"	"	
17173	"	"		20180	"	"	
17174	"	"		20181	"	"	
17176	"	"		20182	"	"	
17180	"	"		20183	"	"	
17181	"	"		20185	"	"	
17182	"	"		20186	"	"	
17183	"	"		20189	"	"	
17501	Edf	14		20190	"	"	
17502	"	"		20191	"	"	
17503	"	"		20193	"	"	
17504	"	"		20195	"	"	
17505	"	"		20196	"	"	
17507	"	"		20197	"	"	
17508	"	"		20198	"	"	
17509	"	"		20199	"	"	
20151	"	22		20200	"	"	
20152	"	"		20775	Skb	26	
20157	"	"		20776	"	"	
20158	"	"		20777	"	"	
20159	"	"		20778	"	"	
20161	"	"		20779	"	"	
20162	"	"		20781	"	"	
20163	"	"		20782	"	"	
20164	"	"		20783	"	"	
20165	"	"		20785	"	"	
20166	"	"		20786	"	"	
20167	"	"		20787	"	"	

Vogn nr.	Fabr.	Byggeår	Merknad	Vogn nr.	Fabr.	Byggeår	Merknad
20789	Skb	26					
20792	"	"					
20793	"	"					
20794	"	"					
23075	Str	19					
23076	"	"					
23077	"	"					
23078	"	"					
23380	Skb	09					
23382	"	"					
23384	"	"					

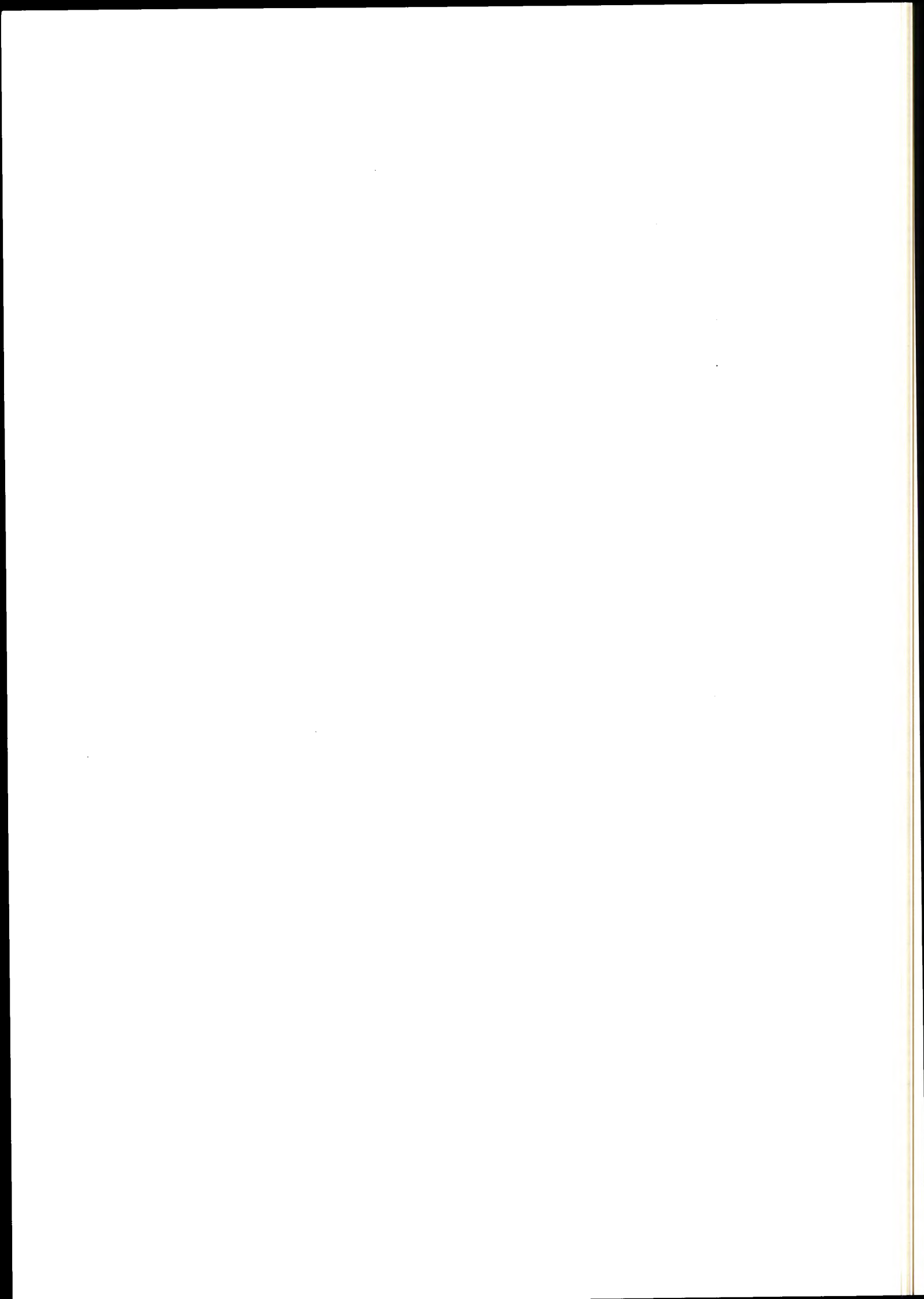

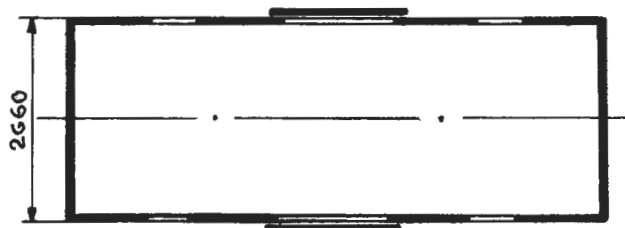
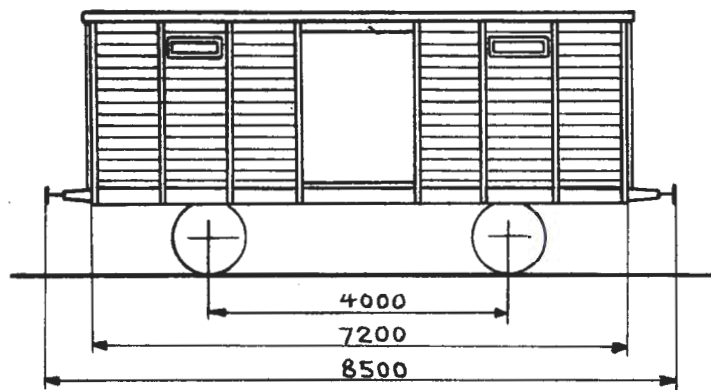

Omtrentlig vognvekt 7,5- 8,5 t
 " bæreevne 15,0-16,5 t₂
 Gulvflate 18,6 m²
 Rominnhold 37,9 m³
 Hovedtegning Vognene er innkjøpt
 fra Tyskland i 1915

LUKKET GODSVOGN

Vogn nr.	Fabr.	Byggeår	Merknad	Vogn nr.	Fabr.	Byggeår	Merknad
31028				31053			
31029				31054			
31032				31057			
31033				31058			
31034				32041			
31035				32044			
31036							
31037							
31038							
31040							
31041							
31044							
31048							
31049							
31051							

G3

TYPE 3

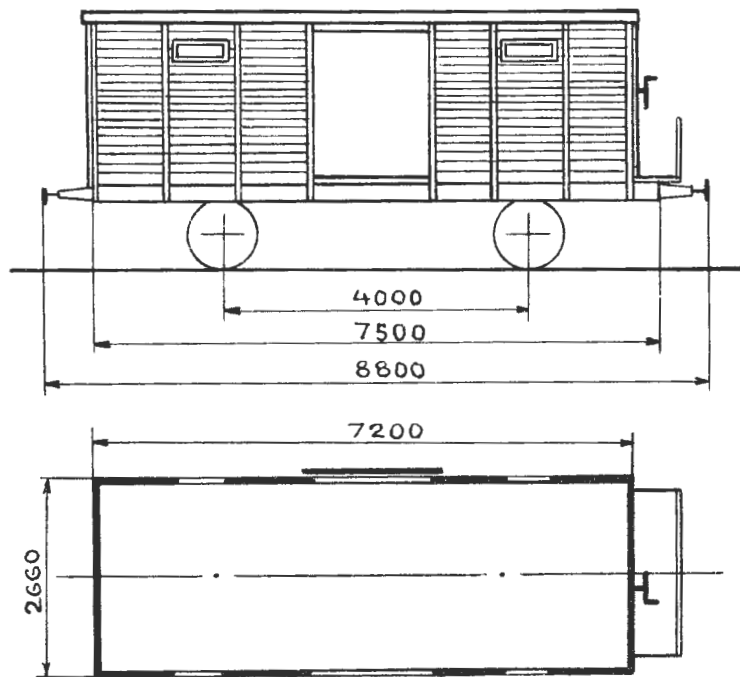

Omtrentlig vognvekt 9,0- 9,5 t
 " bæreevne 14,5-15,0 t
 Gulvflate 18,6 m²
 Rominnhold 37,9 m³
 Hovedtegning Vognene er innkjopt
 fra Tyskland i 1915

LUKKET GODSVOGN

Vogn nr.	Fabr.	Byggeår	Merknad	Vogn nr.	Fabr.	Byggeår	Merknad
31001							
31002							
31003							
31004							
31005							
31006							
31007							
31008							
31009							
31010							
31011							
31012							

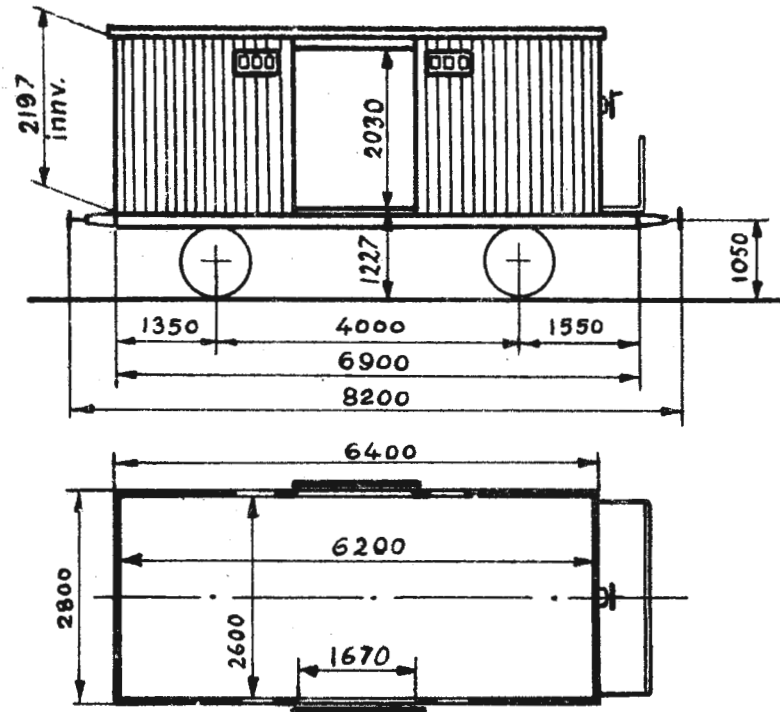

Bæreevne

A	B	C
16,0t	16,0t	

Omtrentlig vognvekt 7,5-8,5 t
 Gulvflate 16,1 m²
 Rominnhold 34,0 m³
 Hovedtegning 376 + skisse
 nr. 233

LUKKET GODSVOGN

Vogn nr.	Fabr.	Byggear	Merknad	Vogn nr.	Fabr.	Byggear	Merknad
3161	Str	19		6115	Str	21	
3164	"	"		6116	"	"	
3166	"	"		6118	"	"	
3167	"	"		6119	"	"	
3168	"	"		6120	"	"	
3169	"	"		6121	"	"	
3170	"	"		6122	"	"	
5094	Edf	16		6123	"	"	
5097	"	"		6124	"	"	
5098	"	"		6125	"	"	
5100	"	"		6126	"	"	
5667	"	15		6127	"	"	
5674	"	"		6128	"	"	
5675	"	"		6129	"	"	
5677	"	"		6288	"	19	

Vogn nr.	Fabr.	Byggear	Merknad	Vogn nr.	Fabr.	Byggear	Merknad
6289	Str	19		16553	Str	19	
6290	"	"		17154	"	"	
6291	"	"		17532	"	"	
10162	"	17		17533	"	"	
10163	"	"		17534	"	"	
10165	"	"		20754	"	"	
10166	"	"		20755	"	"	
10167	"	"		20756	"	"	
10168	"	"		20757	"	"	
10169	"	"		20758	"	"	
10170	"	"		20761	"	"	
10172	"	"		20762	"	"	
10174	"	"		23065	Skb	18	
10175	"	"		23067	"	"	
10176	"	"		23070	"	"	
10177	"	"		23074	"	"	
10178	"	"					
10181	"	"					
10182	"	"					
10185	"	"					
10187	"	"					
10188	"	"					
10189	"	"					
10190	"	"					
10198	"	19					
10199	"	"					
10201	"	"					
10202	"	"					
10206	"	"					
10207	"	"					
14090	Edf	16					
14092	"	"					
14093	"	"					
14099	"	"					
16551	Str	19					

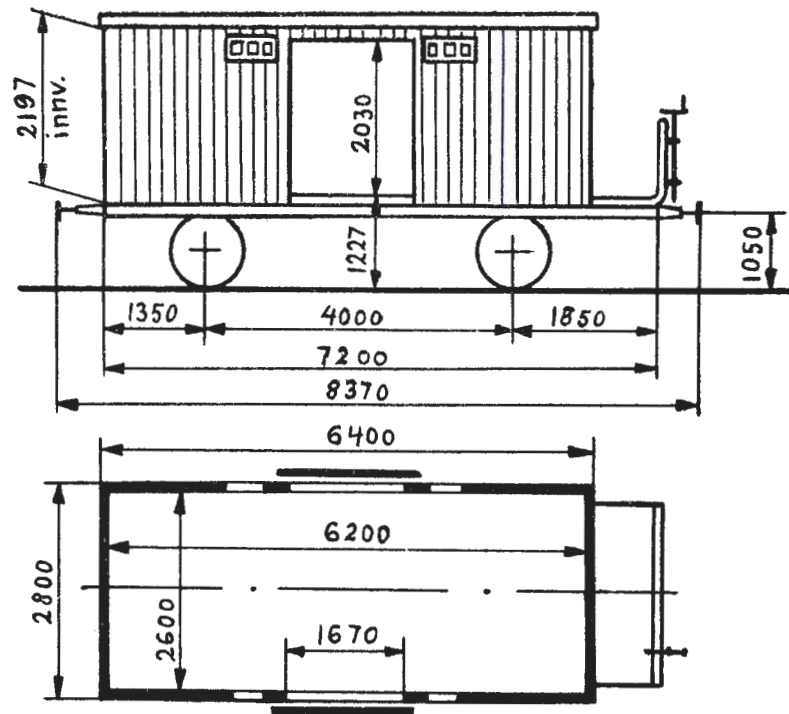

Bæreevne

A	B	C
15,5t	15,5t	

Omtrentlig vognvekt 8,0-8,5 t
 Gulvflate 16,1 m²
 Rominnhold 34,0 m³
 Hovedtegning 376 + skisse
 nr. 1085

LUKKET GODSVOGN

Vogn nr.	Fabr.	Byggeår	Merknad	Vogn nr.	Fabr.	Byggeår	Merknad
6276	Edf	09					
6278	"	"					
6281	"	"					
6283	"	"					
6286	"	"					

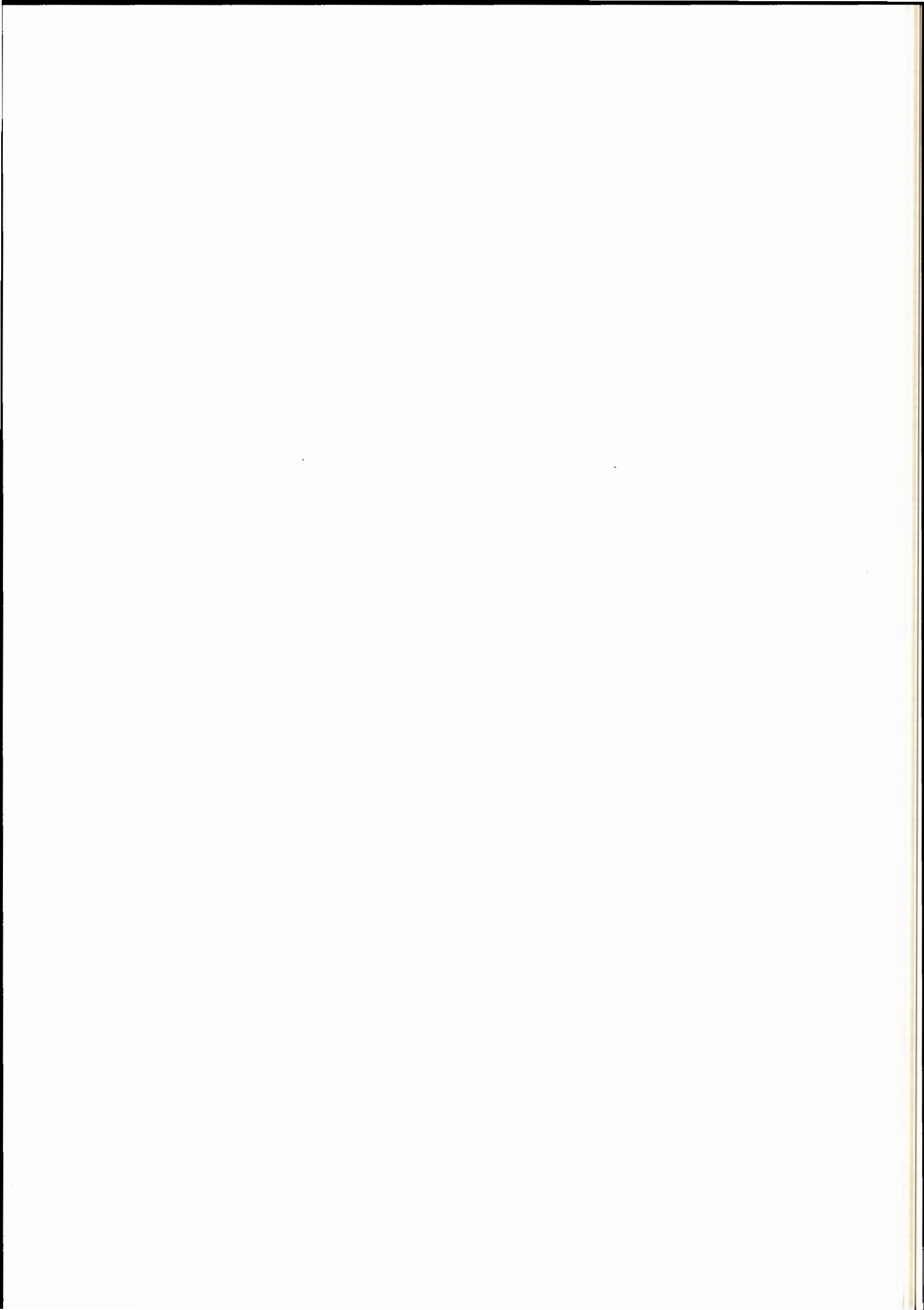

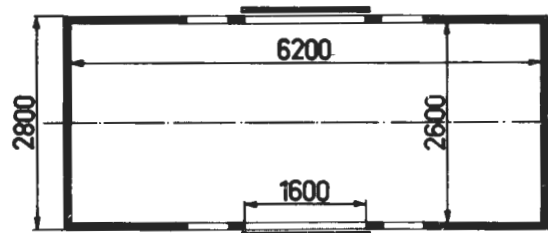
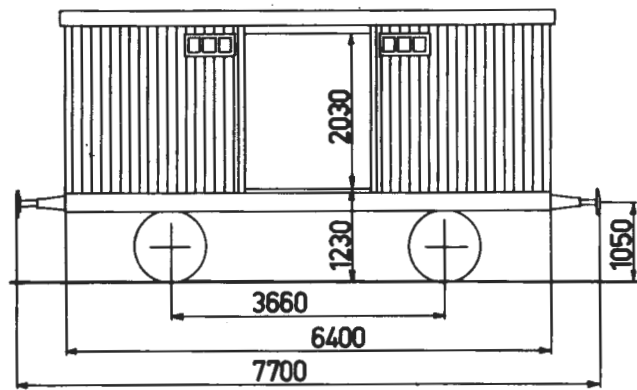

Bæreevne

A	B	C
16,0t	16,0t	

Omtrentlig vognvekt 80 t

Gulvflate 16,1 m²

Rominnhold 34,0 m³

Hovedtegning 376

LUKKET GODSVOGN

Vogn nr.	Fabr.	Byggear	Merknad	Vogn nr.	Fabr.	Byggear	Merknad
3052	Skb	08					
3106	"	"					

G4

TYPE 1

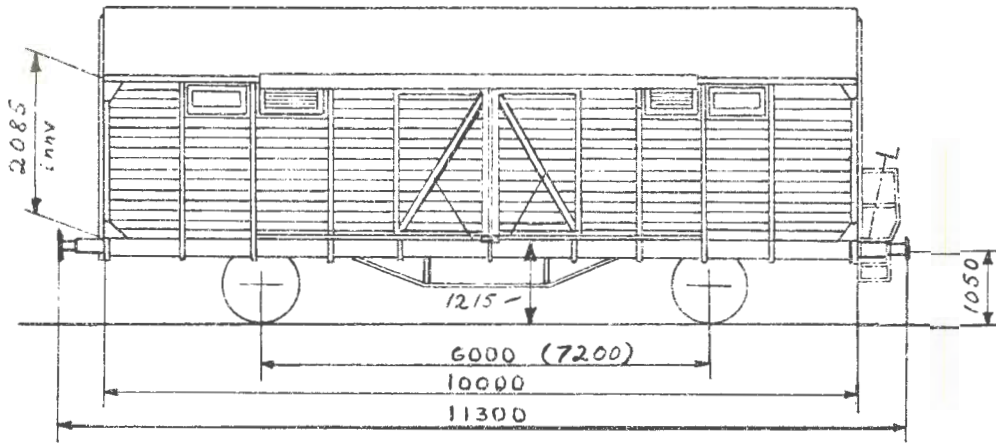

Mål i () gjelder for vogner etter h-tegn. 6475.

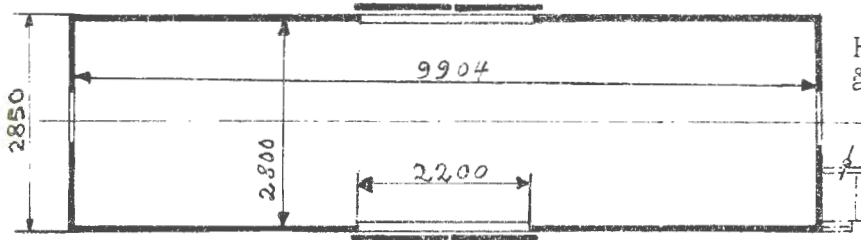

Høyde av dør-
åpning: 1927.

Bæreevne

A	B	C
18,5t	18,5t	
S	10,0t ^{x)}	

Vogner med spesial-
innredning og vogn-
vekt ca. 15,0 t, har
bæreevne 15,0 t.

Omtrentlig vognvekt 10,0-13,5 t
Gulvflate 27,7 m²
Rominnhold 58,0 m³
Hovedtegning Se merknadsrubr.

LUKKET GODSVOGN

Vogn nr.	Fabr.	Byggeår	Merknad	Vogn nr.	Fabr.	Byggeår	Merknad
			H-tegn. 3300	40014	Str	32	
40000	Str	32		40015	"	"	
40001	"	"		40016	"	"	
40002	"	"		40017	"	"	
40003	"	"		40018	"	"	1)
40004	"	"		40019	"	"	1)
40005	"	"		40020	"	"	
40006	"	"		40021	"	"	
40007	"	"		40022	"	"	
40008	"	"		40023	"	"	
40009	"	"		40024	"	"	
40010	"	"		40025	Skb	34	
40011	"	"		40026	"	"	2)
40012	"	"		40027	"	"	2)
40013	"	"		40028	"	"	2)

x) Følgende vogner har ikke S-mrk.: 40075-40109, 40112-40119, 40121, 40145-40222, 40224-40232, 40234-40255, 40257-40334, 40598-40603, 40605-40613, 40615-40632, 40658-40660, 40663, 40665, 40666, 40748-40755, 40757-40772. Vogner med rullelager har bæreevne 12,0 t som S-vogn.

1) Innredet for sykkeltransport. 2) Elektrisk lys for tilkobling til nabovogn.

Vogn nr.	Fabr.	Byggeår	Merknad	Vogn nr.	Fabr.	Byggeår	Merknad
40448	Edf	39		40482	Skb	40	.
40449	"	"	1)	40483	"	41	
40450	"	"		40484	"	"	
40451	"	"		40485	"	"	
40452	"	"		40486	"	"	
40453	"	"		40487	"	"	
40454	"	"		40488	"	"	
40455	"	"	1)	40489	"	"	
40456	"	"	1)	40490	"	"	
40457	"	"		40491	"	"	
40458	"	"		40492	"	"	
40459	"	"		40493	"	"	
40460	Skb	40		40494	"	"	
40461	"	"		40495	"	"	
40462	"	"	2)	40496	"	"	
40463	"	"		40497	"	"	
40464	"	"		40498	"	"	
40465	"	"	1)	40499	"	"	
40466	"	"		40500	"	"	
40467	"	"		40501	"	"	
40468	"	"		40502	"	"	
40469	"	"		40503	"	"	
40470	"	"		40504	"	"	
40471	"	"		40505	"	"	
40472	"	"		40506	"	"	
40473	"	"		40507	"	"	
40474	"	"		40508	"	"	
40475	"	"		40509	"	"	
40476	"	"	3)	40510	Str	41	
40477	"	"		40511	"	"	
40478	"	"		40512	"	"	
40479	"	"		40513	"	"	
40480	"	"		40514	"	"	
40481	"	"		40515	"	"	

1) Innredet for sykkeltransport. 2) Innredet for syketransport.
3) Elektr. lys for tilkobl. til nabovogn. Dør og overgangslem i den ene vognende.

Vogn nr.	Fabr.	Byggear	Merknad	Vogn nr.	Fabr.	Byggear	Merknad
40516	Str	41		40551	Str	41	
40517	"	"		40552	"	"	
40518	"	"		40553	"	"	
40519	"	"		40554	"	"	
40520	"	"		40555	"	"	
40521	"	"		40556	"	"	
40522	"	"		40557	"	"	
40523	"	"		40558	"	"	
40524	"	"		40559	"	"	
40525	"	"		40560	"	"	
40526	"	"		40561	"	"	
40527	"	"		40562	"	"	
40528	"	"		40563	"	"	
40529	"	"	1)	40564	"	"	
40530	"	"		40565	"	"	
40531	"	"		40566	"	"	
40532	"	"		40567	"	"	
40533	"	"		40568	"	"	
40534	"	"		40569	"	"	
40535	"	"		40570	"	"	
40536	"	"		40571	"	"	
40537	"	"		40572	"	"	
40538	"	"		40573	"	"	
40539	"	"		40574	"	"	
40540	"	"		40575	"	"	
40541	"	"	1) 2)	40576	"	"	
40542	"	"		40577	"	"	
40543	"	"		40578	"	"	
40544	"	"		40579	"	"	
40545	"	"		40580	"	"	
40546	"	"	1)	40581	"	"	
40547	"	"		40582	"	"	
40548	"	"		40583	"	"	
40549	"	"		40584	"	"	
40550	"	"					

1) Innredet for sykkeltransport. 2) Akselavstand forandret til 7,2 m.

Vogn nr.	Fabr.	Byggeår	Merknad	Vogn nr.	Fabr.	Byggeår	Merknad
40725	Edf	41		40760	Edf	42	
40726	"	"		40761	"	"	
40727	"	"		40762	"	"	
40728	"	"	1)	40763	"	"	
40729	"	"		40764	"	"	
40730	"	"		40765	"	"	
40731	"	"		40766	"	"	
40732	"	"		40767	"	"	
40733	"	"		40768	"	"	
40734	"	"		40769	"	"	
40735	"	"		40770	"	"	
40736	"	42		40771	"	"	
40737	"	"		40772	"	"	
40738	"	"		40773	"	"	
40739	"	"		40774	"	"	
40740	"	"		40776	"	"	
40741	"	"		40777	"	"	
40742	"	"		40778	"	"	
40743	"	"		40779	"	"	
40744	"	"		40780	"	"	
40745	"	"		40781	"	43	
40746	"	"		40782	"	"	
40747	"	"		40783	"	"	
40748	"	"		40784	"	"	
40749	"	"		40785	"	"	
40750	"	"		40786	"	"	
40751	"	"		40787	"	"	
40752	"	"		40788	"	"	
40753	"	"		40789	"	"	
40754	"	"		40790	"	"	
40755	"	"		40791	"	"	
40756	"	"		40792	"	"	
40757	"	"		40793	"	"	
40758	"	"		40794	"	"	
40759	"	"		40795	"	"	

1) Innredet for sykkeltransport.

Trykk nr. 752 1.7.57

Vogn nr.	Fabr.	Byggear	Merknad	Vogn nr.	Fabr.	Byggear	Merknad
40796	Edf	43		40830	Edf	43	
40797	"	"		40831	"	"	
40798	"	"		40832	"	"	
40799	"	"		40833	"	"	
40800	"	"		40834	"	"	
40801	"	"		40835	"	"	
40802	"	"		40836	"	"	
40803	"	"		40837	"	"	
40804	"	"		40838	"	"	
40805	"	"		40839	"	44	
40806	"	"		40840	"	"	
40807	"	"		40841	"	"	
40809	"	"		40842	"	"	
40810	"	"		40843	"	"	
40811	"	"		40844	"	"	
40812	"	"		40845	"	"	1)
40813	"	"		40846	"	"	
40814	"	"		40847	"	"	
40815	"	"		40848	"	"	
40816	"	"		40849	"	"	
40817	"	"		40850	"	"	
40818	"	"		40851	"	"	
40819	"	"		40852	"	"	1)
40820	"	"		40853	Skb	43	
40821	"	"		40854	"	"	
40822	"	"		40855	"	"	
40823	"	"		40856	"	"	
40824	"	"		40857	"	"	
40825	"	"		40858	"	"	
40826	"	"		40859	"	"	
40827	"	"		40860	"	"	
40828	"	"		40861	"	"	
40829	"	"		40862	"	"	

1) Elektr. lys for tilkobl. til nabovg. Dør og overgangslem i den ene vognende.

G4
TYPE 2

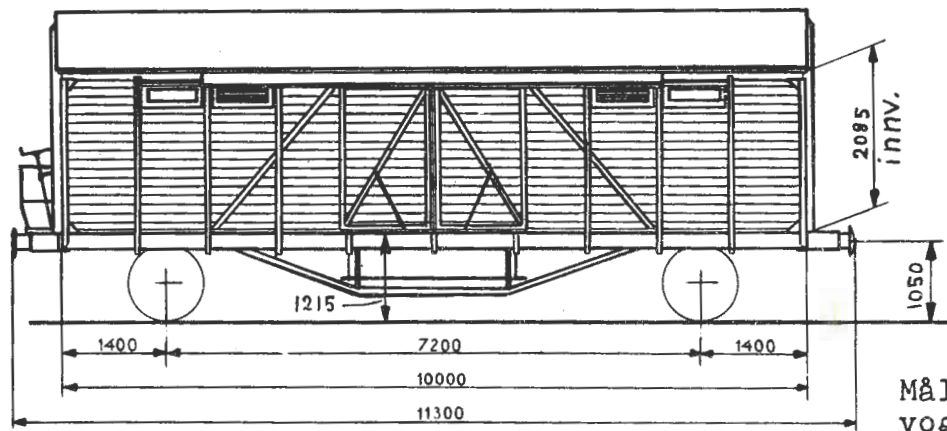

Mål i () gjelder for vogn nr. 42002.

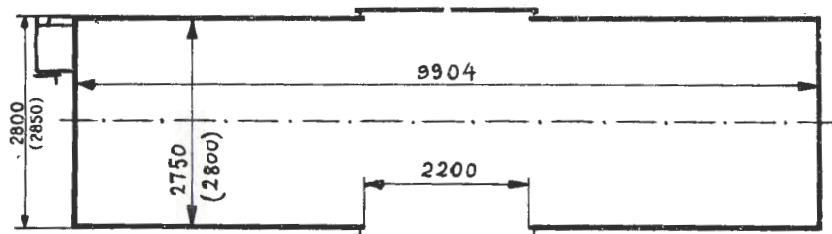

Høyde av dør-
åpning: 1927

Bæreevne

	A	B	C
	18,0t	18,0t	
S	12,0t		

Omtrentlig vognvekt 11,5-14,0 t₂
 Gulvflate 27,2 m²
 Rominnhold 57,0 m³
 Hovedtegning 6475 eller 6882

LUKKET GODSVOGN

Vogn nr.	Fabr.	Byggeår	Merknad	Vogn nr.	Fabr.	Byggeår	Merknad
42002	Edf	53	H-tegn. 6475 ¹⁾	42016	Edf	53	
				42017	"	"	
				42018	"	"	
42005	Edf	53	H-tegn. 6882	42019	"	"	
42006	"	"		42020	"	"	
42007	"	"		42021	"	"	
42008	"	"		42022	"	"	
42009	"	"		42023	"	"	
42010	"	"		42024	"	"	
42011	"	"		42025	"	"	
42012	"	"		42026	"	"	
42013	"	"		42027	"	"	
42014	"	"		42028	"	"	
42015	"	"					

1) Med forandring etter tegn. 6871 + 6879. Rominnhold 58,6 m³.

G4
TYPE 2

Vogn nr.	Fabr.	Byggear	Merknad	Vogn nr.	Fabr.	Byggear	Merknad
42029	Edf	53		42068	Skb	53	
42030	Skb	"		42069	"	"	
42031	"	"		42070	"	"	
42032	"	"		42071	"	"	
42033	"	"		42072	"	"	
42034	"	"		42073	"	"	
42035	"	"		42074	"	"	
42036	"	"		42075	"	"	
42037	"	"		42076	"	"	
42038	"	"		42077	"	"	
42039	"	"	1)	42078	"	"	
42040	"	"		42079	"	"	
42041	"	"		42080	"	"	
42042	"	"		42081	"	"	
42043	"	"		42082	"	"	
42044	"	"		42083	"	"	
42045	"	"		42084	"	"	
42046	"	"		42085	"	"	
42047	"	"		42086	"	54	
42048	"	"		42087	"	"	
42049	"	"		42088	"	"	
42050	"	"		42089	"	"	
42051	"	"		42090	"	"	
42052	"	"		42091	"	"	
42053	"	"		42092	"	"	
42054	"	"		42093	"	"	
42055	"	"		42094	"	"	
42056	"	"		42095	"	"	
42057	"	"		42096	"	"	
42058	"	"		42097	"	"	
42059	"	"		42098	"	"	
42060	"	"		42099	"	"	
42061	"	"		42100	"	"	
42062	"	"		42101	"	"	
42063	"	"		42102	"	"	
42064	"	"		42103	"	"	
42065	"	"		42104	"	"	
42066	"	"					
42067	"	"					

1) Elektr. lys for tilkobl. til nabovg.

Vogn nr.	Fabr.	Byggeår	Merknad	Vogn nr.	Fabr.	Byggeår	Merknad
43402	Hök	60					
43403	"	"					
43404	"	"					
43405	"	"					
43406	"	"					
43407	"	"					
43408	"	"					
43409	"	"					

G 5

TYPE 3

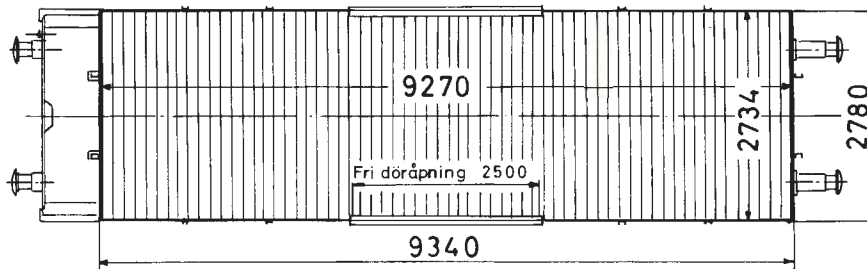
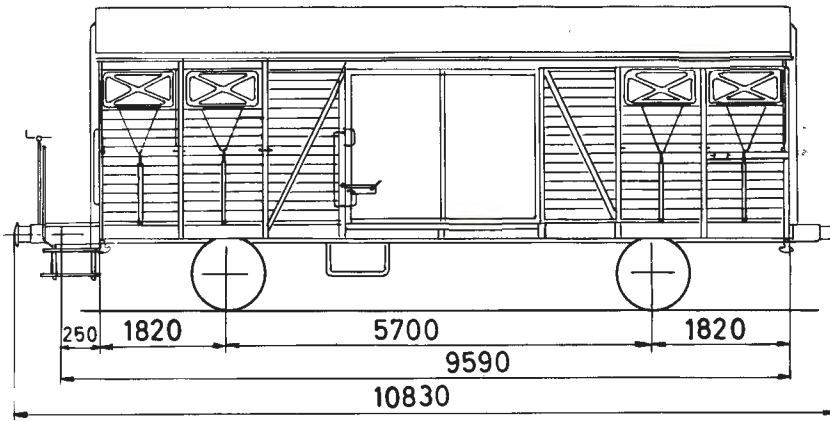

Bæreevne

	A	B	C
	19,5t	23,5t	27,5t
S	19,5t	23,5t	

Omtrentlig vognvekt 12,0 t

Gulvflate 25,3 m²

Rominhold 64,0 m³

Hovedtegning 12994

LUKKET GODSVOGN

Vogn nr.	Fabr.	Byggeår	Merknad	Vogn nr.	Fabr.	Byggeår	Merknad
43410	Str	63		43424	Str	63	
43411	"	"		43425	"	"	
43412	"	"		43426	"	"	
43413	"	"		43427	"	"	
43414	"	"		43428	"	"	
43415	"	"		43429	"	"	
43416	"	"		43430	"	"	
43417	"	"		43431	"	"	
43418	"	"		43432	"	"	
43419	"	"		43433	"	"	
43420	"	"		43434	"	"	
43421	"	"		43435	"	"	
43422	"	"		43436	"	"	
43423	"	"		43437	"	"	

Vogn nr.	Fabr.	Byggeår	Merknad	Vogn nr.	Fabr.	Byggeår	Merknad
43438	Str	63		43473	Str	63	
43439	"	"		43474	"	"	
43440	"	"		43475	"	"	
43441	"	"		43476	"	"	
43442	"	"		43477	"	"	
43443	"	"		43478	"	"	
43444	"	"		43479	"	"	
43445	"	"		43480	"	"	
43446	"	"		43481	"	"	
43447	"	"		43482	"	"	
43448	"	"		43483	"	"	
43449	"	"		43484	"	"	
43450	"	"		43485	"	"	
43451	"	"		43486	"	"	
43452	"	"		43487	"	"	
43453	"	"		43488	"	"	
43454	"	"		43489	"	"	
43455	"	"		43490	"	"	
43456	"	"		43491	"	"	
43457	"	"		43492	"	"	
43458	"	"		43493	"	"	
43459	"	"		43494	"	"	
43460	"	"		43495	"	"	
43461	"	"		43496	"	"	
43462	"	"		43497	"	"	
43463	"	"		43498	"	"	
43464	"	"		43499	"	"	
43465	"	"		43500	"	"	
43466	"	"		43501	"	"	
43467	"	"		43502	"	"	
43468	"	"		43503	"	"	
43469	"	"		43504	"	"	
43470	"	"		43505	"	"	
43471	"	"		43506	"	"	
43472	"	"		43507	"	"	

Vogn nr.	Fabr.	Byggear	Merknad	Vogn nr.	Fabr.	Byggear	Merknad
43508	Str	63		43543	Str	63	
43509	"	"		43544	"	"	
43510	"	"		43545	"	"	
43511	"	"		43546	"	"	
43512	"	"		43547	"	"	
43513	"	"		43548	"	"	
43514	"	"		43549	"	"	
43515	"	"		43550	"	"	
43516	"	"		43551	"	"	
43517	"	"		43552	"	"	
43518	"	"		43553	"	"	
43519	"	"		43554	"	"	
43520	"	"		43555	"	"	
43521	"	"		43556	"	"	
43522	"	"		43557	"	"	
43523	"	"		43558	"	"	
43524	"	"		43559	"	"	
43525	"	"		43560	"	"	
43526	"	"		43561	"	"	
43527	"	"					
43528	"	"					
43529	"	"					
43530	"	"					
43531	"	"					
43532	"	"					
43533	"	"					
43534	"	"					
43535	"	"					
43536	"	"					
43537	"	"					
43538	"	"					
43539	"	"					
43540	"	"					
43541	"	"					
43542	"	"					

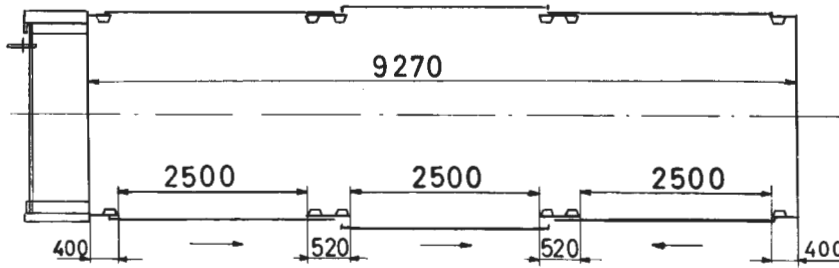
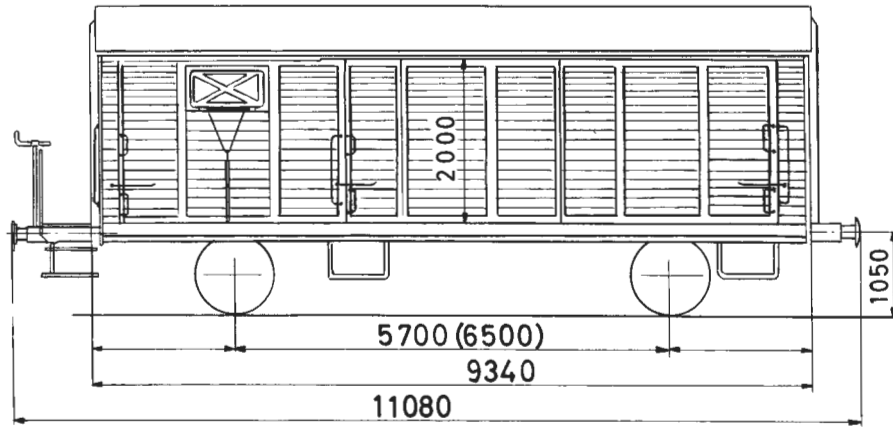

Bæreevne

	A	B	C
	20,0t	23,5t	27,5t
S	20,0t	23,5t	

Omtrentlig vognvekt	12,5 t
Gulvflate	25,3m ²
Rominhold	64,0m ³
Hovedtegning	1-48920

LUKKET GODSVOGN

Vogn nr.	Fabr.	Byggeår	Merknad	Vogn nr.	Fabr.	Byggeår	Merknad
44000	Str	62	1)				
44001	"	"	1)				

1) Bygget som prøvevogn.

Gf2
TYPE 1

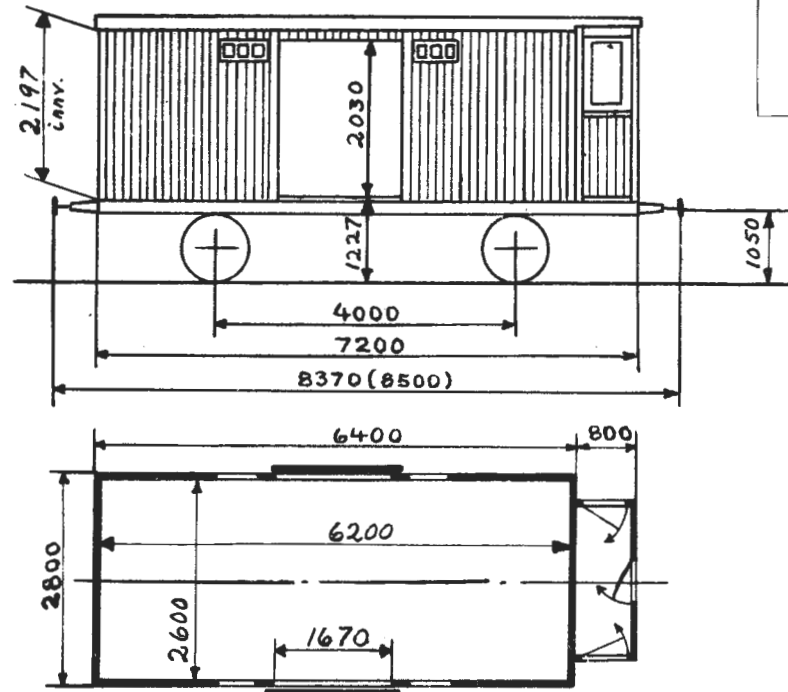

Omtrentlig vognvekt 7,5- 8,5 t
 " bæreevne 9,5-10,5 t
 Gulvflate 16,1 m²
 Rominnhold 34,0 m³
 Hovedtegning 376 + 387

LUKKET GODSVOGN

Vogn nr.	Fabr.	Byggeår	Merknad	Vogn nr.	Fabr.	Byggeår	Merknad
6266	Str	98					
8116	Skb	99					

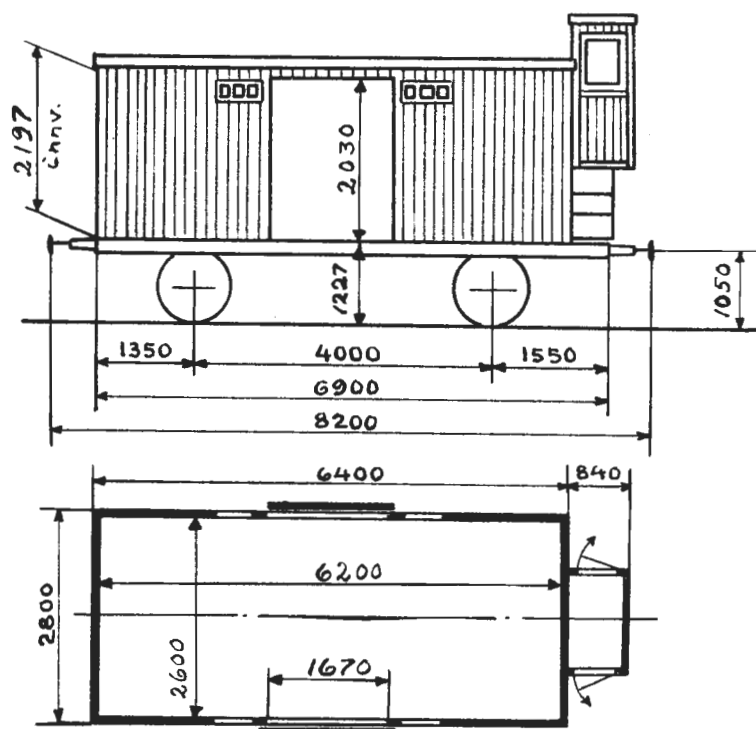

Omtrentlig vognvekt 8,0 t
 " bæreevne 10,5 t
 Gulvflate 16,1 m²
 Rominnhold 34,0 m³
 Hovedtegning 376 + bremserhus

LUKKET GODSVOGN

Vogn nr.	Fabr.	Byggeår	Merknad	Vogn nr.	Fabr.	Byggeår	Merknad
2056	Skb	10					
2848	"	"					
14077	Edf	"					

Gf 3

TYPE 1

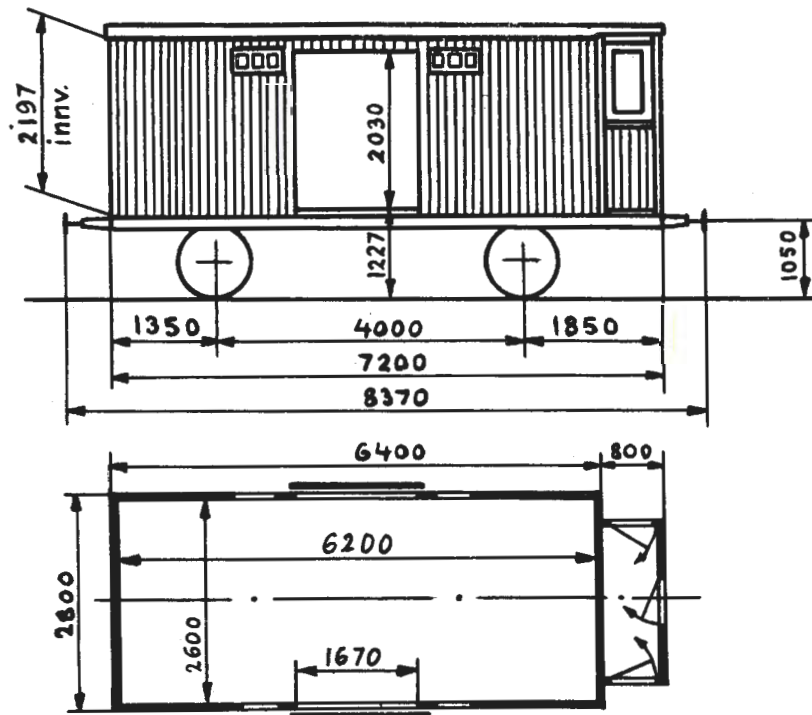

Omtrentlig vognvekt	8,0-8,5 t
" bæreevne	15,5 t
Gulvflate	16,1 m ²
Rominnhold	34,0 m ³
Hovedtegning	376 + 387

LUKKET GODSVOGN

Vogn nr.	Fabr.	Byggeår	Merknad	Vogn nr.	Fabr.	Byggeår	Merknad
6284	Edf	09					
6285	"	"					

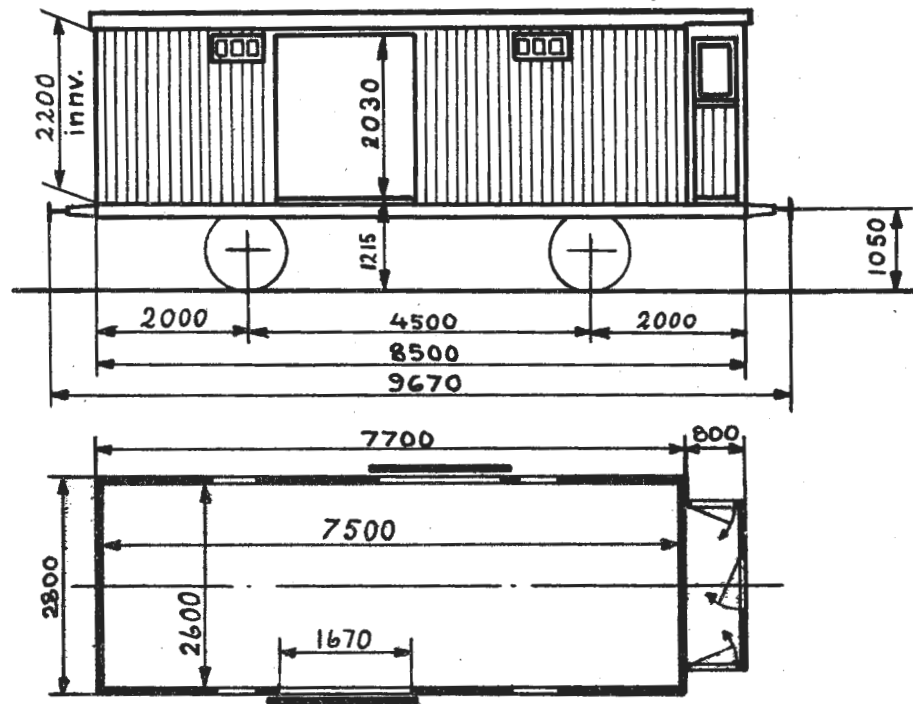

Omtrentlig egenvekt 9,5 t
 " " last 13,5 t
 Gulvflate 19,6 m²
 Rominnhold 41,1 m³
 Hovedtegning 648

LUKKET GODSVOGN

Vogn nr.	Fabr.	Byggear	Merknad	Vogn nr.	Fabr.	Byggear	Merknad
13011	Str	02					
13012	"	"					
13013	"	"					
13014	"	"					
13015	"	"					
13016	"	"					
13017	"	"					
13018	"	"					
13019	"	"					
13020	"	"					

Gf3

TYPE 3

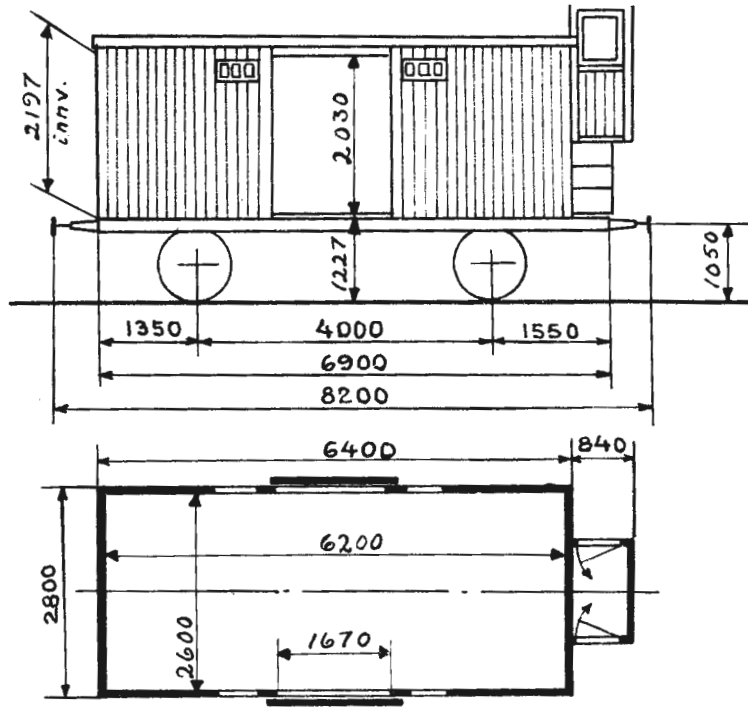

Bæreevne

A	B	C
15,5t	15,5t	

Omtrentlig vognvekt 8,5 t
 Gulvflate 16,1 m²
 Rominnhold 34,0 m³
 Hovedtegning 376 + bremserhus

LUKKET GODSVOGN

Vogn nr.	Fabr.	Byggeår	Merknad	Vogn nr.	Fabr.	Byggeår	Merknad
5095	Edf	16					
10180	Str	17					
10184	"	"					
10198	"	19					
14098	Edf	16					
23071	Skb	18					

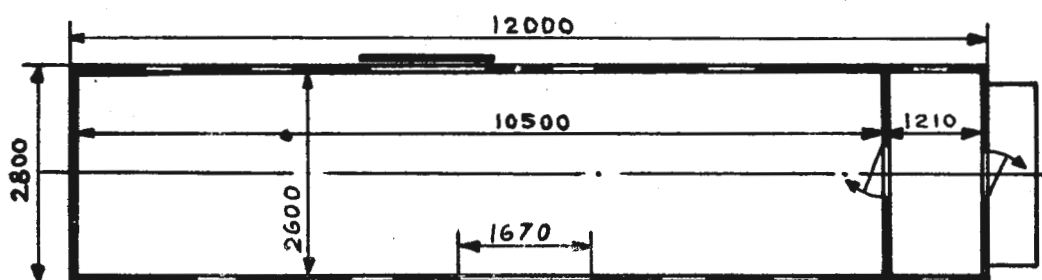
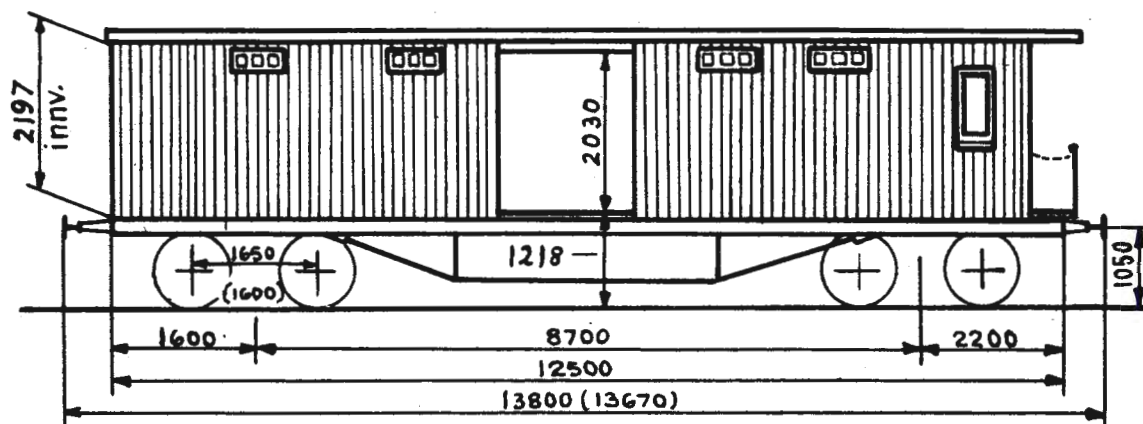

Grunnriss 1

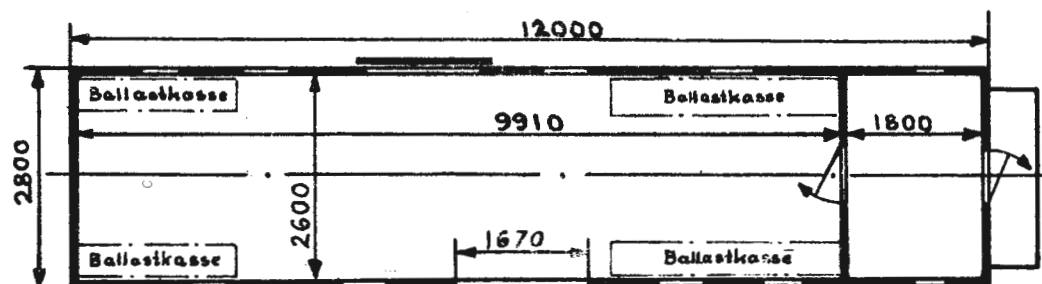

Grunnriss 2

Omtrentlig vognvekt 15,5-16,0 t
 " last + ballast 19,0 t
 Gulvflate 27,3 m² 1) 25,8 m² 2)
 Rominnhold 57,8 m³ 1) 56,8 m³ 2)
 Hovedtegning 770

LUKKET GODSVOGN

Vogn nr.	Fabr.	Byggeår	Merknad	Vogn nr.	Fabr.	Byggeår	Merknad
6201	Str	05	2)	10194	Str	17	2) 3)
6202	"	"	2) 3)	10196	"	19	1)
6206	"	17	1)	12181	"	17	1)
6210	"	18	2) 3)	12182	"	"	2) 3)
10191	"	17	1) 3)	14100	"	16	1)
				14101	"	"	2) 3)
				14102	"	"	1) 4)

1) Grunnriss 1. 2) Grunnriss 2. 3) Har ballast. 4) Benyttes som ren godsvogn. Dør mellom konduktør- og godsrom er gjenpanelt.

Vogn nr.	Fabr.	Byggeår	Merknad	Vogn nr.	Fabr.	Byggeår	Merknad
14103	Str	16	2)				
14105	"	"	1)				
15251	"	18	2) 4)				
15257	"	19	2) 3)				
20764	"	"	2) 4)				

1) Grunnriss 1. 2) Grunnriss 2. 3) Har ballast. 4) Benyttes som ren godsvogn. Dør mellom konduktør- og godsrom er gjenpanelt.

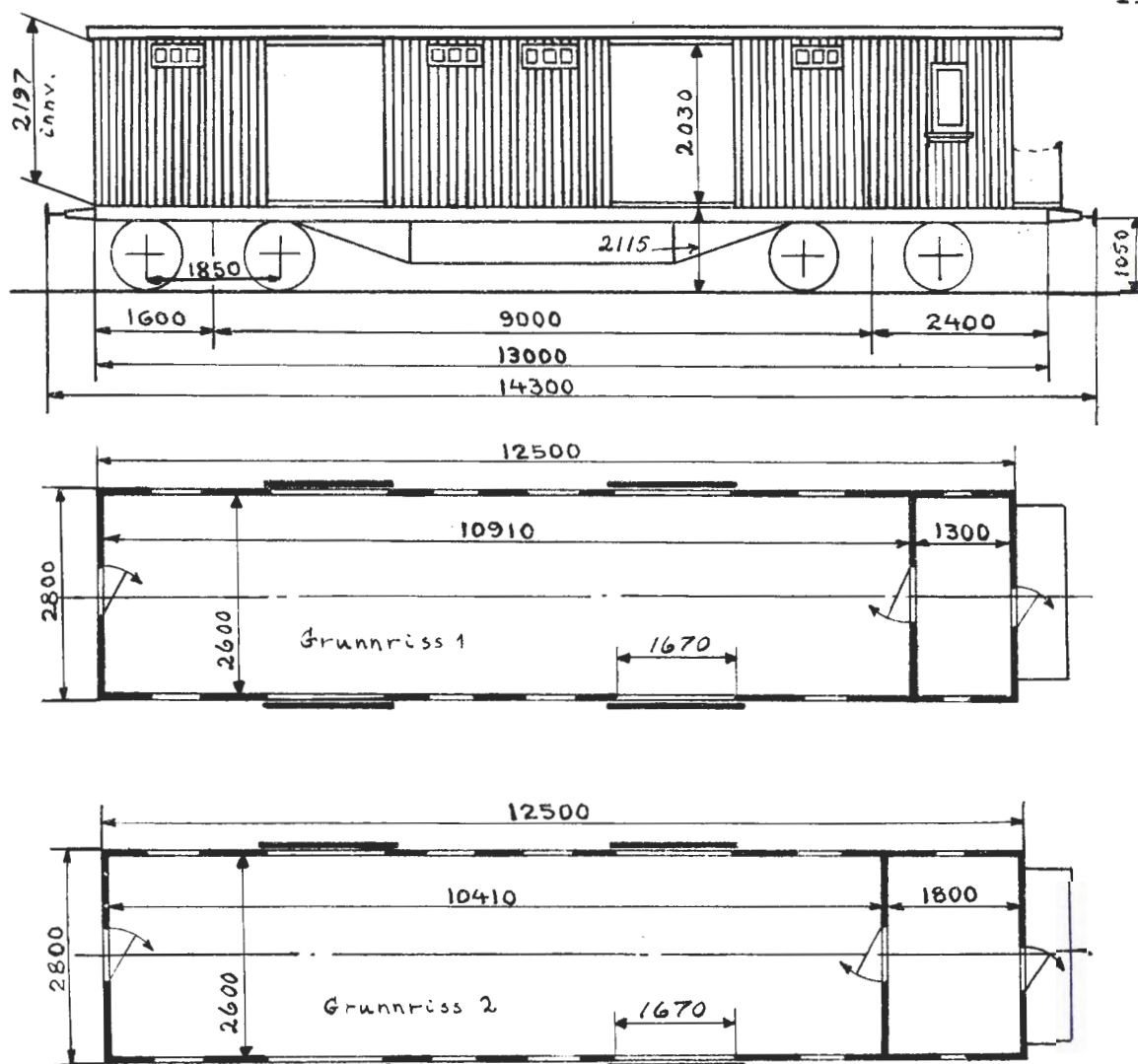

Omtrentlig vognvekt 16,0-17,5 t
 " last + ballast 17,0 t
 Gulvflate 28,4 m² 1) 27,1 m² 2)
 Rominnhold 60,4 m³ 1) 57,6 m³ 2)
 Hovedtegning 2633

LUKKET GODSVOGN

Vogn nr.	Fabr.	Byggeår	Merknad	Vogn nr.	Fabr.	Byggeår	Merknad
3335	Skb	23	2) 4)	3342	Skb	23	2) 4)
3336	"	"	2)	3343	"	"	2) 4)
3337	"	"	2)	3344	"	"	2)
3339	"	"	2)	5149	"	"	2)
3340	"	"	2) 4)	5151	"	"	2) 3)
3341	"	"	2) 4)	5152	"	"	2)

1) Grunnriss 1. 2) Grunnriss 2. 3) Har ballast. 4) Benyttes som ren godsvoan. Dør mellom konduktør- og godsrom, samt endedør i godsrom er gjenpanelt.

Vogn nr.	Fabr.	Byggeår	Merknad	Vogn nr.	Fabr.	Byggeår	Merknad
5702	Skb	23	2) 3)				
5703	"	"	2) 4)				
5704	"	"	2)				
5707	"	"	2)				
5708	"	"	2) 4)				
5711	"	"	1) 3)				
5712	"	"	1) 3)				
5713	"	"	2) 4)				
5714	"	"	2) 4)				
14129	"	"	2) 3)				
14130	"	"	2) 4)				
14131	"	"	2)				
14132	"	"	2)				
14133	"	"	2)				
14134	"	"	2) 4)				
14135	"	"	2)				
14136	"	"	2) 4)				

1) Grunnriss 1. 2) Grunnriss 2. 3) Har ballast. 4) Benyttes som ren godsvogn. Dør mellom konduktør- og godsrom, samt endedør i godsrom er gjenpanelt.

Gfo2

TYPE 3

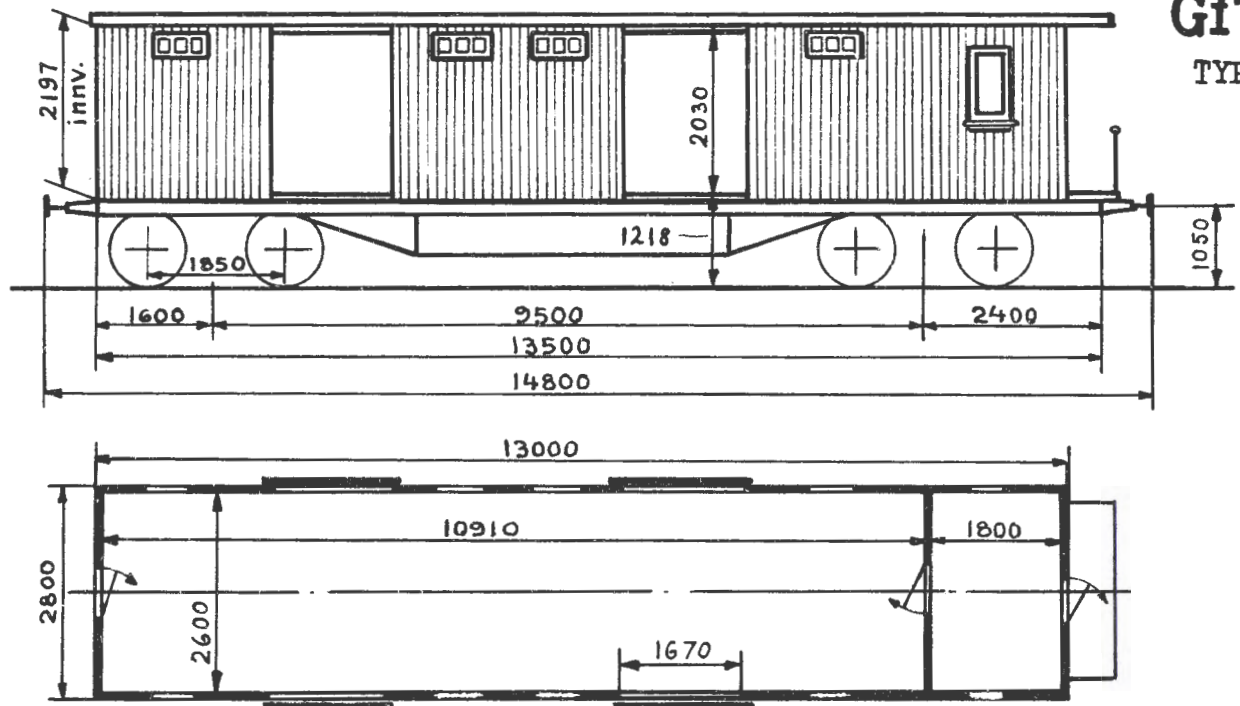

Omtrentlig vognvekt	16,5-17,5	t
" bæreevne	17,5-19,0	t
Gulvflate	27,1-28,4	m ²
Rominnhold	57,6-60,4	m ³
Hovedtegning	2898	

LUKKET GODSVOGN

Vogn nr.	Fabr.	Byggeår	Merknad	Vogn nr.	Fabr.	Byggeår	Merknad
3397	Str	25		14138	Str	26	
3399	"	"		14139	"	"	2)
3402	"	"	1)	14140	"	"	
3403	"	"		14143	"	"	
3404	"	"	2)	14144	"	"	2)
3405	Skb	28	1)	14145	"	"	
3408	"	29		14146	"	"	2)
3409	"	"		15376	"	25	2)
10233	Str	25	2)	15377	"	"	2)
10236	"	"		15378	"	"	1)
10237	"	"		15382	"	"	
10239	"	"		15403	Edf	32	2)
10240	"	"	2)	15404	"	"	
10242	"	"	2)	15405	"	"	2)
10243	"	"	2)	15406	"	"	
				15407	"	"	

1) Har ballast. 2) Benyttes som ren godsvogn. Dør mellom konduktør- og godsrom, samt endedør i godsrom er gjenpanelt.

Trykk nr. 752 1.1.64

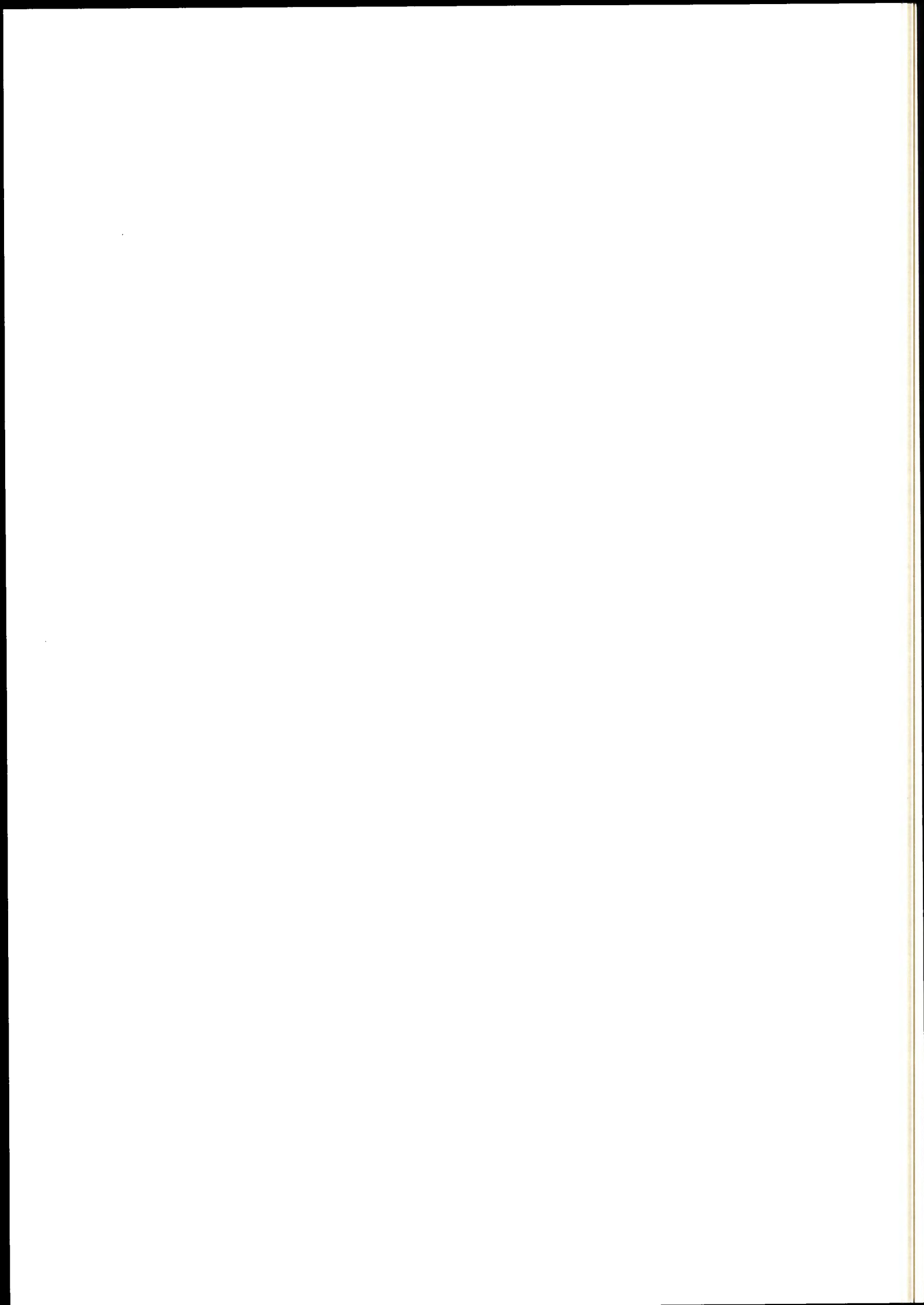

Vogn nr.	Fabr.	Byggeår	Merknad	Vogn nr.	Fabr.	Byggeår	Merknad
48028	Skb	52					
48029	"	"					
48030	"	"					
48031	"	"					
48032	"	"					
48033	"	"					
48034	"	"					
48035	"	53					
48036	"	52					
48037	"	"					
48038	"	"					
48039	"	"					
48040	"	51					
48041	"	"					
48042	"	52					
48043	"	53					
48044	"	52					
48045	"	50					
48046	"	53					
48047	"	51					
48048	"	53					
48049	"	51					

Gp4

TYPE 1

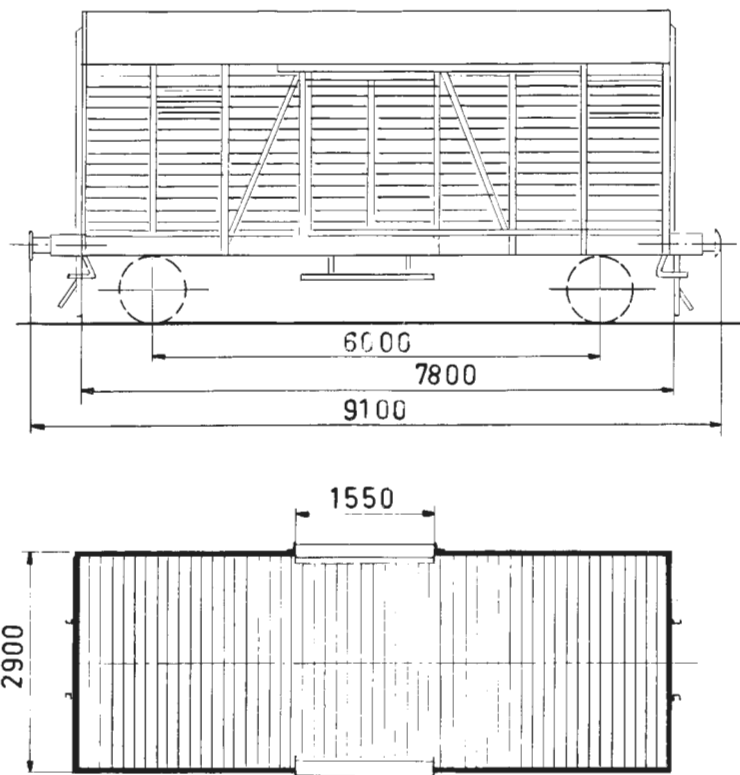

Bæreevne

	A	B	C
	16,0t	16,0t	
S	12,0t		

Omtrentlig vognvekt 10,5-12,5t

Gulvflate 21,2-21,3 m²

Rominnhold 44,5-45,7 m³

Hovedtegning ukjent

LUKKET GODSVOGN

Vogn nr.	Fabr.	Byggeår	Merknad	Vogn nr.	Fabr.	Byggeår	Merknad
33100	WM	42		33114	JR	41	
33101	Sim	39		33115	WM	40	
33102	WD	41		33116	JR	"	
33103	GL	"		33117	Sim	38	
33104	WD	"		33118	LH	39	
33105	Lut	"		33119	1) 2)		
33106	Sim	38		33120	GL	42	
33107	GL	41		33121	"	43	
33108	Sim	42		33122	WAg	41	3)
33109	WM	40		33123	WD	38	
33110	1)	39		33124	WAg	43	
33111	1)	2)		33125	GL	42	
33112	LH	35		33126	WD	39	
33113	1)	2)		33127	"	41	

1) Vognfabrikant ukjent, til nabovogn.

2) Byggeår ukjent, 3) Elektrisk lys for tilkobling

Trykk nr.752 1.1.64

Vogn nr.	Fabr.	Byggeår	Merknad	Vogn nr.	Fabr.	Byggeår	Merknad
33128	GL	43					
33129	"	42					
33130	BWM	"					
33131	WM	43					
33132	Sim	42					
33133	GL	"					
33134	GWA	"					
33135	GL	43					
33136	Sim	"					
33137	WD	41					
33138	WM	42					
33139	NW	14					
33140	JR	41					
33141	WM	2)					
33142	"	41					
33143	WAg	42 3)					
33144	GL	"					
33145	WM	40 3)					
33146	BWM	" 3)					
33147	WD	"					
33148	Sim	43 3)					
33149	GL	42 3)					
33150	WAg	"					
33151	WD	40 3)					
33152	Sim	43 3)					
33153	GL	41 3)					
33154	BWM	42 3)					
33155	Sim	"					
33156	NW	"					
33157	GWA	41					
33158	WAg	42					
33159	GL	"					
33160	WAR	41					
34900	BWM	42					
34901	"	"					

2) Byggeår ukjent. 3) Har ballast.

Gr 5
TYPE 1

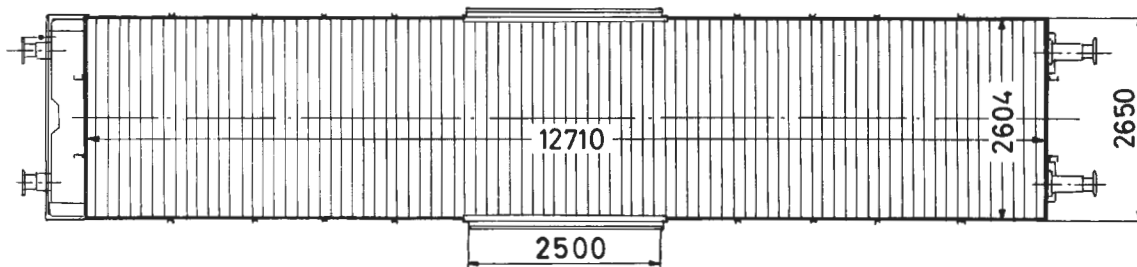
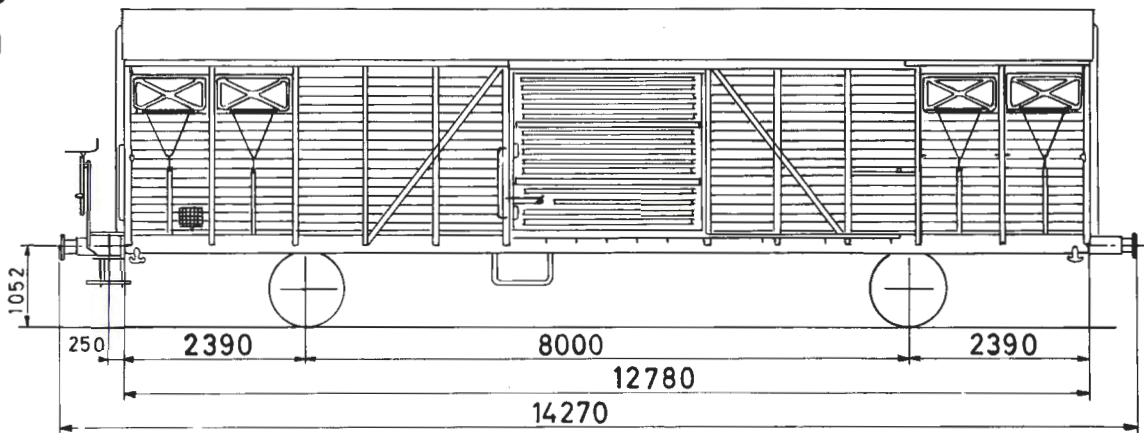

Bæreevne

	A	B	C
	18,0t	22,0t	26,0t
S	18,0t	22,0t	

Omtrentlig vognvekt	14,0 t
Gulvflate	33,0 m ²
Rominnhold	83,0 m ³
Hovedtegning	13500

LUKKET GODSVOGN

Vogn nr.	Fabr.	Byggeår	Merknad	Vogn nr.	Fabr.	Byggeår	Merknad
46000	Hök	63		46014	Hök	63	
46001	"	"		46015	"	"	
46002	"	"		46016	"	"	
46003	"	"		46017	"	"	
46004	"	"		46018	"	"	
46005	"	"		46019	"	"	
46006	"	"		46020	"	"	
46007	"	"		46021	"	"	
46008	"	"		46022	"	"	
46009	"	"		46023	"	"	
46010	"	"		46024	"	"	
46011	"	"		46025	"	"	
46012	"	"		46026	"	"	
46013	"	"		46027	"	"	

Vogn nr.	Fabr.	Byggesår	Merknad	Vogn nr.	Fabr.	Byggesår	Merknad
46028	Hök	63		46063	Hök	63	
46029	"	"		46180	Hök/ Edf	"	
46030	"	"		46181	"	"	
46031	"	"		46182	"	"	
46032	"	"		46183	"	"	
46033	"	"		46184	"	"	
46034	"	"		46185	"	"	
46035	"	"		46186	"	"	
46036	"	"		46187	"	"	
46037	"	"		46188	"	"	
46038	"	"		46189	"	"	
46039	"	"		46190	"	"	
46040	"	"		46191	"	"	
46041	"	"		46192	"	"	
46042	"	"		46193	"	"	
46043	"	"		46194	"	"	
46044	"	"		46195	"	"	
46045	"	"		46196	"	"	
46046	"	"		46197	"	"	
46047	"	"		46198	"	"	
46048	"	"		46199	"	"	
46049	"	"		46200	"	"	
46050	"	"		46201	"	"	
46051	"	"		46202	"	"	
46052	"	"		46203	"	"	
46053	"	"		46204	"	"	
46054	"	"		46205	"	"	
46055	"	"		46206	"	"	
46056	"	"		46207	"	"	
46057	"	"		46208	"	"	
46058	"	"		46209	"	"	
46059	"	"		46210	"	"	
46060	"	"		46211	"	"	
46061	"	"		46212	"	"	
46062	"	"		46213	"	"	

Vogn nr.	Fabr.	Byggear	Merknad	Vogn nr.	Fabr.	Byggear	Merknad
46214	Hök/ Edf	63					
46215	"	"					
46216	"	"					
46217	"	"					
46218	"	"					
46219	"	"					
46220	"	"					
46221	"	"	1)				
46222	"	"	1)				
46223	"	"					
46224	"	"					
46225	"	"					
46226	"	"					
46227	"	"					
46228	"	"					
46229	"	"					
46230	"	"					
46231	"	"					
46232	"	"					
46233	"	"					
46234	"	"					

1) Isolert. Vognvekt: 15,0 t. Bæreevne A: 17,0 t, B: 21,0 t, C: 25,0 t.
Som S-vogn A: 17,0 t, BC: 21,0 t.

Gtk 5
TYPE 1

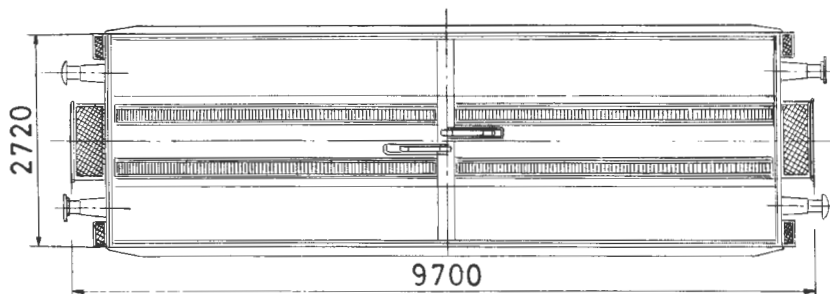
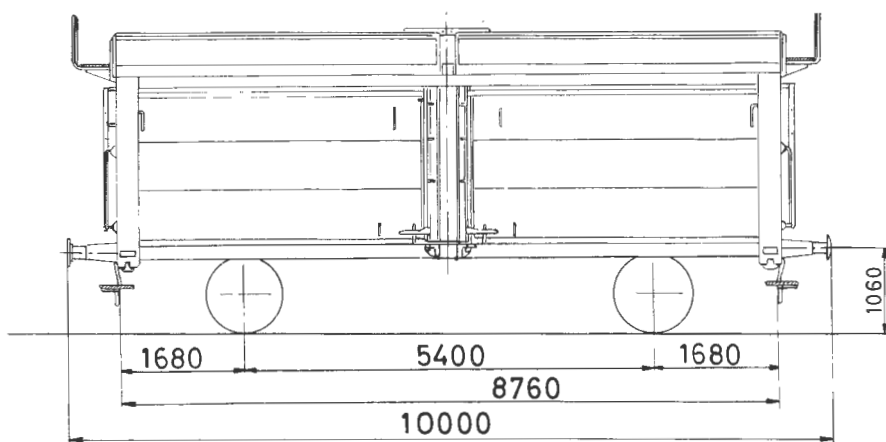

Bæreevne:

	A	B	C
	18,5 t	22,5 t	26,5 t
S	18,5 t	22,5 t	

Omtrentlig vognvekt 13,5 t

Gulvflate 23,8 m²

Rominnhold 57,0 m³

Hovedtegning 124 24

LUKKET GODSVOGN MED SKYVBARE VEGGER OG TAK

Vogn nr.	Fabr.	Byggeår	Merknad	Vogn nr.	Fabr.	Byggeår	Merknad
49500	RSE	62		49514	RSE	62	
49501	"	"		49515	"	"	
49502	"	"		49516	"	"	
49503	"	"		49517	"	"	
49504	"	"		49518	"	"	
49505	"	"		49519	"	"	
49506	"	"					
49507	"	"					
49508	"	"					
49509	"	"					
49510	"	"					
49511	"	"					
49512	"	"					
49513	"	"					

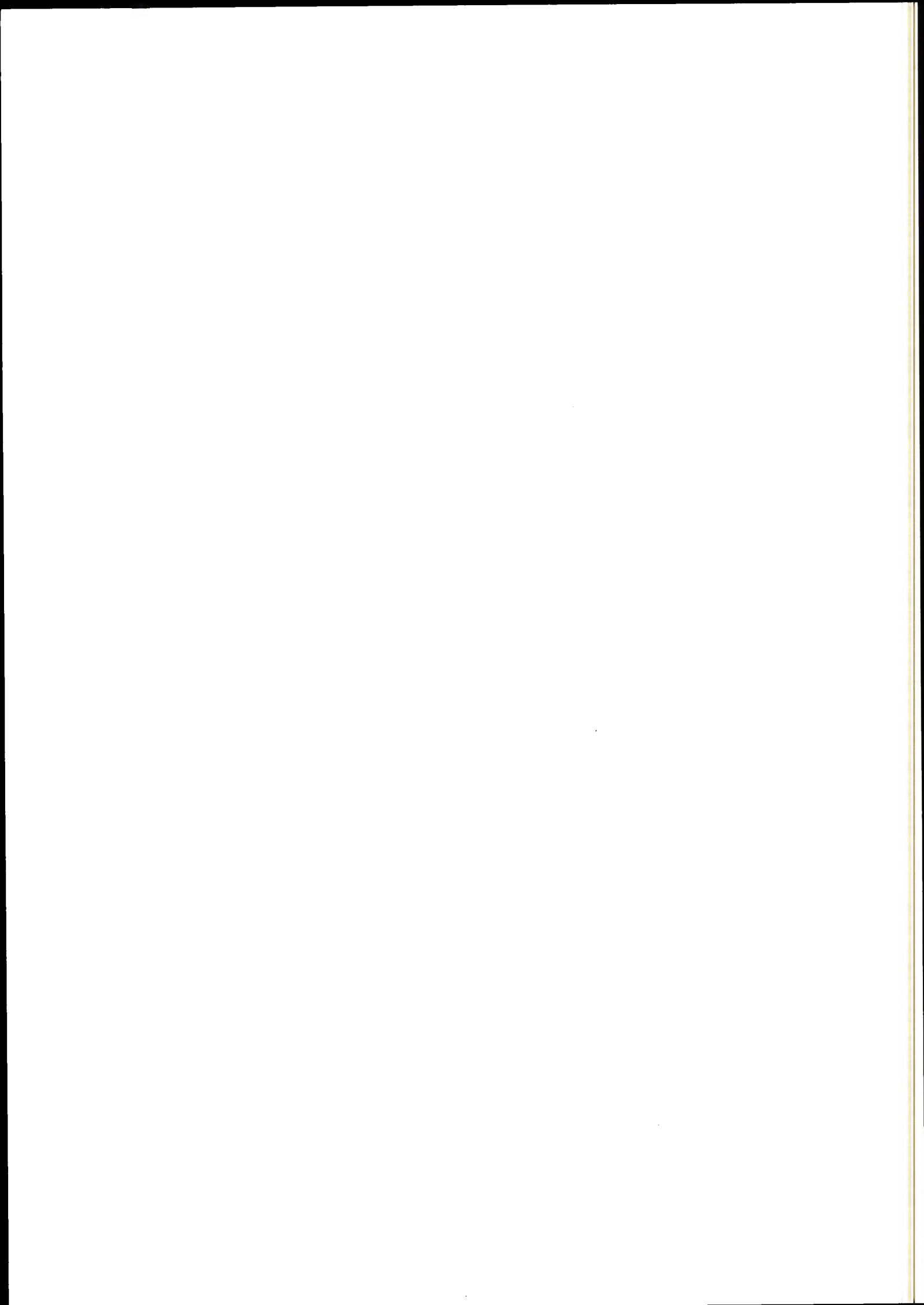

Gt15

TYPE 1

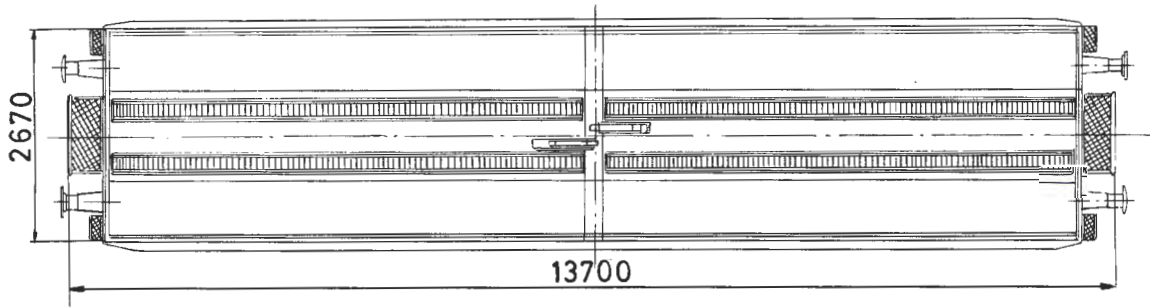
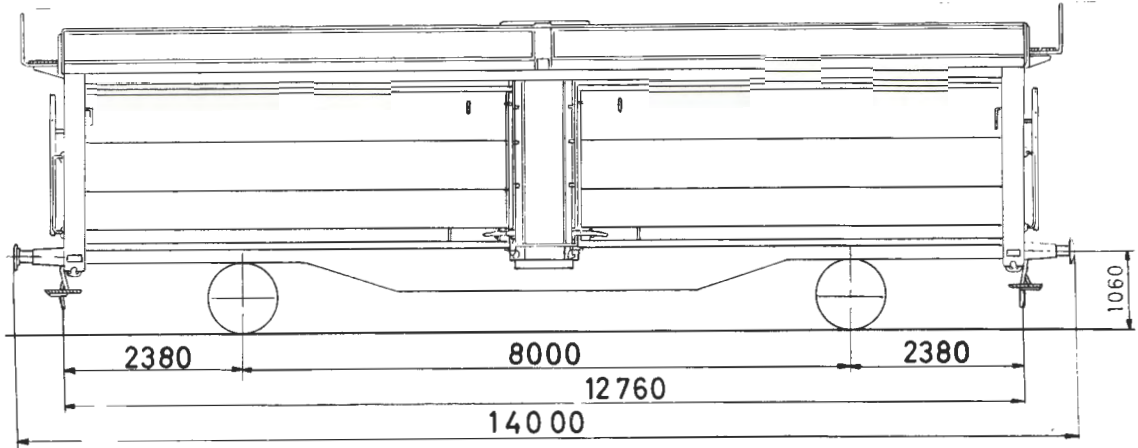

Bæreevne

	A	B	C
	17,5t	21,5t	25,5t
S	17,5t	21,5t	

Omtrentlig vognvekt 14,5 t

Gulvflate 33,0 m²

Rominhold 86,0 m³

Hovedtegning 11853

LUKKET GODSVOGN MED SKYVBARE VEGGER OG TAK

Vogn nr.	Fabr.	Byggeår	Merknad	Vogn nr.	Fabr.	Byggeår	Merknad
49000	RSE	61					
49001	"	"					
49002	"	"					
49003	"	"					
49004	"	"					
49005	"	"					
49006	"	"					
49007	"	"					
49008	"	"					
49009	"	"					

Gv2
TYPE 1

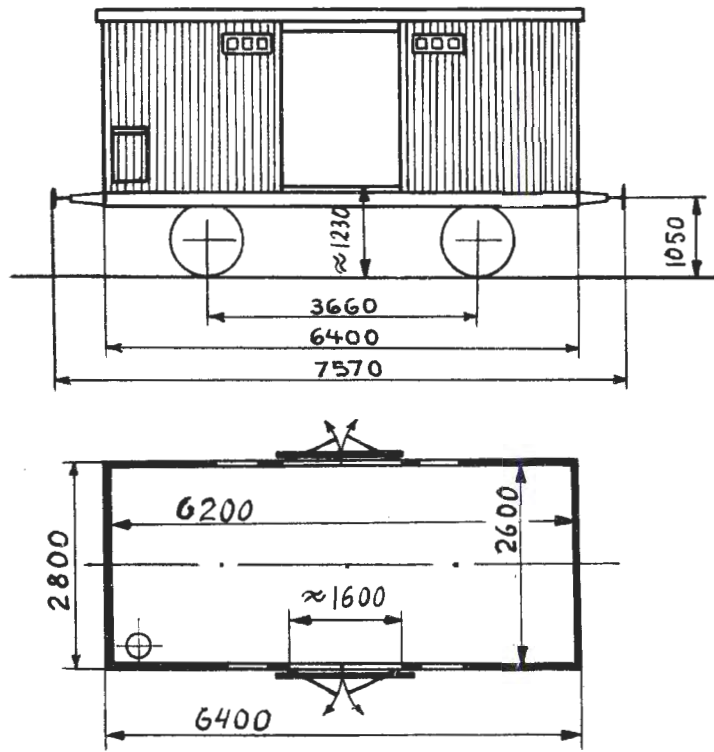

Omtrentlig vognvekt 8,0-8,5 t
 " bæreevne 9,5 t
 Gulvflate 16,1 m²
 Rominnhold 34,0 m³
 Hovedtegning 376

LUKKET GODSVOGN (VARMEVOGN)

Vogn nr.	Fabr.	Byggeår	Merknad	Vogn nr.	Fabr.	Byggeår	Merknad
12166	Str	10	1)				
14184	Skb	"	1)				

1) Forandret etter tegning 4365.

Trykk nr. 752 1.1.64

H
TYPE 1

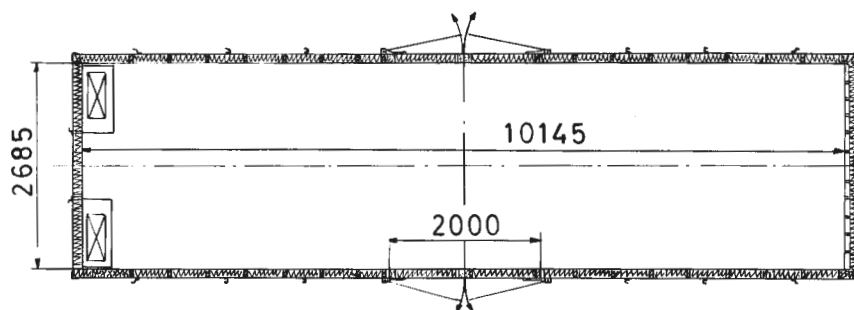
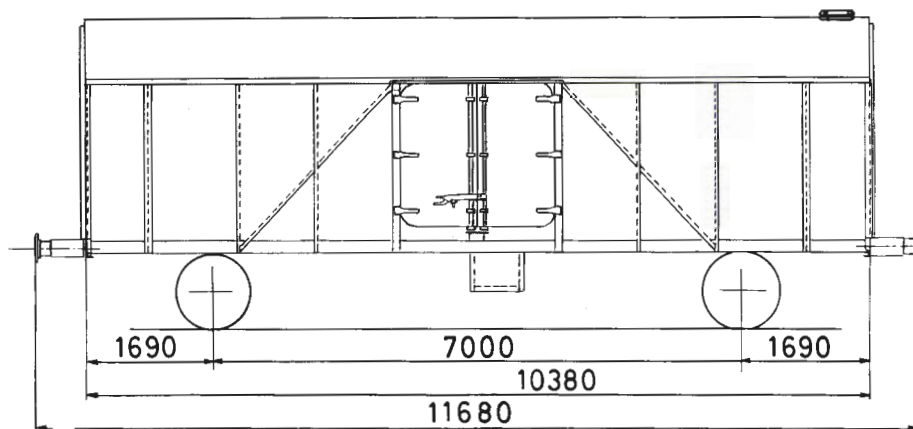

Bæreevne

	A	B	C
	16,5t	16,5t	
S	10,0t		

Omtrentlig vognvekt 13,5 t

Gulvflate 26,1 m²

Rominhold 58,0 m³

Hovedtegning 11460

KJÖLEVOGN

Vogn nr.	Fabr.	Byggeår	Merknad	Vogn nr.	Fabr.	Byggeår	Merknad
70500	1)	44					

1) Omb.i Oslo i 1962.

H3

TYPE 1

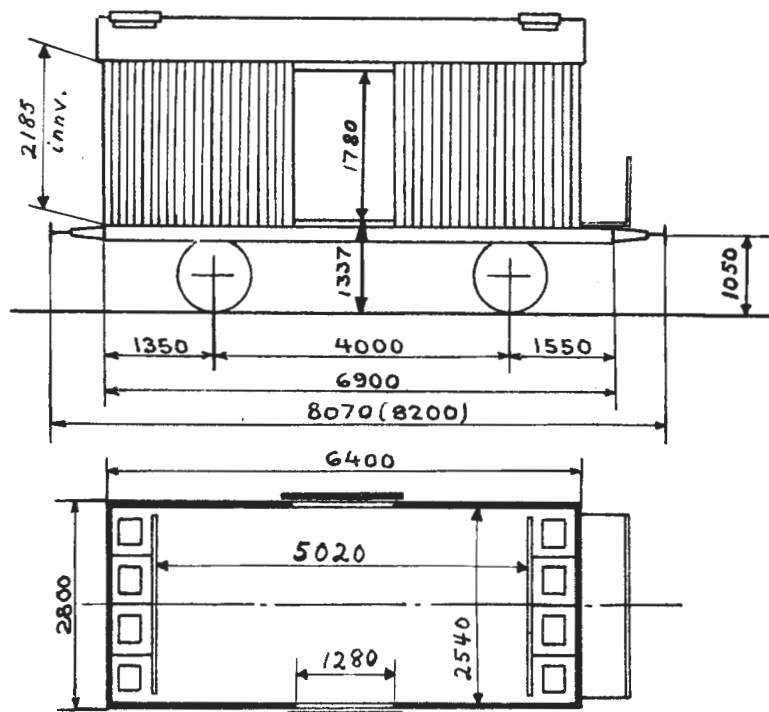

Omtrentlig vognvekt 10,5-14,0 t 1)
 " bæreevne 8,0-13,5 t₂ 2)
 Gulvflate 12,5-15,5 m₃
 Rominnhold 23,0-33,0 m³
 Hovedtegning 1504 + skisse nr. 233
 eller 1218 + skisse nr. 233

KJÖLEVOGN

Vogn nr.	Fabr.	Byggeår	Merknad	Vogn nr.	Fabr.	Byggeår	Merknad	
13100	Str	14	H-tegn. 1504 + skisse nr. 233	13113	Str	11	H-tegn. 1218 + skisse nr. 233	
13101	"	"		13114	"	"		
13102	"	"		13115	"	"		
13103	"	"		13116	"	"		
13105	Edf	"		13117	"	"		3) 4)
13106	"	"		13119	"	"		
13107	"	"		13120	"	"		
13108	"	"		13121	"	"		
13109	"	"		13123	"	"		
13110	"	"		13125	"	"		
13111	"	"		13126	"	"		
13112	"	"		13127	"	"		
				13128	"	"	3)	
				13129	"	"		

1) Med tomme isbeholdere. 2) Inklusive is. 3) Kullsyreis. 4) Ny vognkasse. 5) Har ikke isbeholdere.

Trykk nr. 752 1.1.63

Vogn nr.	Fabr.	Byggeår	Merknad	Vogn nr.	Fabr.	Byggeår	Merknad
13130	Str	11		13163	Skb	11	
13131	"	"		13164	"	"	
13132	"	"		13165	"	"	
13133	"	"		13167	"	"	
13134	"	"	3)	13168	"	"	
13135	"	"		13169	"	"	
				13170	"	"	
			H-tegn. 1504 + skisse nr. 233	13171	"	"	3)
13137	HJ	15	5)	13172	"	"	
13138	"	14	5)	13177	"	"	3)
13139	"	"		13178	"	"	
13140	"	"		13179	"	"	
13141	"	15		13180	"	"	5)
13142	"	14					
13143	"	"					H-tegn. 1504 + skisse nr. 233
13144	"	"		13200	Str	20	5)
13145	"	"		13201	"	"	5)
13146	"	"		13202	"	"	5)
				13203	"	"	5)
			H-tegn. 1218 + skisse nr. 233	13205	"	"	5)
13147	Edf	11		13206	"	"	5)
13148	"	"		13207	"	"	5)
13150	"	"		13208	"	"	5)
13151	"	"		13209	"	"	5)
13152	"	"	3)	13210	"	"	5)
13153	"	"		13211	"	"	
13154	"	"		13212	"	14	5)
13155	"	"	3)	13213	"	"	5)
13156	Str	21	3) 4)	13214	"	"	5)
13157	Skb	11		13215	"	"	5)
13158	"	"	3)	13217	"	"	5)
13159	"	"		13218	"	"	5)
13160	"	"		13219	"	"	
13161	"	"		13220	"	"	5)
13162	"	"		13221	"	"	
				13222	"	"	5)

3) Kullsyreis. 4) Ny vognkasse. 5) har ikke isbeholdere.

Vogn nr.	Fabr.	Byggeår	Merknad	Vogn nr.	Fabr.	Byggeår	Merknad
13223	Str	14	5)	13259	HJ	14	
13224	"	"	5)	13260	"	"	5)
13225	"	"	5)	13261	"	"	5)
13226	"	"	5)	13262	"	"	5)
13227	"	"	5)	13264	"	"	5)
13228	"	"	5)	13265	"	"	5)
13229	"	"	5)	13266	"	"	5)
13231	"	"	5)	13268	"	15	5)
13232	"	"	5)	13270	"	"	5)
13233	"	"	5)	13271	"	"	5)
13234	"	"	3) 4) 6)	13272	"	"	5)
13235	"	"	5)	13273	"	"	5)
13236	"	"	5)	13274	"	"	5)
13237	"	"	5)	13275	"	"	5)
13238	Edf	"	5)	13276	"	"	5)
13239	"	"	5)	13277	"	"	5)
13240	"	"		13278	"	"	5)
13241	"	"	5)	13279	"	"	5)
13242	"	"	5)	13280	"	"	5)
13244	"	"	5)	13282	"	"	5)
13246	"	"	5)	13283	"	"	5)
13247	"	"		13284	"	"	5)
13248	"	"	5)	13285	"	"	
			H-tegn. 1218 + skisse nr. 233	13286	"	"	
13250	Str	11	5)	13287	"	"	5)
13251	"	"	5)	13289	Skb	21	5)
13252	"	"	5)	13290	"	"	5)
13253	"	"	5)	13291	"	"	5)
13254	"	"	5)	13292	"	"	5)
13255	"	"	5)	13293	"	"	5)
13257	Skb	"	5)	13294	"	"	5)
			H-tegn. 1504 + skisse nr. 233	13295	"	"	5)
13258	HJ	14	5)	13296	"	"	5)
				13297	"	"	5)
				13298	"	"	5)

3) Kullsyreis. 4) Ny vognkasse. 5) Har ikke isbeholdere. 6) Har ikke beholdere for naturis.

Vogn nr.	Fabr.	Byggear	Merknad	Vogn nr.	Fabr.	Byggear	Merknad
13299	Skb	21	5)	13337	Str	19	5)
13301	"	"	5)	13338	"	"	5)
13302	"	"	5)	13339	"	"	5)
13303	"	"	5)	13340	"	"	5)
13304	Str	20	5)	13341	"	"	5)
13305	"	"	5)	13342	"	"	5)
13306	"	"	5)	13343	"	"	5)
13307	"	"	5)	13344	"	21	
13308	"	"	5)	13345	"	19	5)
13309	"	"	5)	13347	"	21	5)
13310	"	"	5)	13348	"	"	5)
13311	"	"	5)	13350	"	"	5)
13312	"	"	5)	13351	"	"	5)
13313	"	19	5)	13352	"	"	5)
13314	"	"	5)	13353	"	"	5)
13315	"	"	5)	13354	"	"	5)
13316	"	"	5)	13355	"	"	5)
13317	"	"	5)	13356	"	"	5)
13320	"	"	5)	13357	"	"	5)
13321	"	"	5)	13358	"	"	5)
13322	"	"	5)	13359	"	"	5)
13323	HJ	14	5)	13360	"	"	5)
13324	"	"	5)	13361	"	"	5)
13325	"	"	5)	13362	"	"	5)
13326	"	"	5)	13363	"	"	
13328	"	"	5)	13364	"	"	5)
13331	"	"	5)	13365	"	"	5)
13332	"	"	5)	13366	"	"	5)
13333	Edf	11	H-tegn. 1218 + skisse nr. 233 3) 6)	13367	Skb	11	H-tegn. 1218 + skisse nr. 233 5)
13334	"	"	3) 6)	13368	"	"	3) 6)
13335	Str	19	H-tegn. 1504 + skisse nr. 233 5)	13369	Str	19	H-tegn. 1504 + skisse nr. 233 5)
13336	"	"	5)	13370	"	"	5)

3) Kullsyreis. 5) Har ikke isbeholdere. 6) Har ikke beholdere for naturis.

Vogn nr.	Fabr.	Byggeår	Merknad	Vogn nr.	Fabr.	Byggeår	Merknad
13372	Str	19	5)				
13373	Edf	11	H-tegn. 1218 + skisse nr. 233 5)				
13374	"	"	5)				
13375	Str	19	H-tegn. 1504 + skisse nr. 233 5)				
13376	"	"					
13377	"	"	5)				
13378	"	"	5)				
13379	"	20	5)				
13381	"	21	5)				
13382	"	"	5)				
13383	"	"	5)				
13384	Skb	"	5) 7)				
13385	"	"	5)				
13386	"	"	5)				
13387	"	"					
13388	"	"	5)				
13389	"	"	5)				
13390	"	"	5)				
13393	"	"	5)				
13394	"	"	5)				
13395	"	"	5)				
13396	"	22	5)				
13397	"	"	5)				
13398	"	"	5)				
13399	"	"	5)				
13401	Str	20	5)				
13402	"	"	5)				
13403	HJ	15	5)				
13404	"	"	5)				
13405	Str	21	5)				
13406	"	20	5)				

5) Har ikke isbeholdere. 7) Innredet for banantransport.

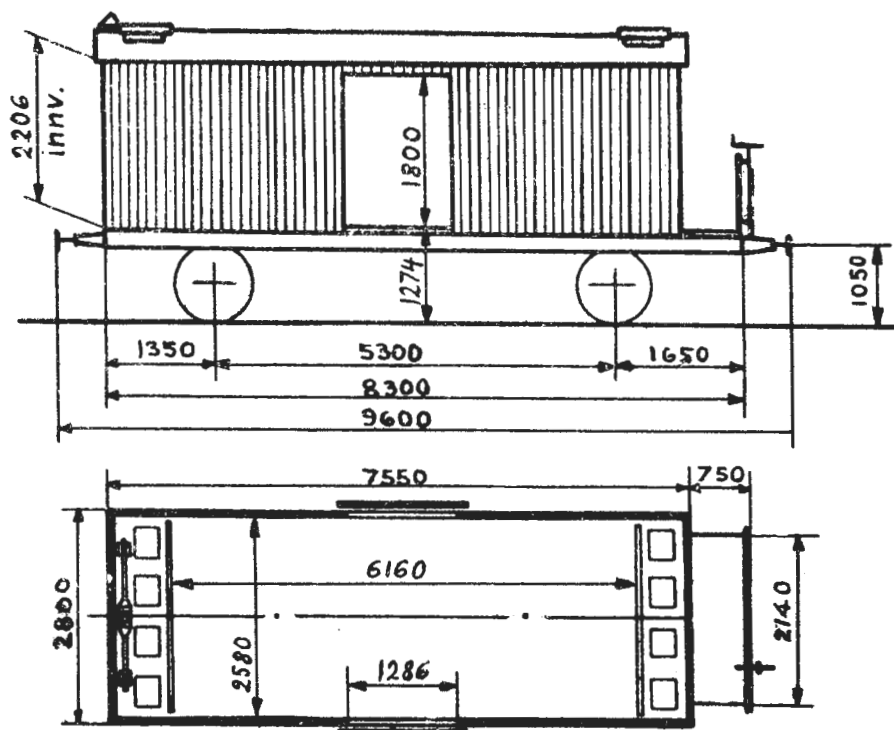

Vogner i serien 70000-70029 har som S-vogn 12,0 t bæreevne.
Vogner i serien 70030-70074 har som S-vogn 10,0 t bæreevne.

Omtrentlig vognvekt 14,5-17,0 t 1)
" bæreevne 13,5-15,5 t 2)
Gulvflate 15,8 m²
Rominnhold 32,4 m³
Hovedtegning 3160 + skisse nr. 1085

KJÖLEVOGN

Vogn nr.	Fabr.	Byggeår	Merknad	Vogn nr.	Fabr.	Byggeår	Merknad
70001	Skb	30	3)	70017	Skb	31	
70002	"	"		70019	Edf	30	
70003	"	"		70020	"	"	
70004	"	"		70021	"	"	
70005	"	"		70022	"	"	
70006	"	"		70023	"	"	
70007	"	"		70024	Skb	31	
70008	"	"					
70009	"	"					
70010	"	"					
70011	"	31					
70012	"	"					
70013	"	"	3)				
70014	"	"					
70016	"	"					

1) Med tomme isbeholdere. 2) Inklusive is. 3) Innredet som forsøksvogn for fiskeriforsøksstasjoner. Kullsyreis. Trykk nr. 752 1.1.63

H 4

TYPE 2

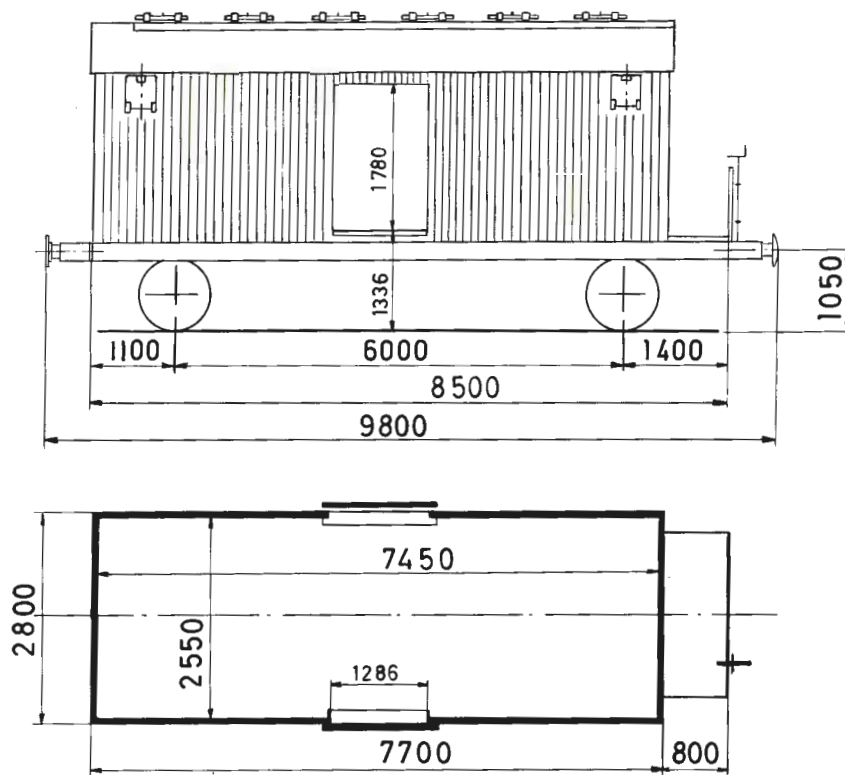

Vogner i serien 70000-70029 har
som S-vogn 12,0t bæreevne.

Vogner i serien 70030-70074 har
som S-vogn 10,0t bæreevne.

Omtrentlig vognvekt 13,0-14,0t ¹⁾

" bæreevne 16,0-17,0t ²⁾

Gulvflate 18,7m²

Rominnhold 35,6m³

Hovedtegning 5130

+ skisse nr. 1085

KJÖLEVOGN

Vogn nr.	Fabr.	Byggeår	Merknad	Vogn nr.	Fabr.	Byggeår	Merknad
70026	Skb	47	3)				
70029	"	"	3)				
70034	"	"	3)				
70050	Str	45	3)				
70055	"	"	3)				
70056	"	"	3)				
70060	"	46	3)				
70066	"	"	3)				
70068	"	"	3)				
70071	"	"	3)				
70072	"	"	3)				
70073	"	"	3)				
70074	"	"	3)				

1) Med tomme isbøholdere. 2) Inklusive is. 3) Benyttes for transport av matvarer, unntatt fisk.

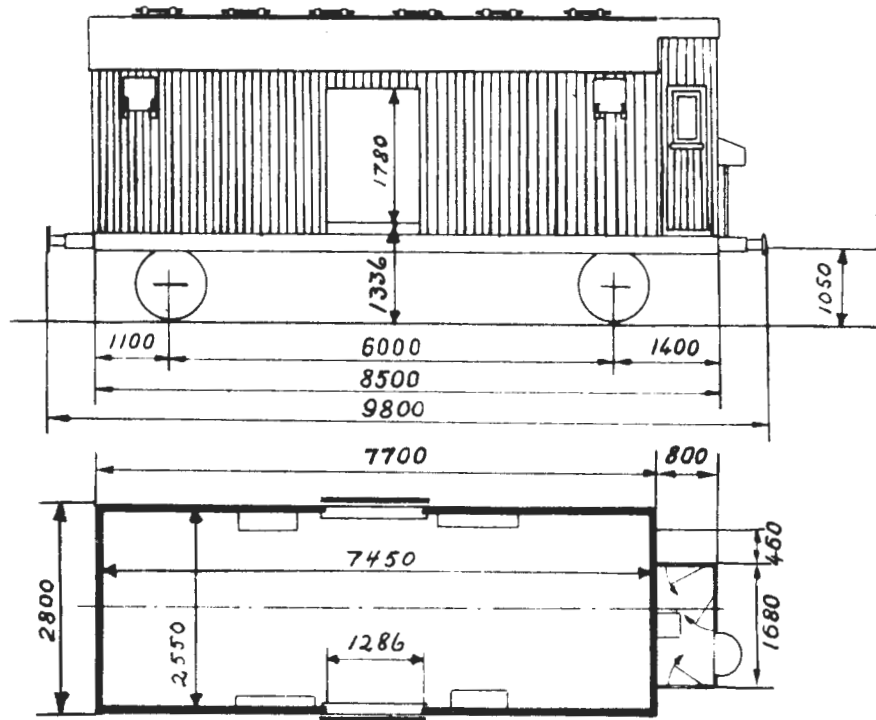

Vogner i serien 70000-70029 har som S-vogn 12,0 t bæreevne.
Vogner i serien 70030-70074 har som S-vogn 10,0 t bæreevne.

Omtrentlig vognvekt 13,5-14,0 t 1)
" bæreevne 16,0-16,5 t 2)
Gulvflate 18,7 m²
Rominnhold 35,6 m³
Hovedtegning 5130

KJÖLEVOGN

Vogn nr.	Fabr.	Byggeår	Merknad	Vogn nr.	Fabr.	Byggeår	Merknad
70025	Skb	47	3)	70048	Skb	48	
70027	"	"	3)	70049	"	"	3)
70028	"	"		70051	Str	45	3)
70030	"	"		70053	"	"	3)
70031	"	"	3)	70054	"	"	3)
70032	"	"	3)	70057	"	46	3)
70036	"	"	3)	70059	"	"	3)
70039	"	48	3)	70061	"	"	3)
70040	"	"	3)	70062	"	"	3)
70041	"	"		70063	"	"	3)
70043	"	"	3)	70064	"	"	3)
70044	"	"	3)	70065	"	"	3)
70045	"	"	3)	70069	"	"	3)
70046	"	"		70070	"	"	3)
70047	"	"	3)				

1) Med tomme isbeholdere. 2) Inklusive is. 3) Benyttes for transport av matvarer, unntatt fisk.

Hv3

TYPE 1

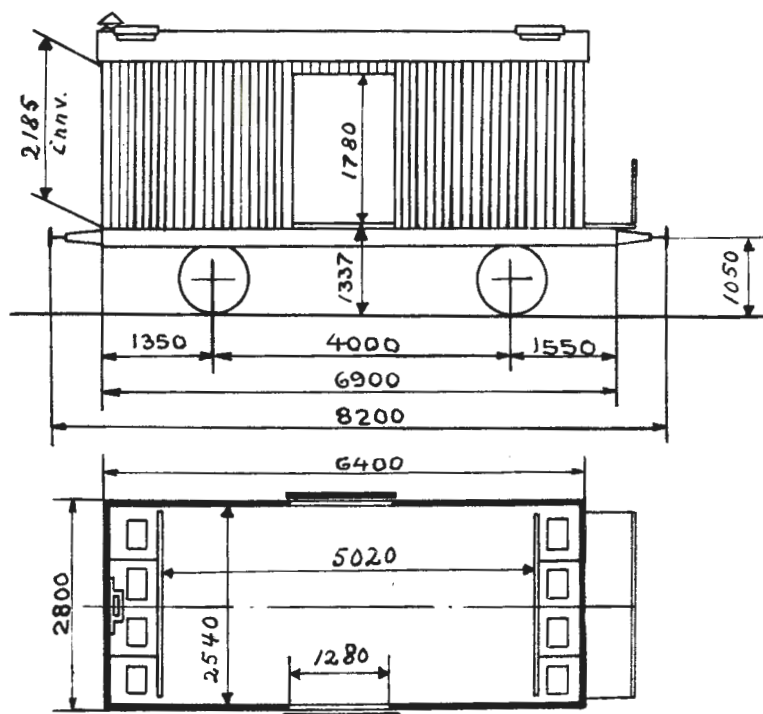

Omtrentlig vognvekt 12,0-14,0 t 1)
 " bæreevne 9,5-12,0 t 2)
 Gulvflate 12,8-13,0 m²
 Rominnhold 26,2-26,6 m³
 Hovedtegning 1504 + skisse nr. 233

KJÖLE- OG VARMEVOGN

Vogn nr.	Fabr.	Byggeår	Merknad	Vogn nr.	Fabr.	Byggeår	Merknad
5580	HJ	14					
13216	Str	" 3)					
13263	HJ	"					
13281	"	15					
13288	Edf	14					
✓ 13300	Skb	21					
13319	Str	19					
13330	HJ	14					
13380	Str	21					

1) Med tomme isbeholdere. 2) Inklusive is. 3) Har ikke isbeholdere.

Hv4

TYPE 1

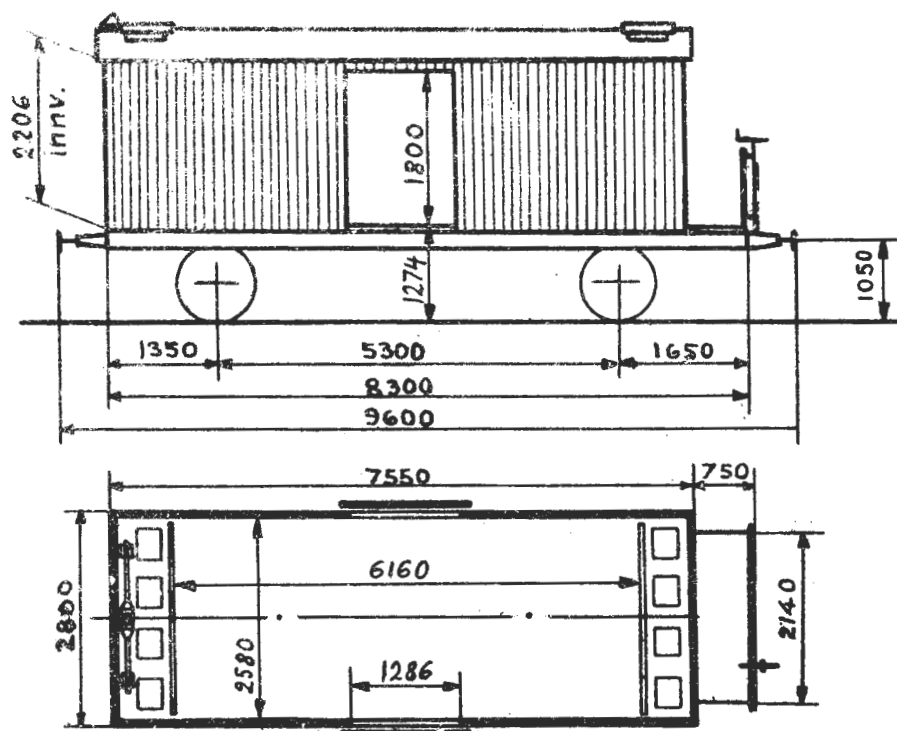

Vogner i serien 70000-70029 har som S-vogn 12,0 t bæreevne.
 Vogner i serien 70030-70074 har som S-vogn 10,0 t bæreevne.

Omtrentlig vognvekt 14,0-16,0 t 1)
 " bæreevne 14,0-15,5 t 2)
 Gulvflate 15,8 m²
 Rominnhold 32,4 m³
 Hovedtegning 3160 + skisse nr. 1085

KJÖLE- OG VARMEVOGN

Vogn nr.	Fabr.	Byggeår	Merknad	Vogn nr.	Fabr.	Byggeår	Merknad
70000	Skb	30					
70015	"	31					

1) Med tomme isbeholdere. 2) Inklusive is.

Trykk nr. 752 1.1.62

Hv4

TYPE 2

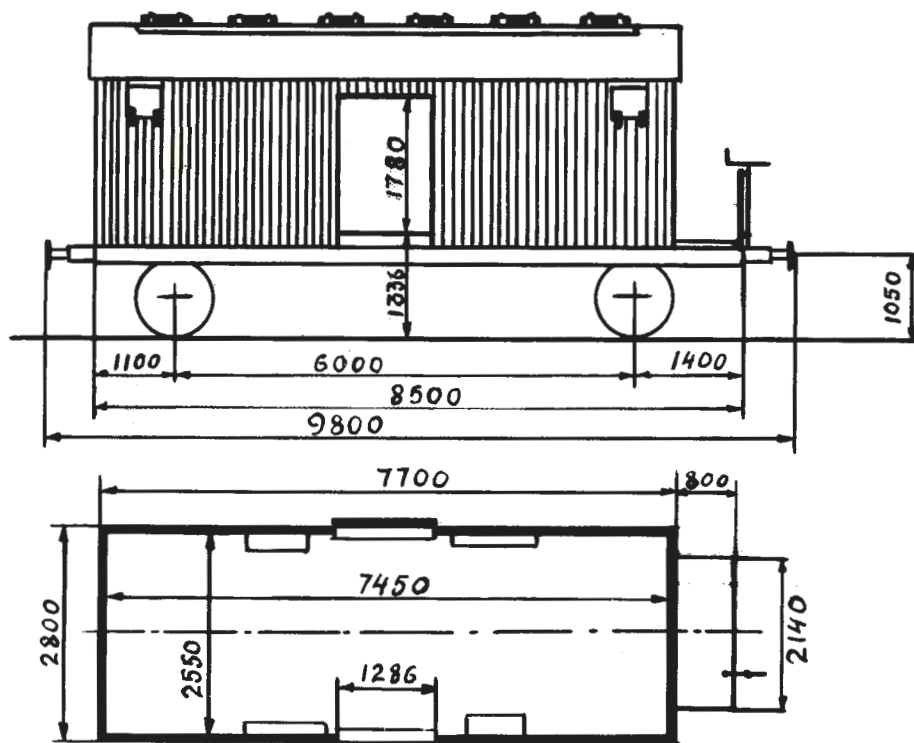

Vogner i serien 70000-70029 har som S-vogn 12,0 t bæreevne.
 Vogner i serien 70030-70074 har som S-vogn 10,0 t bæreevne.

Omtrentlig vognvekt	14,0 t 1)
" bæreevne	16,5 t 2)
Gulvflate	18,7 m ²
Rominnhold	35,6 m ³
Hovedtegning	5130 + skisse nr. 1085

KJÖLE- OG VARMEVOGN

Vogn nr.	Fabr.	Byggeår	Merknad	Vogn nr.	Fabr.	Byggeår	Merknad
70067	Str	45	3)				

1) Med tomme isbeholdere. 2) Inklusive is. 3) Benyttes for transport av matvarer, unntatt fisk.

Trykk nr. 752 1.1.64

Hvf 4

TYPE 2

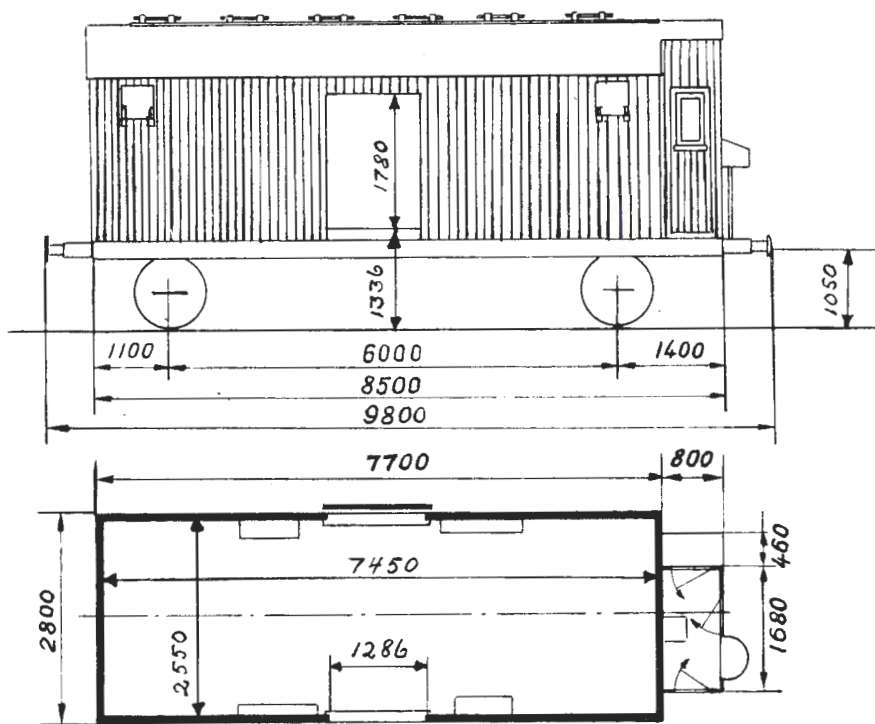

Vogner i serien 70000-70029 har som S-vogn 12,0 t bæreevne.
Vogner i serien 70030-70074 har som S-vogn 10,0 t bæreevne.

Omtrentlig vognvekt 14,0-14,5 t 1)
" bæreevne 16,0 t 2)
Gulvflate 18,7 m²
Rominnhold 35,6 m³
Hovedtegning 5130

KJÖLE- OG VARMEVOGN

Vogn nr.	Fabr.	Byggeår	Merknad	Vogn nr.	Fabr.	Byggeår	Merknad
70033	Skb	47	3)				
70035	"	"					
70037	"	"					
70038	"	48					
70042	"	"					
70047	"	"	3)				
70052	Str	45	3)				
70058	"	46	3)				

1) Med tomme isbeholdere. 2) Inklusive is. 3) Benyttes for transport av matvarer, unntatt fisk.

Trykk nr. 752 1.1.64

K1

TYPE 1

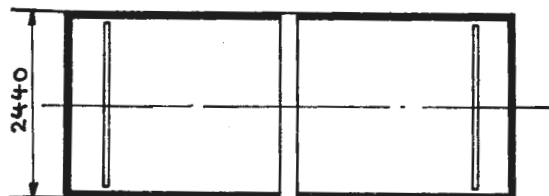
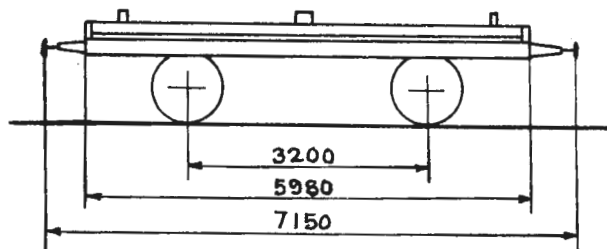

Omtrentlig vognvekt	5,0 t
" last	11,5 t
Gulvflate	13,3 m ²
Rominnhold	1,6 m ³
Hovedtegning	Ukjent

TÖMMERVOGN

Vogn nr.	Fabr.	Byggeår	Merknad	Vogn nr.	Fabr.	Byggeår	Merknad
2153	Str	75					
2158	"	"					
2160	"	"					

Vognene er ombygd i Oslo distrikt 1903-06.

K1

TYPE 2

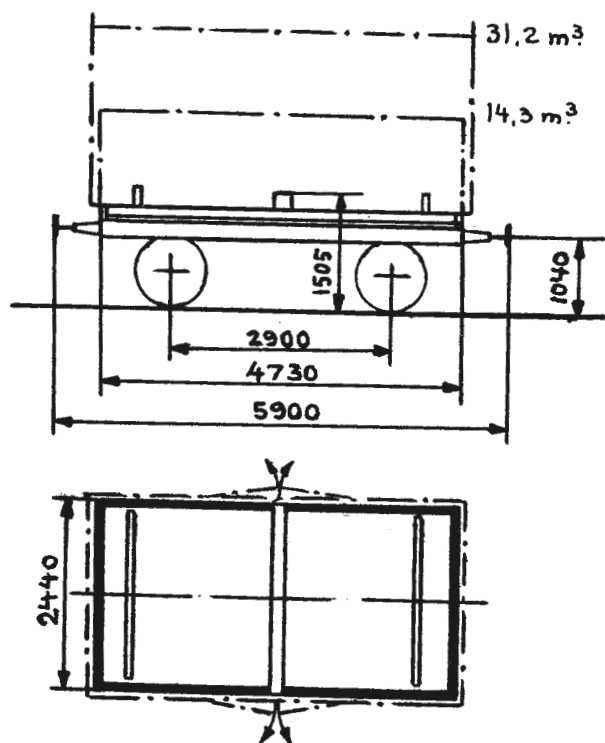

Omtrentlig vognvekt 5,0- 6,0 t
 " last 11,0-11,5 t₂
 Gulvflate 10,6 m²
 Rominnhold -
 Hovedtegning 138

TÖMMERVOGN

Vogn nr.	Fabr.	Byggeår	Merknad	Vogn nr.	Fabr.	Byggeår	Merknad
1384	Str	97	1)				
2177	Oslo	99	1)				
2181	Skb	91	2)				
2201	Oslo	04	2)				
2240	"	01	1)				
2260	"	04	2)				

1) Rominnhold 31,2 m³. 2) Rominnhold 1,3 m³.

K1

TYPE 3

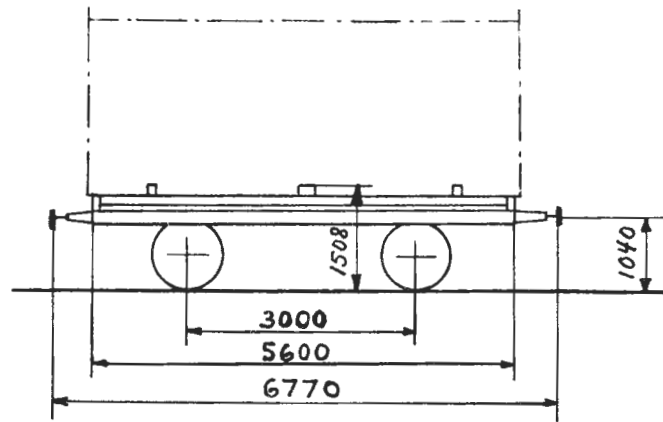

Omtrentlig vognvekt 5,5 t
" last 10,5-11,0 t
Gulvflate 15,0 m²
Rominnhold 35,5 m³ 1)
Hovedtegning B 119

TÖMMERVOGN

Vogn nr.	Fabr.	Byggeår	Merknad	Vogn nr.	Fabr.	Byggeår	Merknad
1313	Str	03					

1) Med kasse for treavfall.

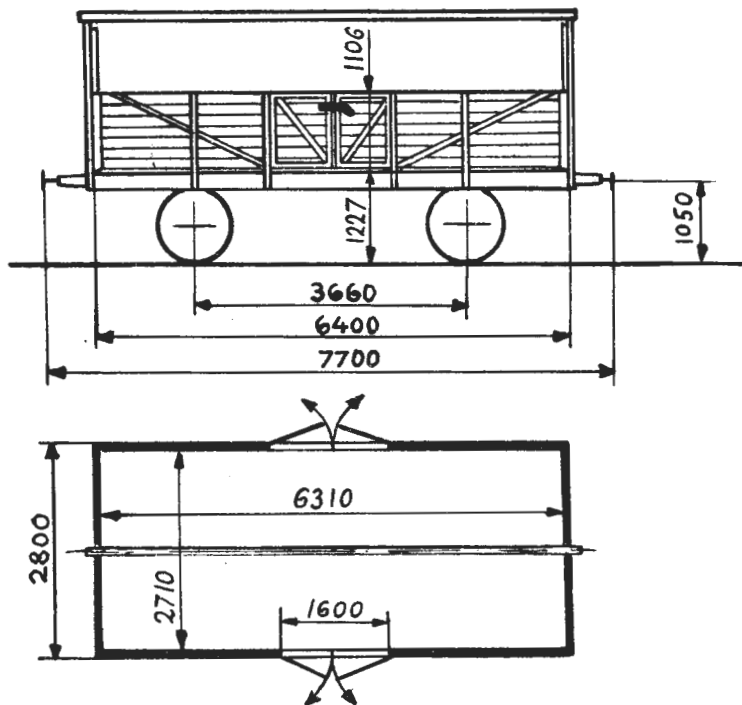

Omtrentlig vognvekt 6,5 t
 " last 11,0 t₂
 Gulvflate 17,0 m²
 Rominnhold 18,7 m³
 Hovedtegning Omb. etter hovedtegn. 1519 med tilleggstejn. som angitt nedenfor.

KASSEVOGN

Vogn nr.	Fabr.	Byggeår	Merknad	Vogn nr.	Fabr.	Byggeår	Merknad
2019	Skb	99	1)				

1) Tilleggstejnning D 10815.

L3

TYPE 1

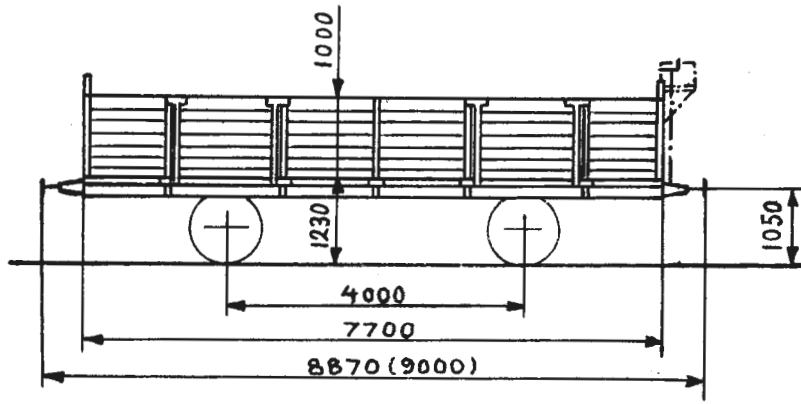

Alle lemmer
kan tas av.

Omtrentlig vognvekt 7,5- 8,0 t
 " bæreevne 15,0-16,0 t₂
 Gulvflate 21,4 m²
 Rominnhold 21,4 m³
 Hovedtegning 578

KASSEVOGN

Vogn nr.	Fabr.	Byggeår	Merknad	Vogn nr.	Fabr.	Byggeår	Merknad
13033	Edf	05					
13038	"	"					

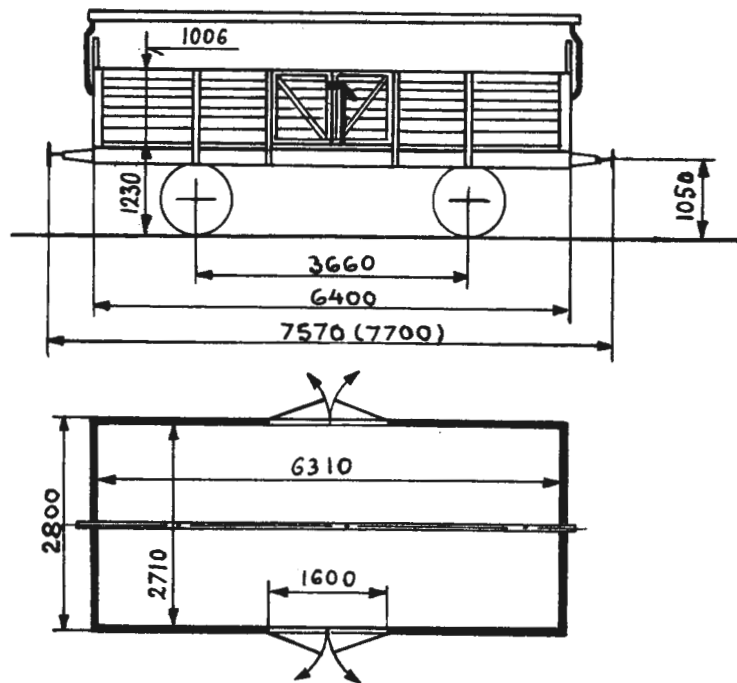

Bæreevne

A	B	C
16,5t	16,5t	

Omtrentlig vognvekt 6,5-8,0 t
 Gulvflate 17,0 m²
 Rominnhold 17,0-18,7 m³
 Hovedtegning 1070, 1519, 1708
 eller 5567+1519

KASSEVOGN

Vogn nr.	Fabr.	Byggeår	Merknad	Vogn nr.	Fabr.	Byggeår	Merknad
			H-tegn. 5567+1519	3682	Str	23	
3123	Edf	08	1)	3684	"	"	
3174	Skb	26	1)	3687	"	"	
3393	"	25	1)	3688	"	"	
			H-tegn. 1519	3689	"	"	
3662	AaB	24		3701	Oslo	"	
3664	"	"		3703	"	22	
3665	"	"		3704	"	23	
3666	"	25		3708	"	24	
3667	"	"		3709	"	"	
3669	"	"		3711	"	"	
3676	Str	23		3712	"	"	
3677	"	"		3713	"	22	
3681	"	"		3716	"	24	
				3717	"	"	

1) Opprinnelig hovedtegn. 376.

Trykk nr. 752 1.1.64

L3
TYPE 2

Vogn nr.	Fabr.	Byggeår	Merke	Vogn nr.	Fabr.	Byggeår	Merke
3719	Oslo	24		5427	AaB	25	
3720	"	22		5429	"	"	
3721	"	24		5431	"	"	
3722	"	22		5432	"	"	
3723	"	24		5433	"	"	
3724	"	"		5434	"	"	
3725	"	"		5435	"	"	
3726	"	"		5436	"	"	
3728	"	28					
3729	"	"		5449	Skb	27	H-tegn. 5567+1519 1)
3730	"	"		5465	"	"	1)
3746	"	13					
3791	Str	23		5622	HJ	13	H-tegn. 1519
3792	"	"		5632	"	"	
3794	"	"		6932	Skb	21	
3795	"	"		6933	"	"	
3797	"	"		6934	"	"	
3798	"	"		6935	"	"	
3799	"	"		6936	"	"	
3800	"	"		6937	"	"	
5134	AaB	16		6938	"	"	
5141	"	"		6942	"	"	
5408	Str	24		6943	"	"	
5409	"	"		6944	"	"	
5410	"	"		6945	"	"	
5411	"	"		6946	"	"	
5412	"	"		6948	"	"	
5413	"	"		6949	"	"	
5414	"	"		6950	"	"	
5417	"	"		6951	"	"	
5418	"	"		8383	Str	23	
5419	"	"		10571	Skb	21	
5420	"	"		10572	"	"	
5422	"	"		10573	"	"	
5424	"	"		10574	"	"	

1) Opprinnelig hovedtegn. 376.

Vogn nr.	Fabr.	Byggear	Merknad	Vogn nr.	Fabr.	Byggear	Merknad
10575	Skb	21		12850	AaB	25	
10576	"	"		12851	"	"	
10577	"	"		12852	"	"	
10578	"	"		12853	"	"	
10580	"	"		12854	"	"	
10581	"	"					
10582	"	"					H-tegn. 5567+1519
10583	"	"		14210	Skb	24	1)
10584	"	"		15323	Str	23	1)
10586	"	"		15398	Edf	28	1)
10587	"	"					
10588	"	"					H-tegn. 1070 2)
10590	"	"		15718	MMV	10	
12806	Str	16		15724	"	"	
12811	"	"		15733	"	"	
12815	"	"		15741	AaB	"	
12816	"	24		15757	"	"	
12818	"	"					H-tegn. 1519
12819	"	"		15807	Skb	21	
12820	"	"		15808	"	"	
12821	"	"		15809	"	"	
12822	"	"		15811	"	"	
12824	"	"		15812	"	"	
12825	"	"		15814	"	"	
12826	"	"		15817	"	"	
12827	"	"		15818	"	"	
12829	"	"		15819	"	"	
12830	"	"		15820	"	"	
12832	"	"		15823	"	"	
12836	"	"		15824	"	"	
12839	"	"		15825	"	"	
12843	AaB	25		15826	"	"	
12845	"	"		15828	"	"	
12847	"	"		15829	"	"	
12848	"	"		15830	"	"	

1) Opprinnelig hovedtegn. 376. 2) Gulvhøyde 1218 mm.

Vogn nr.	Fabr.	Byggeår	Merknad	Vogn nr.	Fabr.	Byggeår	Merknad
15832	Skb	21		15934	Str	23	
15833	"	"		15935	"	"	
15834	"	"		15938	"	"	
15836	"	"		15939	"	24	
15837	"	"		15940	"	"	
15838	"	"		15941	"	"	
15839	"	"		15942	"	"	
15840	"	"		15943	"	"	
15841	"	"		15944	"	"	
15842	"	"		15945	"	"	
15843	"	"		15947	"	"	
15845	"	"		15949	"	"	
15846	"	"		15969	"	"	
15847	"	"		15970	"	"	
15848	"	"		15971	"	"	
15850	"	"		15972	"	"	
15851	"	"		15974	"	"	
15854	"	"		15975	"	"	
15855	"	"		15977	AaB	25	
15856	"	"		15978	"	"	
15857	"	"		15979	"	"	
15858	"	"		15982	"	"	
15859	"	"		15983	"	"	
15860	"	"		15984	"	"	
15864	"	"		15988	"	"	
15865	"	"		15990	"	"	
15868	"	"		16573	Skb	28	
15870	"	"		16574	"	"	
			H-tegn. 1708	16575	"	"	
15918	Edf	22	3)	16576	"	"	
			H-tegn. 1519	16577	"	"	
15931	Str	23		16578	"	"	
15932	"	"		16579	"	"	
15933	"	"		16582	"	"	
				16583	"	"	

3) Forandret etter tegn. 8194.

Vogn nr.	Fabr.	Byggeår	Merknad	Vogn nr.	Fabr.	Byggeår	Merknad
16584	Skb	28					
17039	Str	18					
17170	"	21					
20006	HJ	13					
20026	"	"					
20034	"	"					
20045	"	"					
20168	Edf	22					
20170	Str	22	H-tegn. 5567+1519				
20175	Edf	22	H-tegn. 1519				
20184	Str	"					
20187	Str	22	H-tegn. 5567+1519				
20264	AaB	25	H-tegn. 1519				
20265	"	"					
20266	"	"					
20267	"	"					
20268	"	"					
20269	"	"					
20270	"	"					
20271	"	"					
20272	"	"					
20273	"	"					
20745	HJ	13					
20751	"	"					

L3

TYPE 3

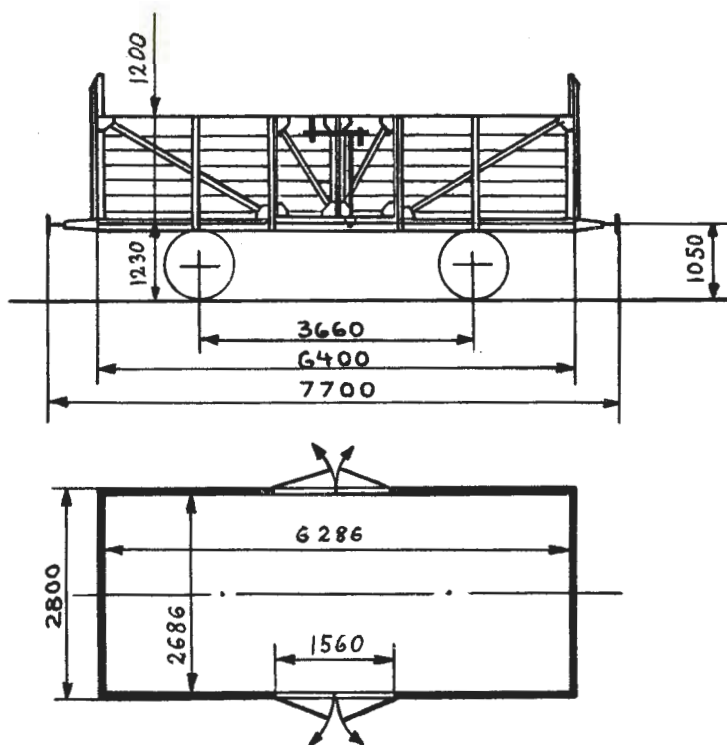

Bæreevne

A	B	C
16,5t	16,5t	

Omtrentlig vognvekt 7,0-7,5 t
 Gulvflate 16,9 m²
 Rominnhold 19,6 m³
 Hovedtegning 2160 1)

KASSEVOGN

Vogn nr.	Fabr.	Byggeår	Merknad	Vogn nr.	Fabr.	Byggeår	Merknad
17537	Skb	22					
17538	"	"					
17539	"	"					

1) Opprinnelig Lg-vogner. Ombygd i 1923-24.

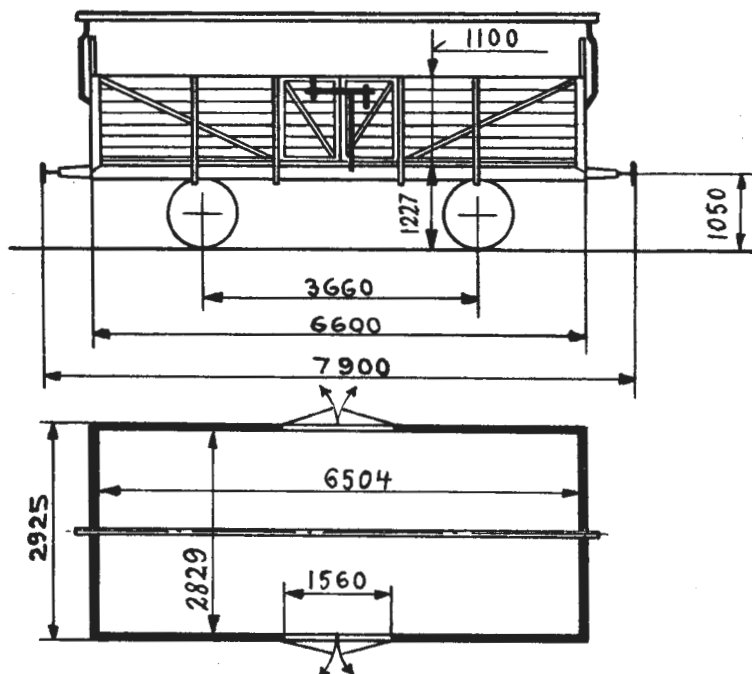

Bæreevne

A	B	C
16,5t	16,5t	

Omtrentlig vognvekt 7,0-8,5 t
 Gulvflate 18,4 m²
 Rominnhold 20,2 m³
 Hovedtegning, oppr. 2175 1)

KASSEVOGN

Vogn nr.	Fabr.	Byggeår	Merknad	Vogn nr.	Fabr.	Byggeår	Merknad
2788	AaB	16		6756	Skb	16	
2789	"	"		6757	"	"	
2791	"	"		6758	"	"	
2792	"	"		6760	"	"	
2793	"	"		6765	"	"	
2795	"	"		6766	"	"	
2796	"	"		6767	"	"	
2797	"	"		6768	"	"	
2798	"	"		6769	"	"	
2799	"	"		15777	"	"	
6743	Skb	"		15779	"	"	
6748	"	"		15781	"	"	
6750	"	"		15783	AaB	"	
6751	"	"		15784	"	"	
6753	"	"		15785	"	"	

1) Omb. etter tegn. D3073.

L3
TYPE 5

Vogn nr.	Fabr.	Byggeår	Merknad	Vogn nr.	Fabr.	Byggeår	Merknad
15789	AaB	16					
15791	"	"					
15793	"	"					
15794	"	"					
15798	"	"					
15800	"	"					
15802	"	"					
15803	"	"					
15804	"	"					
15805	"	"					

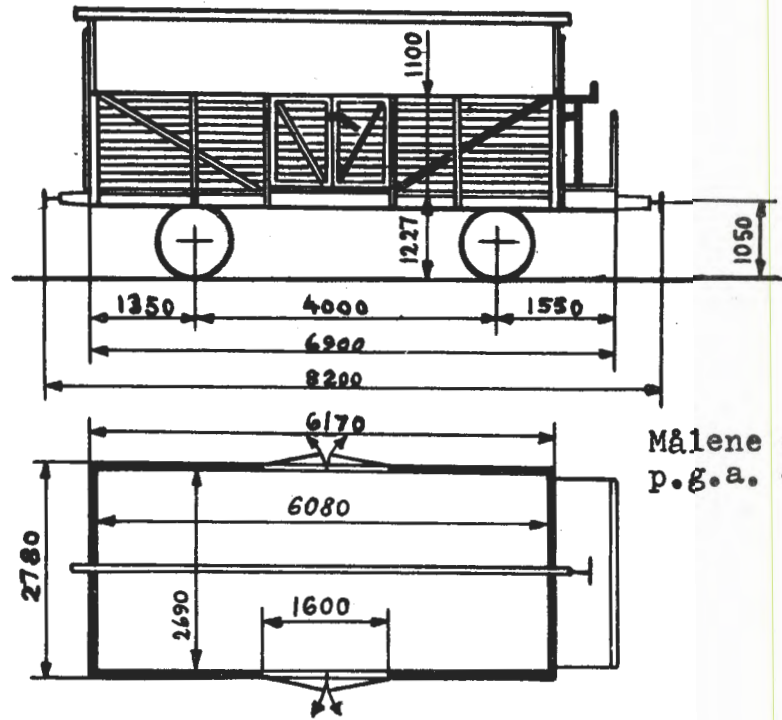

Målene er uvisse
p.g.a. ombygninger

Bæreevne

A	B	C
16,5t	16,5t	

Omtrentlig vognvekt 7,5-8,0 t
 Gulvflate 17,0 m²
 Rominnhold 18,7 m³
 Hovedtegning 5678+5567

KASSEVOGN

Vogn nr.	Fabr.	Byggeår	Merknad	Vogn nr.	Fabr.	Byggeår	Merknad
10042	Edf	11					
10044	"	"					
10054	"	"					
14995	Skb	"					
15455	Edf	"					

L4

TYPE 1

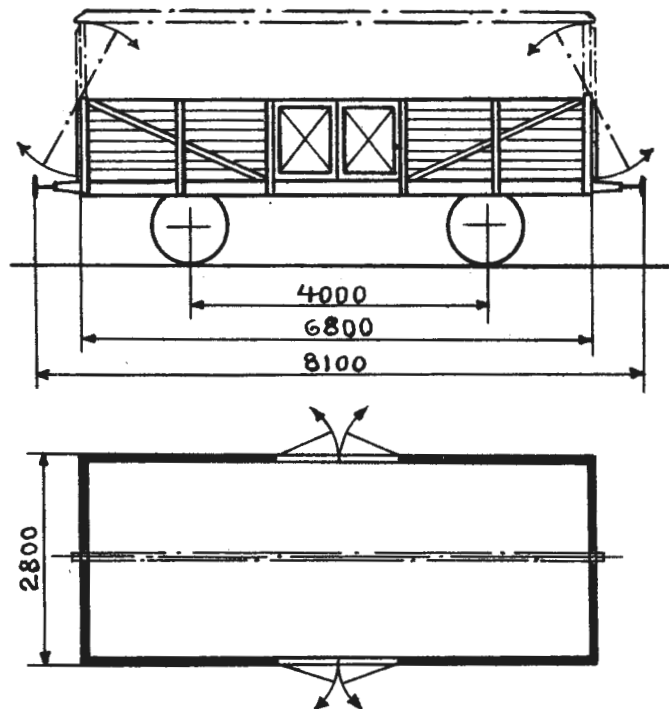

Bæreevne

A	B	C
21,0t		21,0t

Omtrentlig vognvekt 7,0-9,5 t
Gulvflate 18,4 m²
Rominnhold 18,4 m³
Hovedtegning Vognene er innkjøpt
fra Tyskland i 1916

KASSEVOGN

Vogn nr.	Fabr.	Byggeår	Merknad	Vogn nr.	Fabr.	Byggeår	Merknad
10552			1)	11155			1)
10553			1)	11157			1)
10554			1)	11158			1)
10557			1)	11159			1)
10560			1)	11160			1)
10561			1)	11162			1)
10562			1)	11163			1)
10563			1)	11165			1)
10565			1)	11167			1)
10566			1)	11168			1)
10567			1)	11170			1)
10569			1)	11173			1)
10570			1)	11177			1)
11153			1)	11178			1)
11154			1)	11179			1)

1) Presenningsbom og svingbare endevegger.

Trykk nr. 752 1.1.64

Vogn nr.	Fabr.	Byggear	Merknad	Vogn nr.	Fabr.	Byggear	Merknad
11182		1)		32187		1)	
11188		1)		32191			
11368				32193			
11369				32195			
11370				32196			
/ 11372				32197			
11377				32200			
/ 11380				32201			
32125		1)		32203			
32127		1)		32204			
32130		1)		32205			
32132		1)		32207		1)	
32133		1)		32208		1) 4)	
32137				32213			
32140		2)		32214		4)	
32145				32218			
32146		2)		32223			
32148		1)		32224			
32150		1)		32229			
32151		1)		32233			
32152		1)		32234			
32155		1)		32235			
32156		1)		32237			
32157		1)		32240			
32160		1)		32241			
32162		1)		32243			
32163		1)		32244		4)	
32164		1)		32248			
32170		1)		32250			
32172		1)		32268		1)	
32173		2)		32277			
32174		1)		32278			
32175		2)		32279			
32180		1)		32282			
32182		1)		32287			

1) Presenningsbom og svingbare endevegger. 2) Vedgrind. 3) Svingbare endevegger. 4) Söppelkasse.

Vogn nr.	Fabr.	Byggeår	Merknad	Vogn nr.	Fabr.	Byggeår	Merknad
32289				32395			
32291				32396			
32293				32397			
32296				32398			
32297				32401			
32299				32451			
32301				32453			1)
32307				32454			1)
32308				32455			1)
32329				32456			1)
32331				32457			1)
32338				32464			
32340				32469			
32368				32470			
32369				32471			
32370				32473			
32371				32474			1)
32373				32515			
32374				32526			
32376				32529			1)
32377				32544			
32380				32546			
32381				32548			
32382				32549			
32383				32550			
32384				32558			
32385		4)		32567			
32386				32574			
32387				32575			
32388				32583			
32389				32585			
32391				32586			
32392				32594			
32393				32596			
32394				32606			

1) Presenningsbom og svingbare endevegger. 4) Söppelkasse.

Vogn nr.	Fabr.	Byggeår	Merknad	Vogn nr.	Fabr.	Byggeår	Merknad
32609							
32611							
32619							
32630							
32635							
32638							
32645		1)					
32664							
32669							

1) Presenningsbom og svingbare endevegger.

L4
TYPE 2

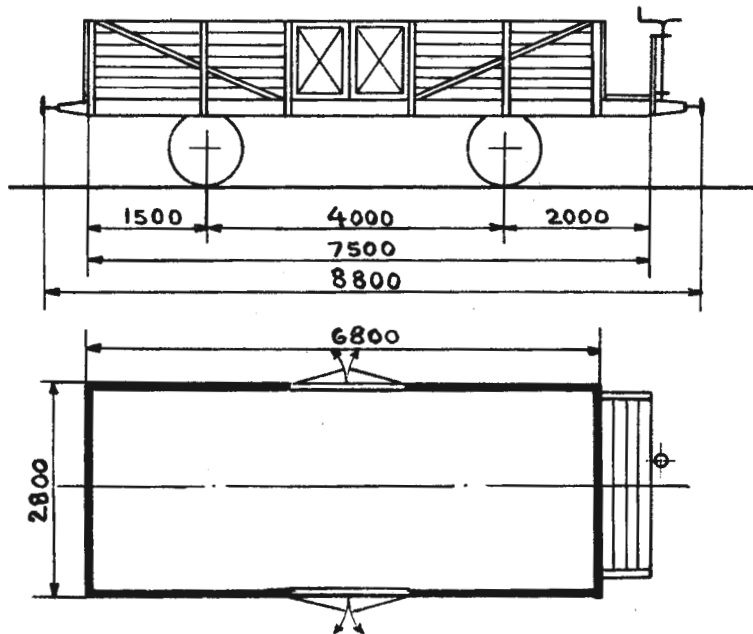

Bæreevne

A	B	C
21,0t	21,0t	

Omtrentlig vognvekt 8,0-10,0 t
 Gulvflate 18,4 m²
 Rominnhold 18,4 m³
 Hovedtegning Vognene er innkjøpt
 fra Tyskland i 1916

KASSEVOGN

Vogn nr.	Fabr.	Byggeår	Merknad	Vogn nr.	Fabr.	Byggeår	Merknad
11191				11385			
11192				11387			1)
11193		1)		11388			
11194				11389			
11195				11390			2)
11196		1)		11392			
11198				11394			
11200				11397			1)
11355				23418			
11361		1)		23420			
11363		1)		23421			
11365				23422			
11382				32123			
11383				32135			1) 2)
11384				32141			

1) Forandret etter skisse nr. 287. 2) Presenningsbom og svingbare endevegger.

Trykk nr. 752 1.1.64

Vogn nr.	Fabr.	Byggeår	Merknad	Vogn nr.	Fabr.	Byggeår	Merknad
32144			2)	32364			1)
32147			2)	32450			2)
32153			1) 2)	32463			
32154			2)	32475			
32178				32478			
32189			2)	32516			
32254			2)	32523			1) 2)
32255			1)	32536			
32256			1)	32537			1) 2)
32257				32540			
32259			2)	32555			1)
32260			2)	32565			
32261				32569			1)
32262				32577			1)
32264				32581			1)
32265			1) 2)	32588			
32266				32598			1)
32267			1)	32608			
32303				32614			1) 2)
32305				32616			
32306				32620			1)
32309				32621			
32318				32625			2)
32320			1)	32639			1)
32324				32648			2)
32328			1)	32654			1)
32332							
32333			1) 2)				
32337							
32342							
32346			1) 2)				
32352			1)				
32357			1)				
32360			1) 2)				
32361			2)				

1) Forandret etter skisse nr. 287. 2) Presenningsbom og svingbare endevegger.

L4

TYPE 3

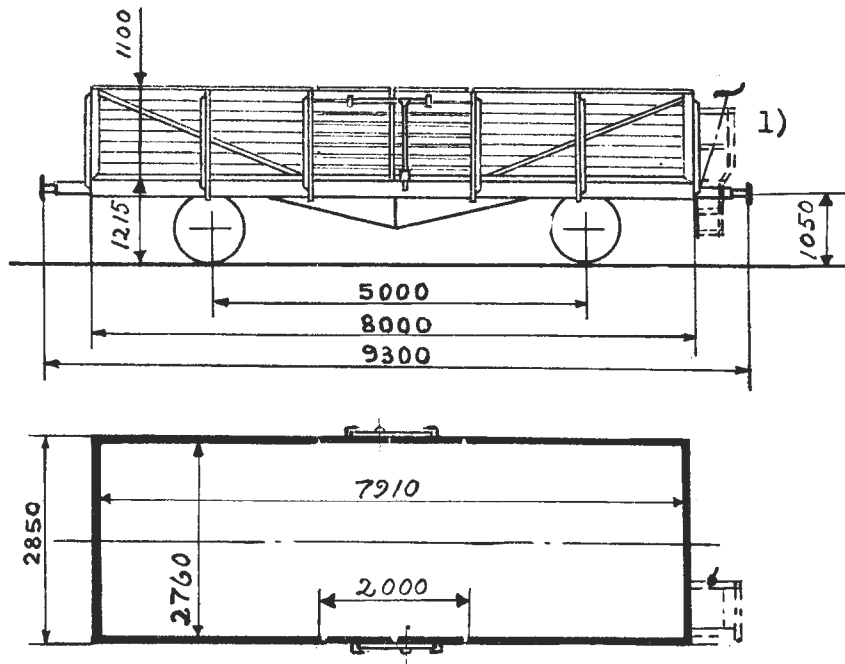

Bæreevne

A	B	C
21,0t	21,0t	

Omtrentlig vognvekt
 Gulvflate
 Rominnhold
 Hovedtegning

8,0-9,0 t₂
 21,8 m²
 24,0 m³
 3989

KASSEVOGN

Vogn nr.	Fabr.	Byggeår	Merknad	Vogn nr.	Fabr.	Byggeår	Merknad
50001	Skb	36		50020	Skb	36	
50002	"	"		50022	"	"	
50003	"	"		50023	"	"	
50004	"	"		50025	Edf	37	
50005	"	"		50026	"	"	
50006	"	"		50027	"	"	
50007	"	"		50028	"	"	
50008	"	"		50029	"	"	
50009	"	"		50032	"	"	
50012	"	"		50035	"	"	
50014	"	"		50039	"	"	
50015	"	"		50041	"	"	
50016	"	"		50042	"	"	
50018	"	"		50043	"	"	
50019	"	"		50044	"	"	

1) Vognene fra nr. 50270 til nr. 50468 har bremserplattform.

Trykk nr. 752 1.1.64

Vogn nr.	Fabr.	Byggeår	Merknad	Vogn nr.	Fabr.	Byggeår	Merknad
50209	Skb	48		50245	Skb	47	
50210	"	"		50246	"	"	
50211	"	"		50247	"	"	
50212	"	"		50248	"	"	
50213	"	"		50249	"	"	
50214	"	"		50250	"	"	
50215	"	"		50251	"	"	
50216	"	"		50252	"	"	
50217	"	"		50253	"	"	
50218	"	"		50254	"	"	
50219	"	"		50255	"	"	
50220	"	47		50256	"	"	
50221	"	"		50257	"	"	
50222	"	"		50258	"	"	
50223	"	"		50259	"	"	
50224	"	"		50260	"	"	
50225	"	"		50261	"	"	
50227	"	"		50262	"	"	
50228	"	"		50263	"	"	
50229	"	"		50264	"	"	
50230	"	"		50265	"	"	
50231	"	"		50266	"	"	
50232	"	"		50267	"	"	
50233	"	"		50268	"	"	
50234	"	"		50269	"	"	
50235	"	"		50270	"	50	
50236	"	"		50271	"	"	
50237	"	"		50272	"	"	
50238	"	"		50274	"	"	
50239	"	"		50275	"	51	
50240	"	"		50276	"	"	
50241	"	"		50277	"	"	
50242	"	"		50279	"	"	
50243	"	"		50280	"	"	
50244	"	"		50281	"	"	

L4
TYPE 3

Vogn nr.	Fabr.	Byggeår	Merknad	Vogn nr.	Fabr.	Byggeår	Merknad
50282	Skb	51		50329	Skb	52	
50283	"	"		50330	"	"	
50285	"	"		50331	"	"	
50286	"	"		50332	"	"	
50287	"	"		50333	"	"	
50288	"	"		50334	"	"	
50289	"	"		50335	"	"	
50290	"	"		50336	"	"	
50291	"	"		50337	"	"	
50292	"	"		50338	"	"	
50293	"	"		50339	"	"	
50294	"	"		50340	"	"	
50295	"	"		50341	"	"	
50296	"	"		50343	"	"	
50297	"	"		50344	"	"	
50299	"	"		50347	"	"	
50301	"	"		50348	"	"	
50304	"	"		50349	"	"	
50305	"	"		50350	"	"	
50306	"	"		50351	"	"	
50310	"	"		50353	"	"	
50313	"	"		50354	"	"	
50314	"	"		50355	"	"	
50315	"	"		50356	"	"	
50316	"	"		50357	"	"	
50317	"	"		50358	"	"	
50318	"	"		50360	"	"	
50320	"	52		50361	"	"	
50321	"	"		50362	"	"	
50322	"	"		50363	"	"	
50323	"	"		50367	"	"	
50324	"	"		50368	"	"	
50326	"	"		50369	"	"	
50327	"	"		50370	"	"	
50328	"	"		50371	"	"	

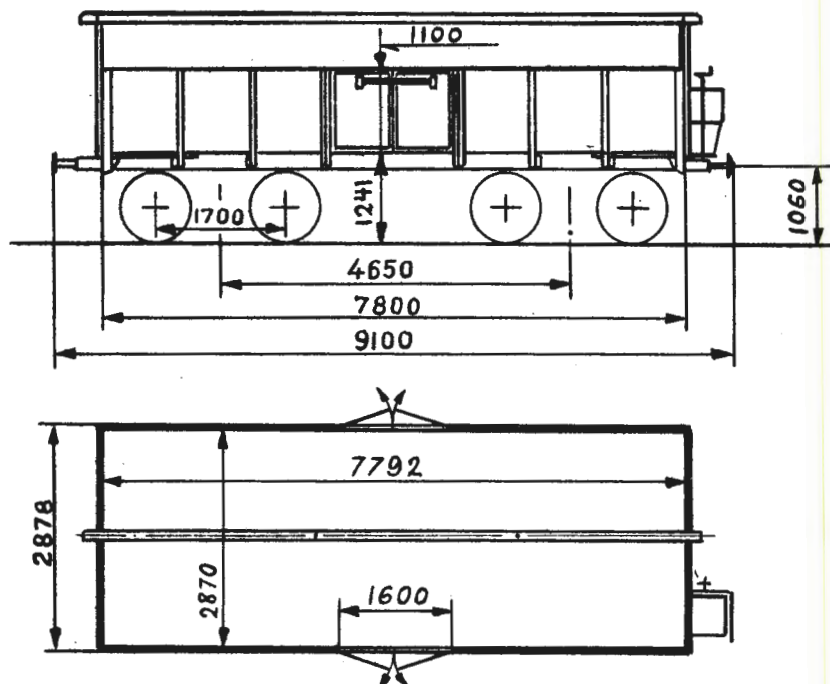

Omtrentlig vognvekt 15,0-15,5 t
 " last 30,5 t
 Gulvflate 22,4 m²
 Rominnhold 24,6 m³
 Hovedtegning 6199

KASSEVOGN

Vogn nr.	Fabr.	Byggeår	Merknad	Vogn nr.	Fabr.	Byggeår	Merknad
23701	SME	49	1)	23717	SME	49	1)
23702	"	"	1)	23718	"	"	1)
23703	"	"	1)	23719	"	"	1)
23704	"	"	1)	23720	"	"	1)
23705	"	"	1)	23721	"	"	1)
23706	"	"	1)	23722	"	"	1)
23707	"	"	1)	23723	"	"	1)
23708	"	"	1)	23724	"	"	1)
23709	"	"	1)				
23710	"	"	1)				
23711	"	"	1)				
23712	"	"	1)				
23713	"	"	1)				
23714	"	"	1)				
23715	"	"	1)				

1) Presenningsbom og svingbare endevegger.

Lf3

TYPE 1

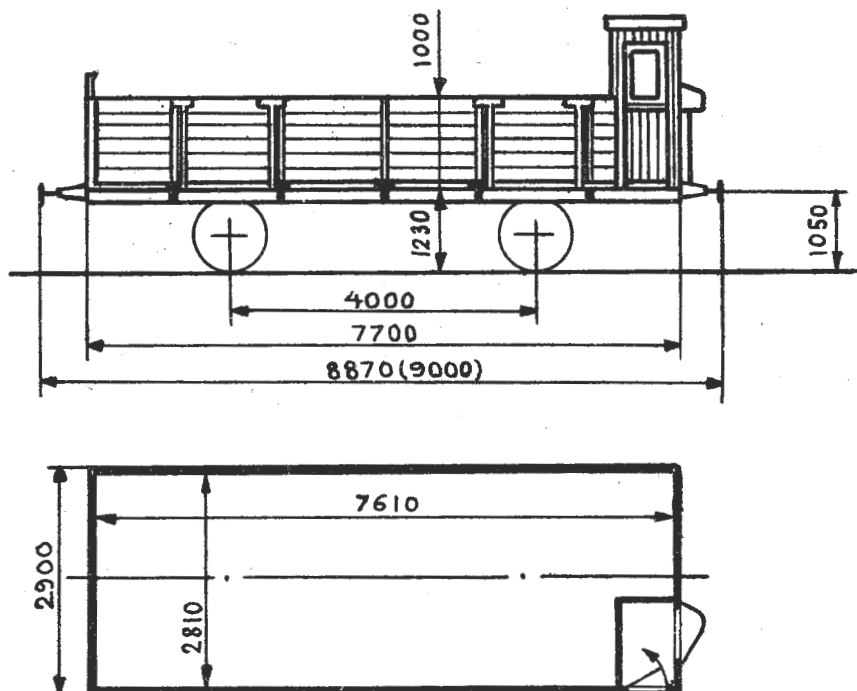

Omtrentlig egenvekt	8,5	t.
" last	14,5	t.
Gulvflate	20,5	m ²
Rominhold	20,4	m ³
Hovedtegning	578	

KASSEVOGN

Vogn nr.	Fabr.	Byggeår	Merknad	Vogn nr.	Fabr.	Byggeår	Merknad
13001	Skb	01					
13002	"	"					
13077	Edf	17					
13078	"	"					
13079	"	"					
13084	Str	22					
13085	"	"					

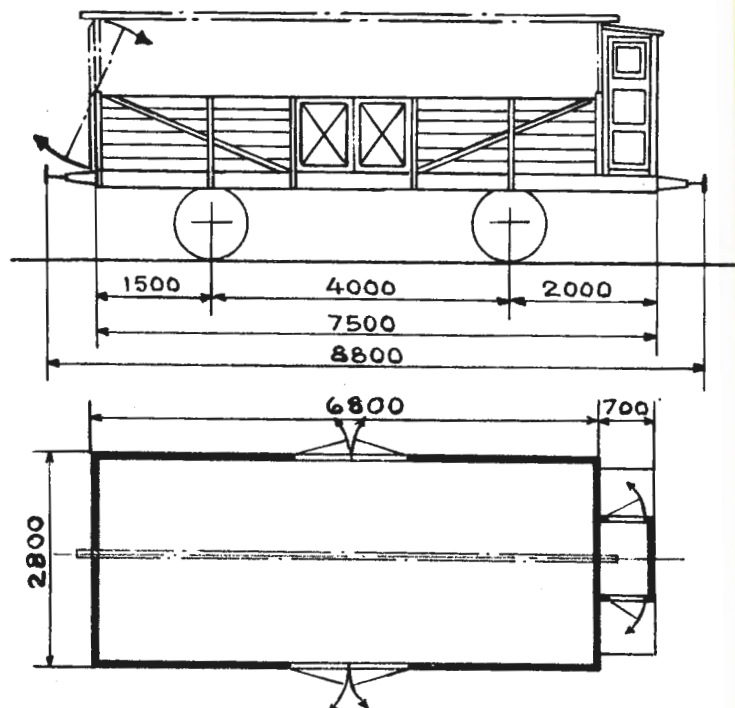

Bæreevne

A	B	C
21,0t	21,0t	

Omtrentlig vognvekt 8,0-10,0 t₂
 Gulvflate 18,4 m²
 Rominnhold 18,4 m³
 Hovedtegning Vognene er innkjøpt fra Tyskland i 1916

KASSEVOGN

Vogn nr.	Fabr.	Byggeår	Merknad	Vogn nr.	Fabr.	Byggeår	Merknad
✓ 11396							
11399							
32350							
32628							

Lgl

TYPE 1

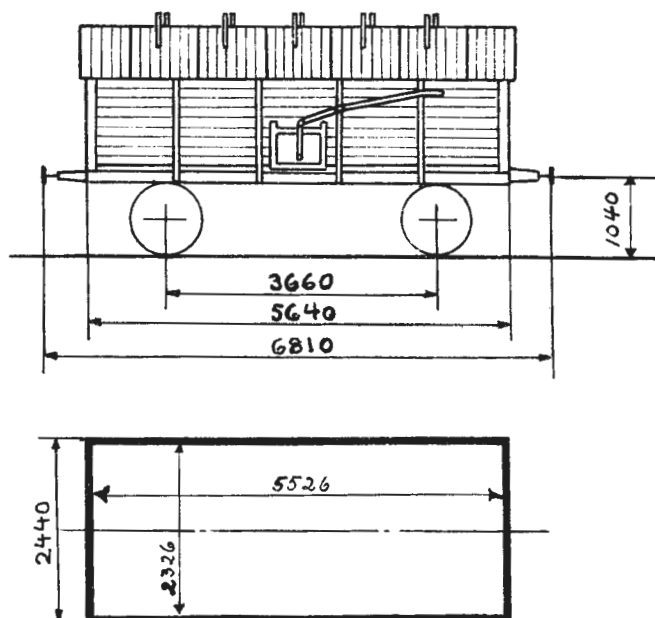

Omtrentlig vognvekt 7,0 t
 " last 10,5 t₂
 Gulvflate 12,8-12,9 m²
 Rominnhold 14,0-14,2 m³
 Hovedtegning 401, 606 eller ukjent

GJØDSELVOGN

Vogn nr.	Fabr.	Byggear	Merknad	Vogn nr.	Fabr.	Byggear	Merknad
2303	Str	02	H-tegn. 606				
2304	"	"					
2313	"	"					
2331	Oslo	99	H-tegn. 401				
2349	"	98					
11450	Skb	00	H-tegn. ukjent				

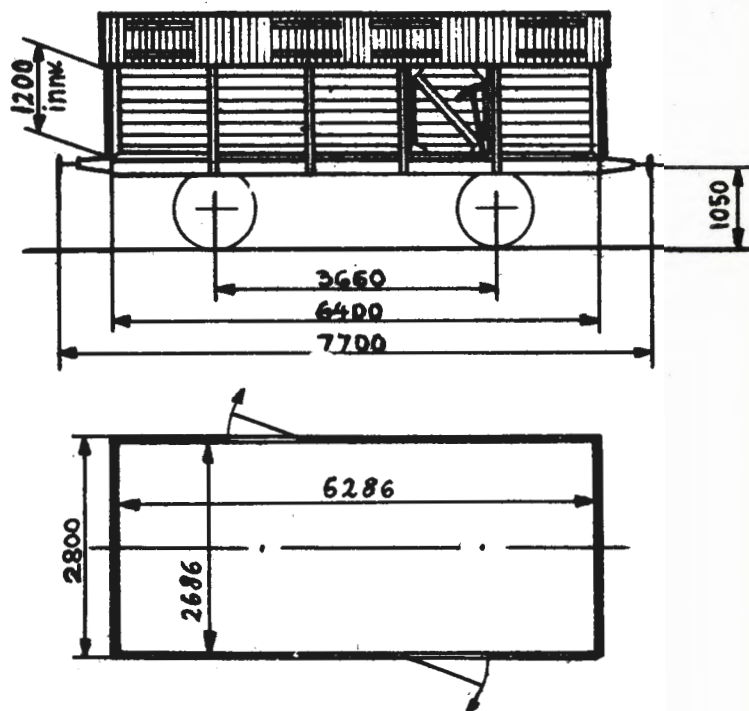

Omtrentlig vognvekt	8,0 t
" last	15,0 t
Gulvflate	16,9 m ²
Rominhold	20,3 m ³
Hovedtegning	2160

GJÖDSELVOGN

Vogn nr.	Fabr.	Byggeår	Merknad	Vogn nr.	Fabr.	Byggeår	Merknad
9808	Str	22					
9810	"	"					

Lk1

TYPE 1

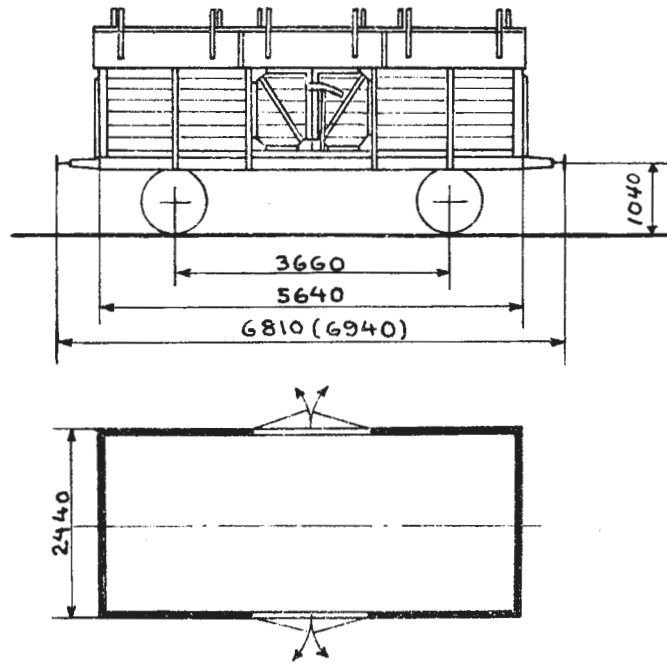

Bæreevne

A	B	C
11,0t	11,0t	

Omtrentlig vognvekt 6,5- 7,0 t
 Gulvflate 12,9-13,0 m²
 Rominnhold 13,0-15,0 m³
 Hovedtegning 911, 606+Drm 1359
 eller 616+4181

KALKVOGN

Vogn nr.	Fabr.	Byggeår	Merknad	Vogn nr.	Fabr.	Byggeår	Merknad
5166	Skb	09	H-tegn. 911				
15695	Edf	08	H-tegn. 616+4181				
15961 15965	Str "	05 "	H-tegn. 606+Drm 1359				

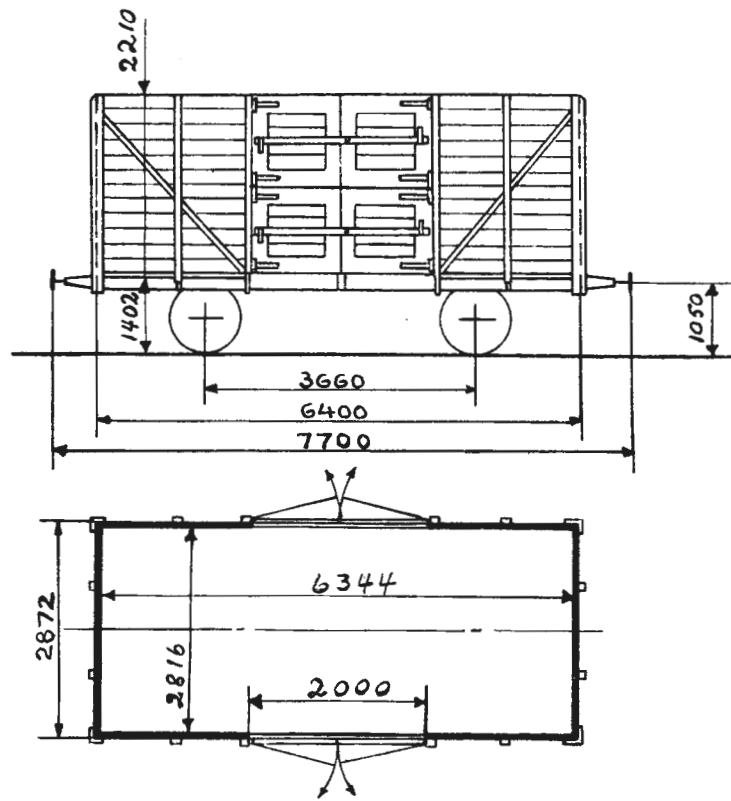

Omtrentlig vognvekt 6,5 t
 " bæreevne 11,0 t
 Gulvflate 17,8 m²
 Rominnhold 40,0 m³
 Hovedtegning 556 + 3388

TREKULLVOGN

Vogn nr.	Fabr.	Byggeår	Merknad	Vogn nr.	Fabr.	Byggeår	Merknad
7610	Skb	01					

Lt 2
TYPE 3

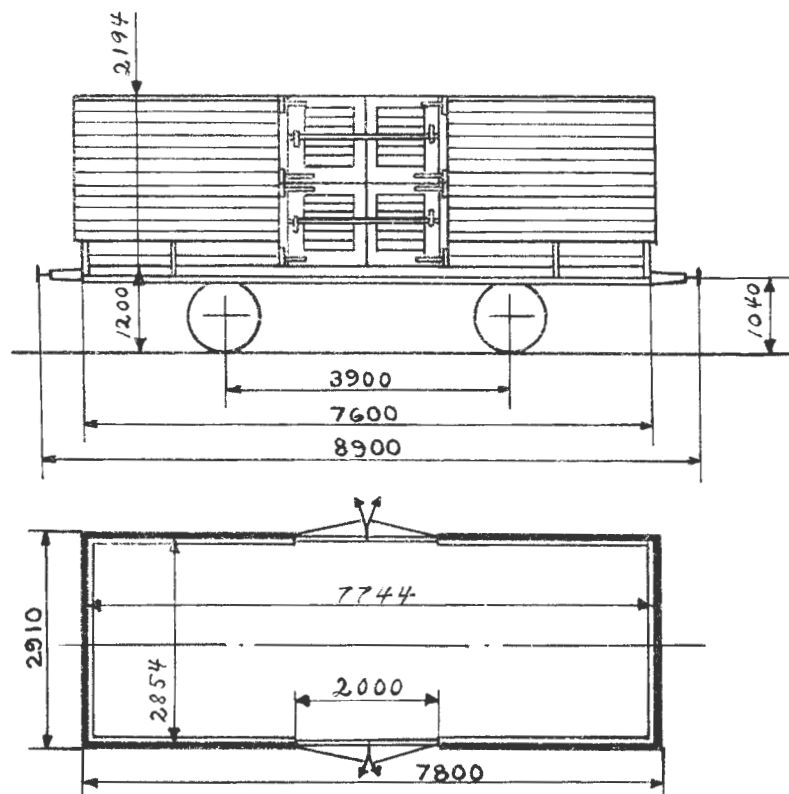

Bæreevne

A	B	C
11,0t	11,0t	

Omtrentlig vognvekt 6,5- 8,0 t
 Gulvflate 18,9 m²
 Rominnhold 45,7 m³
 Hovedtegning 815 + 3858

TREKULLVOGN

Vogn nr.	Fabr.	Byggeår	Merknad	Vogn nr.	Fabr.	Byggeår	Merknad
7616	Str	08		7658	Str	08	
7619	"	"		7662	"	"	
7620	"	"		7665	"	"	
7624	"	"		7666	"	"	
7627	"	"		7671	"	"	
7628	"	"		7673	"	"	
7629	"	"		7683	"	"	
7630	"	"		7687	"	10	
7637	"	"		7688	"	08	
7639	"	"		7694	"	10	
7641	"	"		7700	AaB	09	
7644	"	"		7702	"	"	
7645	"	"		7704	"	"	
7649	"	"		7714	Str	07	
7654	"	"		7718	AaB	09	

Vogn nr.	Fabr.	Byggeskr.	Merknad	Vogn nr.	Fabr.	Byggeskr.	Merknad
7725	Str.	08					
7726	"	"					
7729	"	"					
7730	"	"					
7732	"	"					
7733	"	"					
7734	"	"					
7735	"	"					
7736	"	"					
7743	"	"					
7745	"	"					

Lt4

TYPE 1

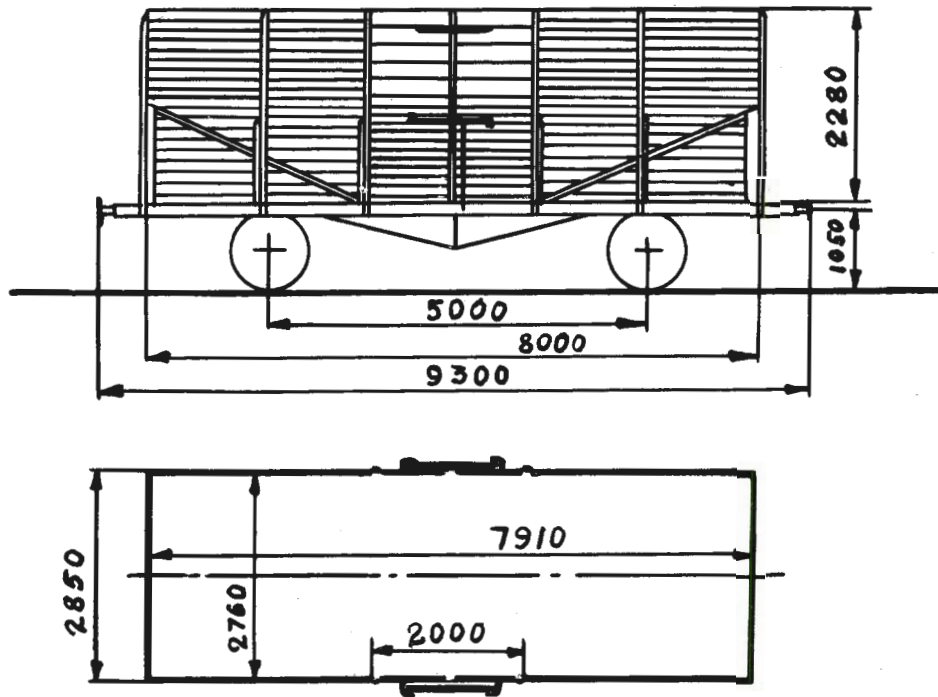

Bæreevne

A	B	C
20,0t	20,0t	

Omtrentlig vognvekt 9,0-10,0 t²
 Gulvflate 21,4 m²
 Rominnhold 48,0 m³
 Hovedtegning 3989 + skisse
 nr. 1518

TREKULLVOGN

Vogn nr.	Fabr.	Byggeår	Merknad	Vogn nr.	Fabr.	Byggeår	Merknad
7100	Skb	36		7115	Str	39	
7101	Str	37		7116	"	37	
7102	Edf	"		7117	Skb	36	
7103	Str	39		7118	Str	37	
7104	"	37		7119	"	"	
7105	Edf	"		7120	"	"	
7106	Skb	36		7121	"	"	
7107	Edf	37		7122	"	"	
7108	Str	"		7123	Edf	"	
7109	"	"		7124	Str	"	
7110	"	"		7125	Skb	36	
7111	"	38		7126	Edf	37	
7112	Skb	36		7127	Skb	36	
7113	Str	37		7128	Edf	37	
7114	Skb	36		7129	Str	"	

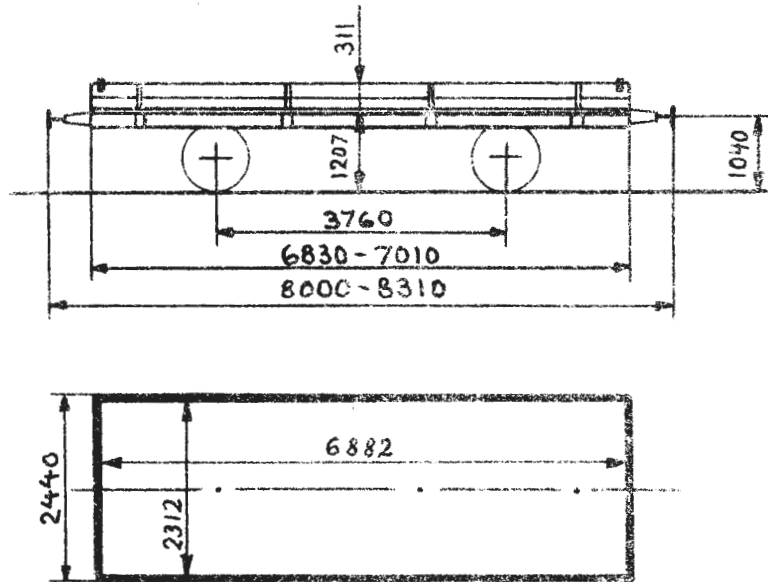

Bæreevne

A	B	C
12,0t	12,0t	

Omtrentlig vognvekt 5,0- 6,0 t
 Gulvflate 15,5-15,9 m²
 Rominnhold 4,8- 5,0 m³
 Hovedtegning 47, 400, Oslo dist-
 rikt 678, 876, B 97
 eller ukjent

GRUSVOGN

Vogn nr.	Fabr.	Byggeår	Merknad	Vogn nr.	Fabr.	Byggeår	Merknad
2267	Skb	00	H-tegn. 400	2373	Str	01	H-tegn. ukjent
2272	"	"					
2299	"	"	1)				H-tegn. Oslo dist- rikt 678
2362	Oslo	04	H-tegn. Oslo dist- rikt 678	2374	Skb	04	2)
2363	"	05	2)	2375	Oslo	"	2)
2365	Str	01	H-tegn. ukjent				H-tegn. ukjent
2366	Oslo	04	H-tegn. Oslo dist- rikt 678	2376	Str	01	
2368	"	"	2)	2384	Oslo	06	
2370	Skb	"	2)	2385	Str	01	
				2386	Oslo	06	
				2389	Str	01	
				2392	Oslo	06	

1) Omb. etter tegn. 538. 2) Har skruebremse.

Vogn nr.	Fabr.	Byggeår	Merknad	Vogn nr.	Fabr.	Byggeår	Merknad
2394	Oslo	04	H-tegn. Oslo dist- rikt 678	2582	Skb	89	
				2585	"	"	
				2598	Str	91	
2395	Str	01	H-tegn. ukjent				H-tegn. 400
2398	"	"		2656	Str	97	
				2677	"	98	
2442	Str	99	H-tegn. 400	2685	"	"	
2444	"	"		2702	"	"	1)
2447	"	"		2765	MMV	99	
2452	"	"		2771	"	"	
2453	"	"		2861	Str	00	1)
				2885	Skb	"	
2473	Skb	85	H-tegn. 47	3804	"	95	3)
2489	"	88		3806	"	"	3)
				3811	"	"	3)
				3812	"	"	3)
				3814	"	"	3)
				3818	"	"	3)
2496	Atl	74	H-tegn. ukjent	5277	Str	00	
2502	"	"		6142	Skb	02	
2507	"	"		6143	"	"	
2508	"	"		6146	"	"	
2510	"	"		6156	"	"	1)
2511	"	"		6166	"	"	
2513	"	"					
2515	"	"					
2517	"	"					H-tegn. 876
2519	"	"		6169	Skb	02	
2522	"	"					H-tegn. 400
2523	"	"		6303	Str	97	
2526	"	"		6319	"	"	
2535	"	"		6344	"	"	
2536	"	"		6345	"	"	
2538	"	"		6358	"	"	
				6366	"	"	
			H-tegn. 47	6378	Skb	00	1)
2551	Str	88					

1) Omb. etter tegn. 538. 3) Byggeår 1895 eller tidligere.

Vogn nr.	Fabr.	Byggekår	Merknad	Vogn nr.	Fabr.	Byggekår	Merknad
6383	Skb	00		10388	Skb	15	
(6394	"	"	1)	(10389	"	"	
			H-tegn. 47	10391	"	"	
7508	Str	92	1)	10392	"	"	
			H-tegn. 400	10394	"	"	
8551	MMV	95		10395	"	"	
8609	Str	99		10397	"	"	
			H-tegn. 876	10398	"	"	
8655	HJ	14	1)	10400	"	"	
8664	"	"					H-tegn. B 97
8667	"	"		11501	Str	00	
			H-tegn. 400	11502	"	"	
9501	Str	99		11503	"	"	
9503	"	"		11505	"	"	
9504	"	"		11507	"	"	
9505	"	"		11508	"	"	
9506	"	"		11509	"	"	
9508	"	"		11510	"	"	
9517	Skb	00		11511	"	"	
			H-tegn. 876	11512	"	"	
(10371	Skb	15		11513	"	"	
10373	"	"		11514	"	"	
10374	"	"		11515	"	"	
10375	"	"		11516	"	"	
10376	"	"		11517	"	"	
10377	"	"		11518	"	"	
10378	"	"		11519	"	"	
10379	"	"		11520	"	"	
10380	"	"		11521	"	"	
10381	"	"		11522	"	"	
10384	"	"		11524	"	"	
10385	"	"		11525	"	"	
	"	"		11526	"	"	
	"	"		11527	"	"	
	"	"		11529	"	"	

etter tegn. 38.

nr.	Str	H-tegn.	Vogn nr.	Febr	Byr	H-tegn.
11530	Str	00	16202	Edf	01	
		H-tegn. 400	16209	"	"	
12510	Str	00 2)	16212	"	"	
12513	"	" 2)	16239	"	"	
16001	"	99	16240	"	"	
		H-tegn. 47	16248	"	"	
16002	Str	92	16249	"	"	
		H-tegn. 400	16254	"	"	
16003	Str	99	16260	"	" 1)	
		H-tegn. 47	16272	"	06	
16005	KvB	93	16295	"	"	
16006	"	"				H-tegn. 876
16008	Str	98	16450	AaB	12	
16012	"	93	16457	"	"	
		H-tegn. 400	20800	Skb	21 1)	
16018	Str	99	20802	4)	"	
16020	"	"	20803	"	"	
		H-tegn. 47	20804	"	"	
16021	KvB	93	20806	"	"	
16022	Str	"	20807	"	"	
		H-tegn. 400	20808	"	"	
16024	Str	99	20809	"	"	
		H-tegn. 47	20811	"	"	
16025	Str	92	20812	Skb	"	
		H-tegn. 400	20813	4)	"	
16116	Edf	00	20814	Skb	" 1)	
16148	"	"	20815	4)	"	
16155	"	"	20816	Skb	"	
16156	"	"	20817	4)	"	
16167	"	"	20819	Edf	22	
16187	"	01	20820	"	"	
			20822	"	"	
			20824	"	"	
			20825	"	"	
			20826	"	"	

Vogn nr.	Fabr.	Byggeår	Merknad	Vogn nr.	Fabr.	Byggeår	Merknad
20830	Edf	22					
20832	"	"					
20834	4)	"					
20835	Edf	"					
20838	4)	"					
20840	Edf	"					
20841	"	"	1)				
20845	4)	"					
20847	"	"					
20848	Edf	22					
20849	"	"					

1) Omb. etter tegn. 538. 4) Edf/Skb.

M1

TYPE 2

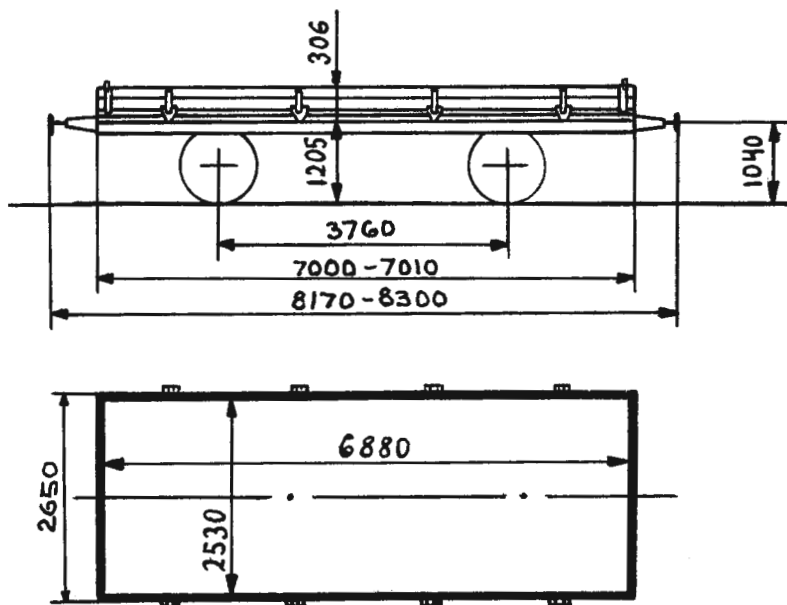

Bæreevne

A	B	C
12,0t	12,0t	

Omtrentlig vognvekt 5,5- 6,0 t
 Gulvflate 17,4 m²
 Rominnhold 4,9- 5,3 m³
 Hovedtegning 614 eller 1362

GRUSVOGN

Vogn nr.	Fabr.	Byggear	Merknad	Vogn nr.	Fabr.	Byggear	Merknad
			H-tegn. 1362	8259	Edf	12	
8244	Edf	12		8260	"	"	
8245	"	"		8261	"	"	
8246	"	"		8262	"	"	
8247	"	"		8263	"	"	
8248	"	"		8265	"	"	
8249	"	"		8266	"	"	
8250	"	"		8267	"	"	
8251	"	"		8268	"	"	
8252	"	"		8269	"	"	
8253	"	"		8270	"	"	
8254	"	"		8271	"	"	
8255	"	"		8272	"	"	
8256	"	"		8273	"	"	
8258	"	"		8274	"	"	

Vogn nr.	Fabr.	Byggeår	Merknad	Vogn nr.	Fabr.	Byggeår	Merknad
8275	Edf	12		14452	Edf	05	
8276	"	"		14453	"	"	
8277	"	"		14454	"	"	
8278	"	"		14455	"	"	
8279	"	"		14456	"	"	
8280	"	"		14457	"	"	
8281	"	"		14458	"	"	
8282	"	"		14460	"	"	
				14461	"	"	
14401	Str	04	H-tegn. 614	14462	"	"	
14402	"	"		14463	"	"	
14403	"	"		14464	"	"	
14404	"	"		14465	"	"	
14405	"	"		14467	"	"	
14406	"	"					
14407	"	"		20501	Edf	13	H-tegn. 1362
14408	"	"		20502	"	"	
14409	"	"		20503	"	"	
14410	"	"		20505	"	"	
14412	"	"		20507	"	"	
14413	"	"		20508	"	"	
14414	"	"		20509	"	"	
14419	"	"	1)	20510	"	"	
14423	Skb	05		20511	"	"	
14424	"	"		20512	"	"	
14426	"	"		20513	"	"	
14428	"	"		20514	"	"	
14430	"	"		20515	"	"	
14431	"	"		20516	"	"	
14433	"	"		20517	"	"	
14434	"	"		20519	"	"	
14435	"	"		20520	"	"	
14440	"	"	1)	20522	"	"	
14446	Edf	06	1)	20523	"	"	
14450	"	05		20524	"	"	
				20527	"	12	1)

1) Har skruebremse.

M1

TYPE 3

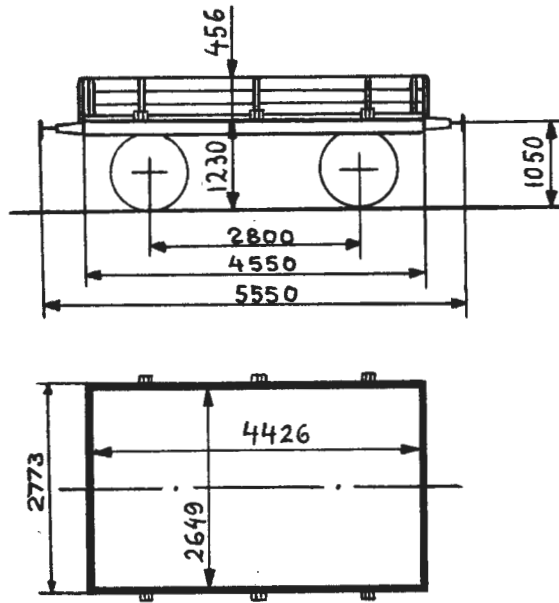

Omtrentlig vognvekt 7,0 t
" last 16,5 t
Gulvflate 11,8 m²
Rominhold 5,3 m³
Hovedtegning Skabo 199

GRUSVOGN

Vogn nr.	Fabr.	Byggeår	Merknad	Vogn nr.	Fabr.	Byggeår	Merknad
23389	Skb	08					

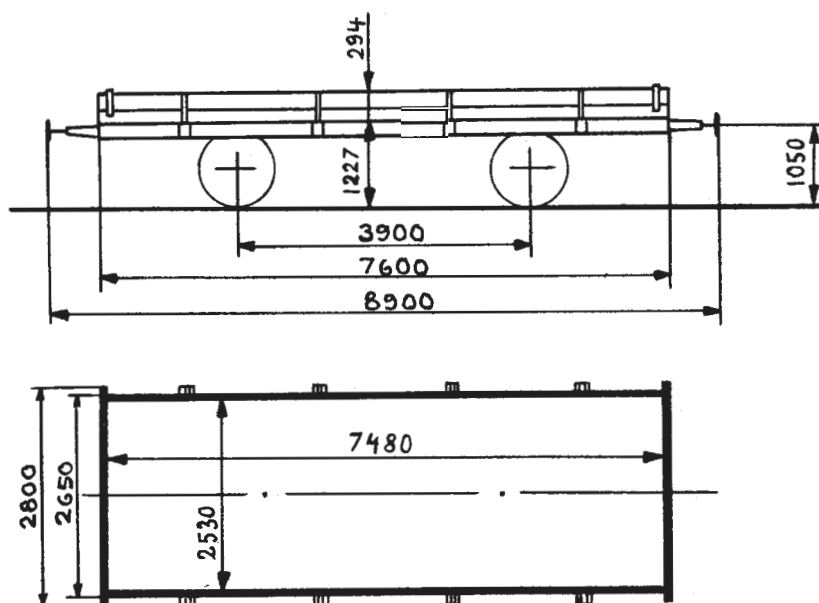

Bæreevne

A	B	C
11,0t	11,0t	

Omtrentlig vognvekt 7,0 t
 Gulvflate 19,0 m²
 Rominnhold 5,0 m³
 Hovedtegning 1255, 1334+1849
 eller 1334+1850

GRUSVOGN

Vogn nr.	Fabr.	Byggeår	Merknad	Vogn nr.	Fabr.	Byggeår	Merknad
5495	Skb	15	H-tegn. 1334+1849 ¹⁾ 2) 3)	17519	Str	14	
5498	"	"	3)	23008	AaB	"	2)
				23009	"	"	2)
				23010	"	"	2)
8221	Str	11	H-tegn. 1255	23011	"	"	2)
				23012	"	"	2)
17510	Str	14	H-tegn. 1334+1850	23014	"	"	2)
17511	"	"		23015	"	"	2)
17512	"	"		23016	"	"	
17513	"	"		23017	"	"	2)
17515	"	"		23018	"	"	
17516	"	"		23019	"	"	
17517	"	"		23020	"	"	
17518	"	"		23021	"	"	
				23022	"	"	

1) Bremsarhus som vist på tegn. 1849 er fjernet. 2) Platekledt varegulv. 3) Har skruebremse.

Vogn nr.	Fabr.	Byggeår	Merknad	Vogn nr.	Fabr.	Byggeår	Merknad
23023	AaB	14					H-tegn. 1334+1849 ¹⁾
23025	"	"		23461	Skb	15	3)
23026	"	"		23468	"	"	3)
23027	"	"		23475	"	"	3)
23028	"	"		23478	"	"	3)
23029	"	"		23484	"	"	3)
23030	"	"		23493	"	"	3)
23031	"	"					
23032	"	"					
23033	"	"					
23034	"	"					
23035	"	"					
23036	"	"					
23037	"	"					
23038	Str	"					
23039	"	"					
23040	"	"					
23442	"	"					
34443	"	"					
23444	"	"					
23445	"	"					
23446	"	"					
23447	"	"					
23448	"	"					
23449	"	"	2)				
23450	"	"	2)				
23451	"	"	2)				
23452	"	"	2)				
23453	"	"	2)				
23454	"	"	2)				
23455	"	"	2)				
23456	"	"	2)				
23457	"	"	2)				
23458	"	"	2)				

1) Bremserhus som vist på tegn. 1849, er fjernet. 2) Platekledt varegulv. 3) Har skruebremse.

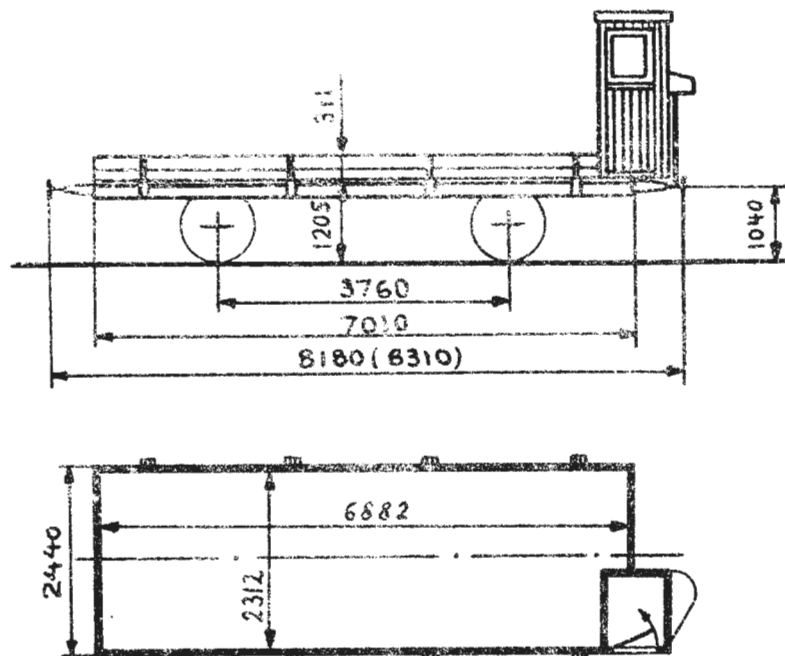

Bæreevne

A	B	C
12,0t	12,0t	

Omtrentlig vognvekt

6,0 t

Gulvflate

15,1 m²

Rominhold

4,7 m³

Hovedtegning Oslo distrikt 678

GRUSVOGN

Vogn nr.	Fabr.	Byggeår	Merknad	Vogn nr.	Fabr.	Byggeår	Merknad
2364	Oslo	04					
2367	Skb	"					
2369	"	"					
2377	Oslo	05					
2378	"	"					
2380	"	04					
2382	Skb	"					
2383	"	"					
2387	"	"					
2388	Oslo	05					
2390	"	"					
2391	"	"					
2397	"	04					
3816	Skb	1)					

1) Bygget för 1895.

Mf1

TYPE 2

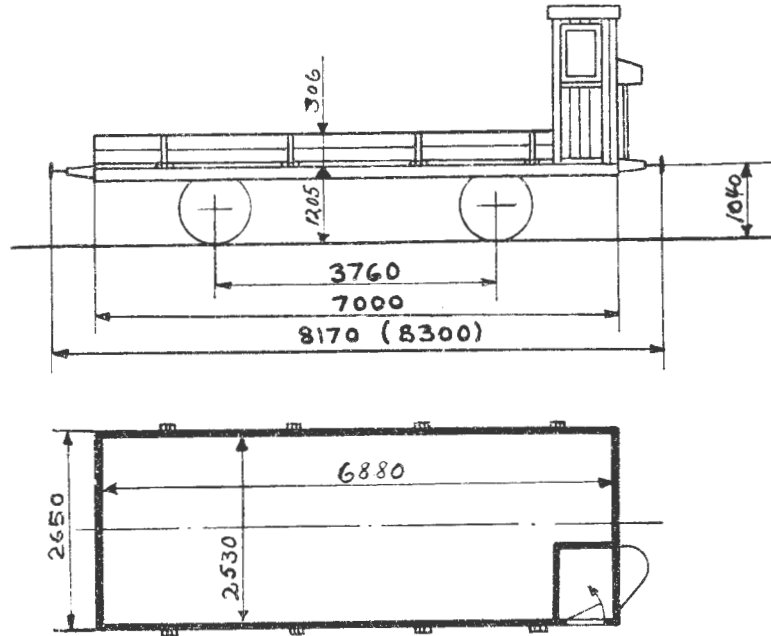

Bæreevne

A	B	C
12,0t	12,0t	

Omtrentlig vognvekt 6,0 t
 Gulvflate 16,6 m²
 Rominnhold 4,7 m³
 Hovedtegning 614 eller 1362

GRUSVOGN

Vogn nr.	Fabr.	Byggear	Merknad	Vogn nr.	Fabr.	Byggear	Merknad
			H-tegn. 1362	14449	Edf	06	
8283	Str	12					H-tegn. 1362
8285	"	"		20525	Edf	12	
8287	"	"		20526	"	"	
8288	"	"		20528	"	"	
8289	"	"		20529	"	"	
			H-tegn. 614	20530	"	"	
14416	Str	04					
14417	"	"					
14418	"	"					
14420	"	"					
14438	Skb	05					
14441	"	"					
14442	"	"					
14443	Edf	06					

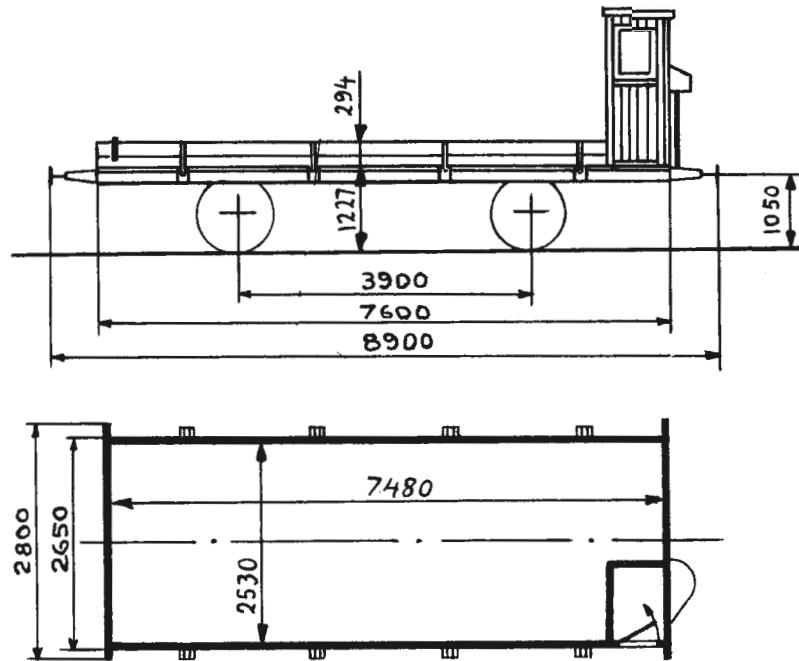

Bæreevne

A	B	C
11,0t	11,0t	

Omtrentlig vognvekt 7,0-11,0 t
 Gulvflate 18,3 m²
 Rominnhold 4,8 m³
 Hovedtegning 1334 + 1849

GRUSVOGN

Vogn nr.	Fabr.	Byggeår	Merknad	Vogn nr.	Fabr.	Byggeår	Merknad
✓ 5490	Skb	15		23470	Skb	15	
5491	"	"		23474	"	"	
5493	"	"	1)	23476	"	"	
✓ 5496	"	"	1)	23481	"	"	
5500	"	"	1)	23482	"	"	
17521	Str	"		23484	"	"	
17525	"	"		23489	"	"	
17526	"	"		23490	"	"	
17527	"	"		23495	"	"	
23459	Skb	"					
23462	"	"					
23464	"	"					
23467	"	"					
23468	"	"					
23469	"	"					

1) Platekledt varegulv.

Ms3

TYPE 1

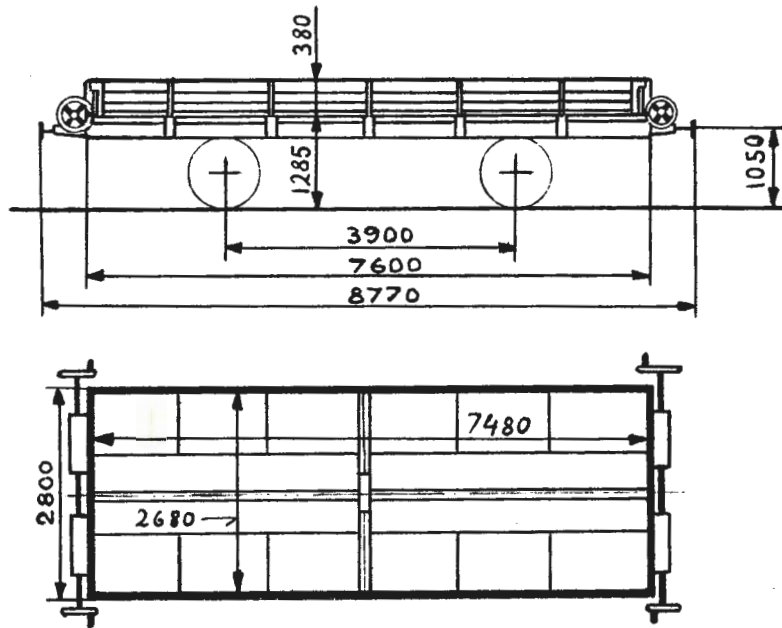

Omtrentlig vognvekt	8,5- 9,0 t
" last	14,0-14,5 t
Gulvflate	19,8 m ²
Rominnhold	7,6 m ³
Hovedtegning	1350

SPESIAL GRUSVOGN

Vogn nr.	Fabr.	Byggeår	Merknad	Vogn nr.	Fabr.	Byggeår	Merknad
8222	Str	12					
8223	"	"					
8229	"	"					
8232	"	"					
8233	"	"	1)				
8235	"	"					
8237	"	"					

1) Har skrubremse.

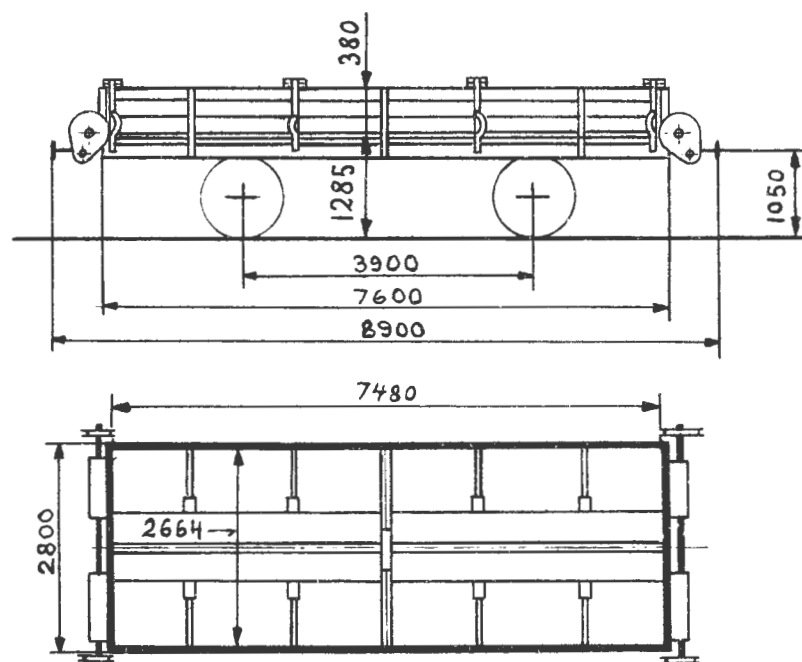

Omtrentlig vognvekt 9,0 t
 " last 14,0 t₂
 Gulvflate 19,3 m₂
 Rominnhold 7,5 m³
 Hovedtegning 2253

SPESIAL GRUSVOGN

Vogn nr.	Fabr.	Byggeår	Merknad	Vogn nr.	Fabr.	Byggeår	Merknad
2126	Str	21		15872	Str	22	
2127	"	"		15873	"	"	
2128	"	"		15874	"	"	
2130	"	"		15875	"	"	
2131	"	"		15876	"	"	
2132	"	"		15877	"	"	
2133	"	"		15878	"	"	
2134	"	"		15879	"	"	
2135	"	"		15880	"	"	
6987	"	"		15881	"	"	
6989	"	"		15882	"	"	
6990	"	"		15883	"	"	
6993	"	"	1)	15884	"	"	
6994	"	"	1)	15885	"	"	
15871	"	22		15886	"	"	

1) Har skruebremse.

Ms3
TYPE 2

Vogn nr.	Fabr.	Byggeår	Merknad	Vogn nr.	Fabr.	Byggeår	Merknad
15887	Str	22					
15889	"	"					
15890	"	"					
15891	"	"					
15892	"	"					
15899	"	"	1)				

1) Har skruebremse

Trykk nr. 752 1.1.63

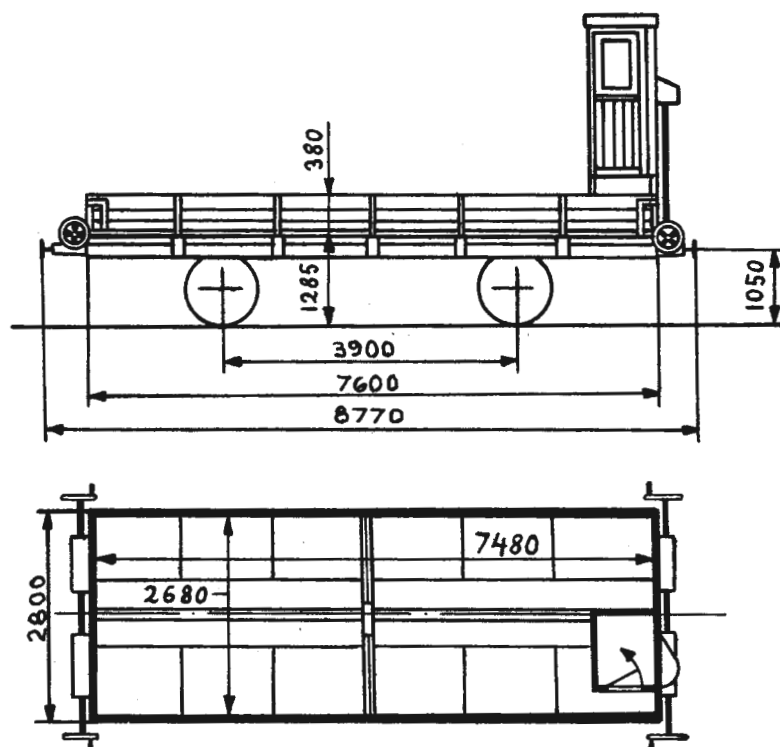

Omtrentlig vognvekt	9,0 t
" last	14,0 t
Gulvflate	19,8 m ²
Rominhold	7,6 m ³
Hovedtegning	1350

SPECIAL GRUSVOGN

Vogn nr.	Fabr.	Byggeår	Merknad	Vogn nr.	Fabr.	Byggeår	Merknad
8224	Str	12					
8234	"	"					
8238	"	"					
8239	"	"					
8240	"	"					

MSf 3

TYPE 2

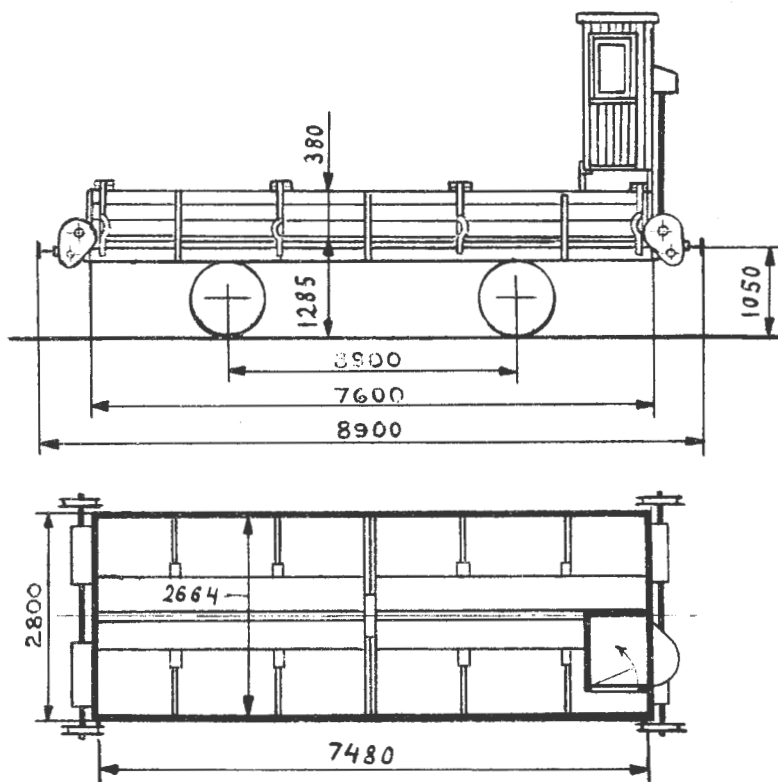

Omtrentlig vognvekt	9,5 t
" last	13,5 t
Gulvflate	19,3 m ²
Rominnhold	7,5 m ³
Hovedtegning	2253 + 2449

SPESIAL GRUSVOGN

Vogn nr.	Fabr.	Byggeår	Merknad	Vogn nr.	Fabr.	Byggeår	Merknad
6991	Str	21					
6992	"	"					
6993	"	"					
6994	"	"					
6995	"	"					
15893	"	22					
✓15894	"	"					
✓15895	"	"					
15896	"	"					
15897	"	"					
✓15898	"	"					
15900	"	"					

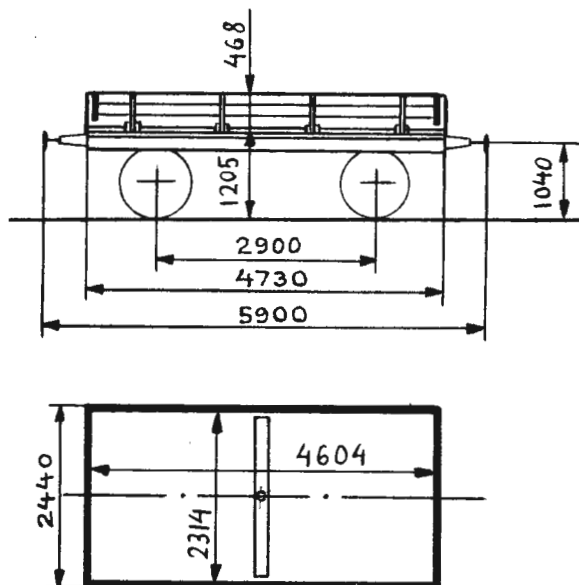

Omtrentlig vognvekt 5,5 t
 " last 11,5 t
 Gulvflate 10,6 m²
 Rominnhold 4,9 m³
 Hovedtegning 245

GRUS- OG TÖMMERVOGN

Vogn nr.	Fabr.	Byggear	Merknad	Vogn nr.	Fabr.	Byggear	Merknad
6150	Skb	02					
8212	Str	01					
12404	Wmr	"					

MK3

TYPE 1

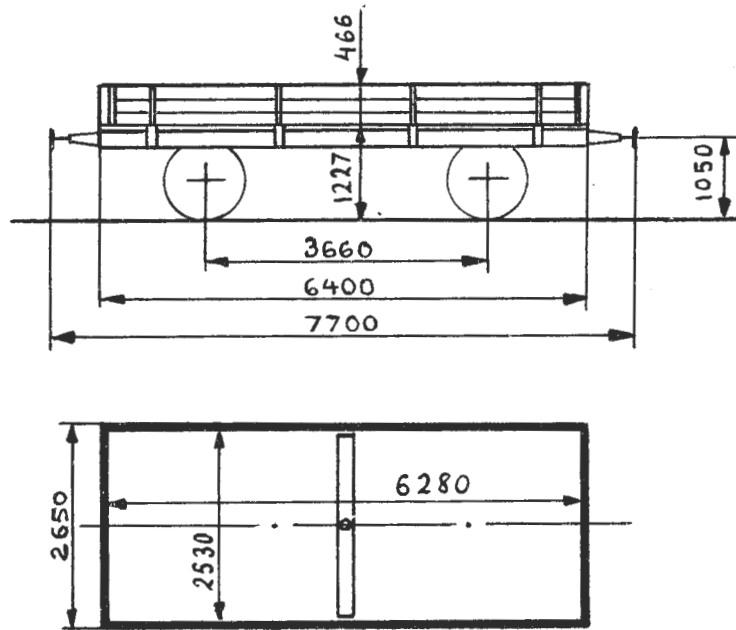

Omtrentlig vognvekt	7,0- 7,5	t
" last	10,5	t
Gulvflate	15,9	m ²
Rominhold	7,4	m ³
Hovedtegning	2244	

GRUS- OG TÖMMERVOGN

Vogn nr.	Fabr.	Byggeår	Merknad	Vogn nr.	Fabr.	Byggeår	Merknad
20231	AaB	23		20248	AaB	23	
20232	"	"		20249	"	"	
20233	"	"		20250	"	"	
20234	"	"					
20235	"	"					
20236	"	"					
20238	"	"					
20239	"	"					
20240	"	"					
20241	"	"					
20242	"	"					
20243	"	"					
20244	"	"					
20245	"	"					
20246	"	"					

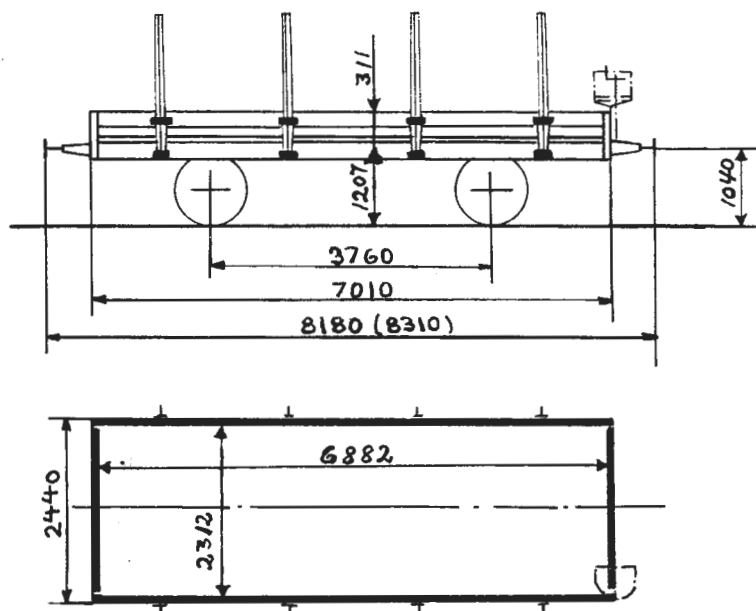

Omtrentlig vognvekt 5,5- 7,0 t
 " last 10,5-11,5 t₂
 Gulvflate 15,9 m₂
 Rominnhold 5,0 m₃
 Hovedtegning 47, 400, 876 eller ukjent

STAKEVOGN

Vogn nr.	Fabr.	Byggeår	Merknad	Vogn nr.	Fabr.	Byggeår	Merknad
1818	Str	91	H-tegn. ukjent	3979	Skb	82	H-tegn. ukjent
2286	Skb	00	H-tegn. 400	4053	Str	81	1)
2440	Str	99		5222	"	78	
2573	Skb	89	H-tegn. 47	6326	Str	97	H-tegn. 400
2577	"	"		6340	"	"	
2592	Str	91		6398	Skb	00	
2687	Str	98	H-tegn. 400	6402	"	"	
2695	"	"		7502	Str	92	H-tegn. 47
2877	Skb	00		7535	"	"	
				8584	Str	97	H-tegn. 400

1) Kasse for vedtransport.

N1
TYPE 1

Vogn nr.	Fabr.	Byggeår	Merknad	Vogn nr.	Fabr.	Byggeår	Merknad
8597	Str	99					
10740	Atl	78	H-tegn. ukjent				
10996	AaB	12	H-tegn. 876				
12525	Str	00	H-tegn. 400				
16164	Edf	"					
16172	"	"					
16225	"	01					
16270	"	06					
20846	Edf	22	H-tegn. 876				

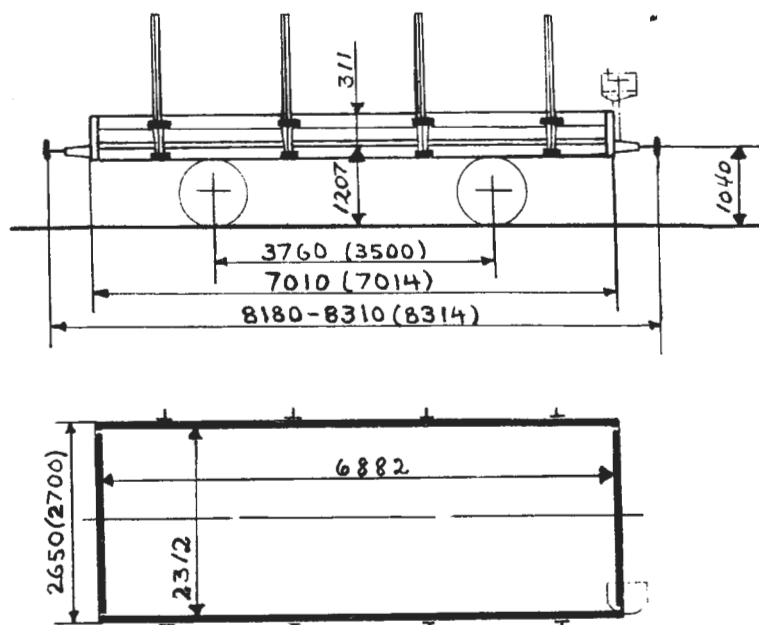

Omtrentlig vognvekt 5,5-12,0 t
 " last 10,5-11,0 t
 Gulvflate 17,4-17,7 m²
 Rominnhold 5,3 m³
 Hovedtegning 614 eller ukjent

STAKEVOGN

Vogn nr.	Fabr.	Byggeår	Merknad	Vogn nr.	Fabr.	Byggeår	Merknad
			H-tegn. ukjent	1920	Str	97	
1675	Str	83		1923	"	"	
1688	"	84		1959	"	98	
1696	"	"		1963	"	"	
1698	"	"		1973	"	"	
1714	Skb	88		3955	Atl	76	
1739	Str	90		3958	"	"	
1742	"	"		3987	Oslo	15	
1757	"	"		4018	"	16	
1758	"	"		4023	"	"	
1851	"	78		4088	"	14	
1860	"	"		4094	"	15	
1878	"	"					H-tegn. 614
1879	"	"		10834	Str	01	
1905	"	95					

N1
TYPE 2

Vogn nr.	Fabr.	Byggear	Merknad	Vogn nr.	Fabr.	Byggear	Merknad
11665	Str	99	H-tegn. ukjent				
11680	"	"					
11688	"	"					

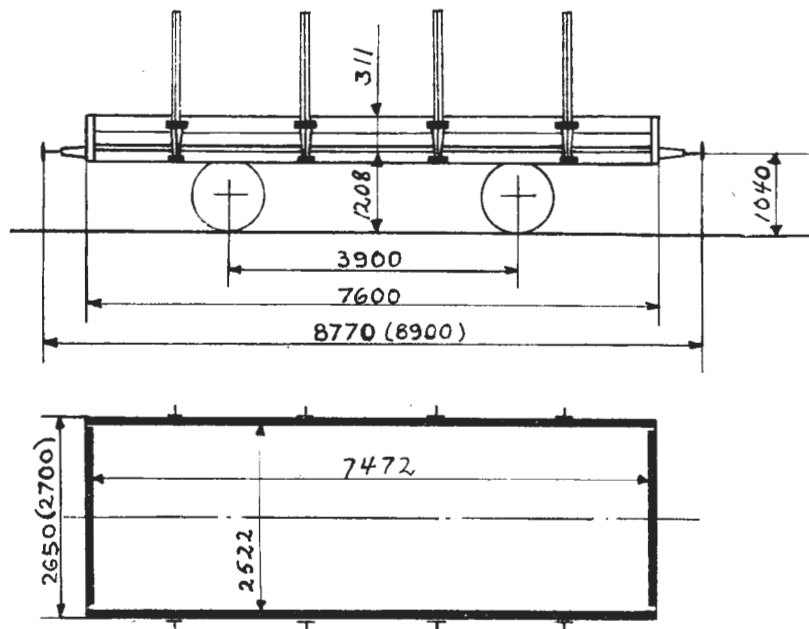

Omtrentlig vognvekt 5,5- 9,0 t
 " last 11,0 t
 Gulvflate 18,8-19,2 m²
 Rominnhold 5,6- 5,9 m³
 Hovedtegning 690, 815, B 183
 eller ukjent

STAKEVOGN

Vogn nr.	Fabr.	Byggeår	Merknad	Vogn nr.	Fabr.	Byggeår	Merknad
			H-tegn. 815	4172	Str	03	
2402	Str	08		4177	"	"	
2403	"	"					H-tegn. 815
2410	"	"		4211	Str	08	
2413	"	"		4213	"	"	
			H-tegn. ukjent	5320	"	10	
2514	Oslo	12		5324	"	"	
2516	"	"		6426	"	08	
2524	"	13		6431	"	"	
			H-tegn. 690	6435	"	"	
2806	Str	03		6440	"	"	
2809	"	"		6448	"	"	
2810	"	"		6450	"	"	
4170	"	"		6454	"	"	

N2
TYPE 1

Vogn nr.	Fabr.	Byggeår	Merknad	Vogn nr.	Fabr.	Byggeår	Merknad
7549	AaB	09		11882	Skb	10	
7554	"	"		11883	"	"	
7562	"	"		11885	"	"	
7571	"	"		11886	"	"	
7573	"	"		11888	"	"	
9529	Str	08		11890	"	"	
10851	"	07		11892	"	"	
10856	"	"		11893	"	"	
10857	"	"		11895	"	"	
10868	"	"		11896	"	"	
10869	"	"		11899	"	"	
10871	"	"		11900	"	"	
10872	"	"					
10875	"	"					
10876	"	"					
10891	AaB	09					
10892	"	"					
10895	"	"					
10898	"	"					
10900	"	"					
10906	"	"					
10912	"	"					
			H-tegn. B 183				
11714	Str	07					
11720	"	"					
11722	"	"					
11732	AaB	08					
11738	"	"					
11750	"	"					
11759	"	"					
11761	"	"					
11765	Str	10					
11768	"	"					
11769	"	"					
11774	"	"					

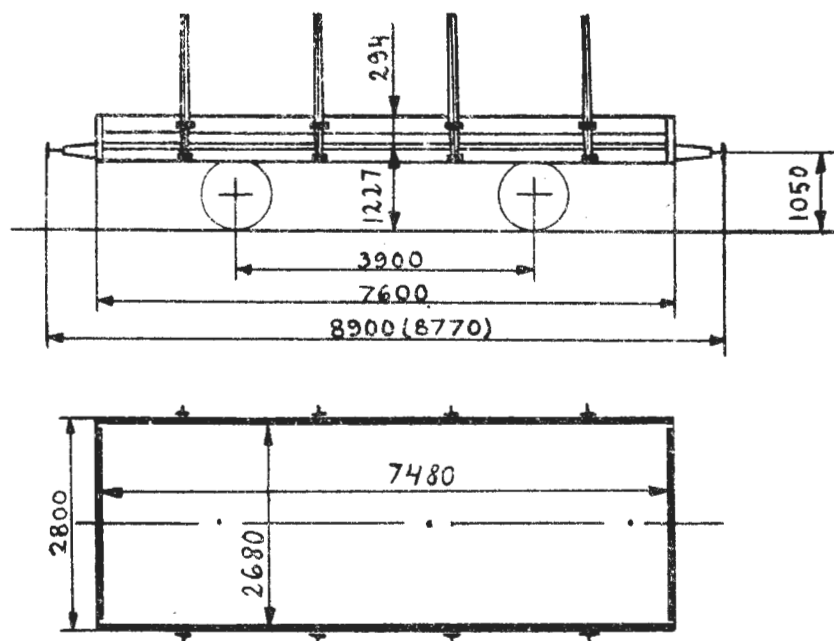

Bæreevne

A	B	C
11,5t	11,5t	

Omtrentlig vognvekt 6,0-6,5 t
 Gulvflate 20,0 m²
 Rominnhold 5,8 m³
 Hovedtegning 1334

STAKEVOGN

Vogn nr.	Fabr.	Byggeår	Merknad	Vogn nr.	Fabr.	Byggeår	Merknad
3634	Edf	24		3657	Edf	24	
3635	"	"		3822	Str	20	
3636	"	"		3823	"	"	
3638	"	"		3824	"	"	
3639	"	"		3825	"	"	
3640	"	"		3826	"	"	
3641	"	"		3827	"	"	
3642	"	"		3828	"	"	
3644	"	"		3829	"	"	
3647	"	"		3833	"	"	
3649	"	"		3834	"	"	
3651	"	"		3835	"	"	
3652	"	"		3836	"	"	
3653	"	"		3837	"	"	
3654	"	"		3838	"	"	

Vogn nr.	Fabr.	Byggear	Merknad	Vogn nr.	Fabr.	Byggear	Merknad
3839	Str	20		4126	Skb	24	
3840	"	"		4127	"	"	
3841	AaB	23		4128	"	"	
3842	"	"		4129	"	"	
3843	"	"		4130	"	"	
3844	"	"		4131	"	"	
3846	"	"		4132	"	"	
3847	"	"		4133	"	"	
3850	"	"		4194	Atl	76	2) 3)
3891	"	"		5325	HJ	12	
3894	"	"		5327	"	"	
3896	"	"		5328	"	"	
3897	"	"		5330	AaB	14	
3899	"	"		5331	"	"	
3902	Atl	76	1)	5332	"	"	
3904	"	"	1)	5334	"	"	
3908	Oslo	25		5335	"	"	
3910	"	"		5336	"	"	
3911	"	"		5338	"	"	
3918	"	"		5339	"	"	
3960	Atl	76	1)	5340	"	"	
3999	"	"	1)	5341	"	"	
4024	Oslo	25		5342	"	"	
4027	"	"		5343	"	"	
4036	"	"		5344	"	"	
4037	"	"		5345	"	"	
4040	"	"		5346	"	"	
4079	Atl	76	1)	5347	"	"	
4119	Skb	24		5348	"	"	
4120	"	"		5349	Str	20	
4121	"	"		5350	"	"	
4122	"	"		5352	"	"	
4123	"	"		5353	"	"	
4124	"	"		5354	"	"	
4125	"	"		5355	"	"	

1) H-tegn. ukjent. 2) H-tegn. 815. 3) Tank for melktransport.

Vogn nr.	Fabr.	Byggeår	Merknad	Vogn nr.	Fabr.	Byggeår	Merknad
5356	Str	20		5733	Skb	24	
5357	"	"		5734	"	"	
5358	"	"		5735	"	"	
5359	"	"		5736	"	"	
5361	"	"		5737	"	"	
5364	"	"		5738	"	"	
5365	"	"		5739	"	"	
5366	"	"		5741	"	"	
5367	"	"		5742	"	"	
5368	"	"		5743	"	"	
5601	AaB	13		5744	"	"	
5602	"	"		5746	"	"	
5603	"	"		5750	"	"	
5604	"	"		6461	HJ	12	
5605	"	"		6466	"	"	
5606	"	"		6468	"	"	
5607	"	"		6469	"	"	
5608	"	"		6470	"	"	
5609	"	"		6471	"	"	
5610	"	"		6472	"	"	
5611	"	"		6474	"	"	
5613	"	"		6476	"	"	
5615	"	"		6477	Str	"	
5616	"	"		6478	"	"	
5617	"	"		6479	"	"	
5618	"	"		6480	"	"	
5619	"	"		6486	"	"	
5717	Skb	23		6488	"	"	
5719	"	"		6489	"	"	
5721	"	"		6490	"	"	
5722	"	"		6493	"	"	
5724	"	"		6496	"	"	
5726	"	24		6497	"	"	
5728	"	"		6498	"	"	
5730	"	"		6501	"	"	

N2
TYPE 2

Vogn nr.	Fabr.	Byggeår	Merknad	Vogn nr.	Fabr.	Byggeår	Merknad
6507	Str	12		6683	Skb	16	
6508	"	"		6685	"	"	
6509	"	"		6686	"	"	
6510	"	"		6687	"	"	
6511	"	"		6688	"	"	
6514	"	"		6689	"	"	
6516	"	"		6690	"	"	
6517	"	"		6691	"	"	
6520	"	"		6693	"	"	
6522	"	"		6694	"	"	
6523	"	"		6696	"	"	
6524	"	"		6697	"	"	
6525	"	"		6698	"	"	
6526	"	"		6700	"	"	
6528	"	"		6952	Str	20	
6529	"	"		6955	"	"	
6530	"	"		6956	"	"	
6531	"	"		6958	"	"	
6532	"	"		6960	"	"	
6535	"	"		6961	"	"	
6662	Skb	16		6962	"	"	
6663	"	"		6963	"	"	
6667	"	"		6964	"	"	
6668	"	"		6966	"	"	
6669	"	"		6968	"	"	
6670	"	"		6970	"	"	
6671	"	"		6971	"	"	
6674	"	"		8626	Skb	23	
6676	"	"		8627	"	"	
6677	"	"		8628	"	"	
6678	"	"		8629	"	"	
6679	"	"		8630	"	"	
6680	"	"		8631	"	"	
6681	"	"		8633	"	"	
6682	"	"		8635	"	"	
				8636	"	"	

Vogn nr.	Fabr.	Byggeår	Merknad	Vogn nr.	Fabr.	Byggeår	Merknad
8638	Skb	23		9569	Str	17	
8639	"	"		9570	"	"	
8640	"	"		9572	"	"	
8643	"	"		9574	"	"	
8646	"	"		9575	"	"	
8648	"	"		9576	"	"	
8649	"	"		9578	"	"	
8674	"	24		9579	"	"	
8675	"	"		9580	"	"	
8676	"	"		9581	"	"	
8678	"	"		9582	"	"	
8679	"	"	4)	9583	"	"	
8680	"	"		9585	"	"	
9537	"	16		9586	"	"	
9538	"	"		9587	"	"	
9544	"	"		9588	"	"	
9545	"	"		9589	"	"	
9546	"	"		9591	"	"	
9548	"	"		9592	"	"	
9549	"	"		9595	"	"	
9550	"	"		9596	"	"	
9551	"	"		9598	"	"	
9552	"	"		9600	"	"	
9553	"	"		9601	"	"	
9554	"	"		9602	"	"	
9555	"	"		9603	"	"	
9556	"	"		9604	"	"	
9558	"	"		9605	"	"	
9559	"	"		9608	"	"	
9560	"	"		9609	"	"	
9561	"	"		9610	"	"	
9562	"	"		9612	"	"	
9563	"	"		9613	"	"	
9566	"	"		9614	"	"	
9568	Str	17		9615	"	"	

4) Har skruebremse.

N2
TYPE 2

Vogn nr.	Fabr.	Byggeår	Merknad	Vogn nr.	Fabr.	Byggeår	Merknad
9616	Str	17		16376	Str	20	
9618	"	"		16377	"	"	
9619	"	"		16378	"	"	
9620	"	"		16380	"	"	
9621	"	"		16381	"	"	
9622	"	"		16382	"	"	
9623	"	"		16383	"	"	
9625	"	"		16384	"	"	
14470	HJ	14		16385	AaB	23	
14471	"	"		16386	"	"	
14472	"	"		16387	"	"	
14473	"	"		16388	"	"	
14475	"	"		16389	"	"	
14476	"	"		16390	"	"	
14477	"	"		16391	"	"	
14481	"	"		16392	"	"	
14482	"	"		16393	"	"	
14483	"	"		16394	"	"	
14486	"	"		16395	"	"	
14487	"	"		16396	"	"	
14488	"	"		16397	"	"	
14490	"	"		16401	"	"	
14491	"	"		16403	"	"	
14492	"	"		16404	"	"	
14493	"	"		16405	"	"	
14494	"	"		16407	"	"	
14495	"	"		16408	"	"	
14498	"	"		16409	"	"	
16365	Str	20		16410	"	"	
16366	"	"		16411	"	"	
16368	"	"		16413	"	"	
16369	"	"		16414	"	"	
16371	"	"		16415	Edf	24	
16372	"	"		16416	"	"	
16373	"	"		16417	"	"	

Vogn nr.	Fabr.	Byggear	Merknad	Vogn nr.	Fabr.	Byggear	Merknad
16418	Edf	24		20101	AaB	21	
16419	"	"		20103	"	"	
16420	"	"		20105	"	"	
16422	"	"		20106	"	"	
16424	"	"		20107	"	"	
16426	"	"		20108	"	"	
16427	"	"		20109	"	"	
16429	"	"		20110	"	"	
16432	"	"		20111	"	"	
16434	"	"		20112	"	"	
16435	"	"		20113	"	"	
16436	"	"		20114	"	"	
16437	"	"		20115	"	"	
16438	"	"		20116	"	"	
16441	"	"		20117	"	"	
16442	"	"		20118	"	"	
16443	"	"		20119	"	"	
16465	Skb	"		20120	"	"	
16466	"	"		20121	"	"	
16467	"	"		20122	"	"	
16468	"	"		20123	"	"	
16469	"	"		20124	"	"	
16470	"	"		20125	"	"	
16471	"	"		20126	"	22	
16472	"	"		20127	"	"	
16473	"	"		20128	"	"	
16474	"	"		20129	"	"	
16555	Str	20		20131	"	"	
16556	"	"		20132	"	"	
16557	"	"		20133	"	"	
16558	"	"		20134	"	"	
16560	"	"		20136	"	"	
16561	"	"		20137	"	"	
16562	"	"		20138	"	"	
16563	"	"		20139	"	"	

Vogn nr.	Fabr.	Byggear	Merknad	Vogn nr.	Fabr.	Byggear	Merknad
20140	AaB	22		20230	AaB	22	
20141	"	"		20702	"	13	
20142	"	"		20703	"	"	
20143	"	"		20704	"	"	
20145	"	"		20706	"	"	
20146	"	"		20707	"	"	
20147	"	"		20709	"	"	
20149	"	"		20710	"	"	
20150	"	"		20711	"	"	
20201	"	"		20712	"	"	
20202	"	"		20713	"	"	
20203	"	"		20714	"	"	
20204	"	"		20715	"	"	
20205	"	"		20716	"	"	
20207	"	"		20719	"	"	
20208	"	"		20721	"	"	
20209	"	"		20722	"	"	
20210	"	"		20723	"	"	
20211	"	"		20725	"	"	
20212	"	"		20726	"	"	
20213	"	"		20727	"	"	
20214	"	"		20730	"	"	
20215	"	"		20731	"	"	
20216	"	"		20733	"	"	
20217	"	"		20734	"	"	
20218	"	"		20735	"	"	
20219	"	"		20736	"	"	
20220	"	"		20737	"	"	
20221	"	"		20739	"	"	
20222	"	"		20740	"	"	
20223	"	"		23001	"	14	
20224	"	"		23002	"	"	
20226	"	"		23003	"	"	
20227	"	"		23005	"	"	
20229	"	"		23006	"	"	

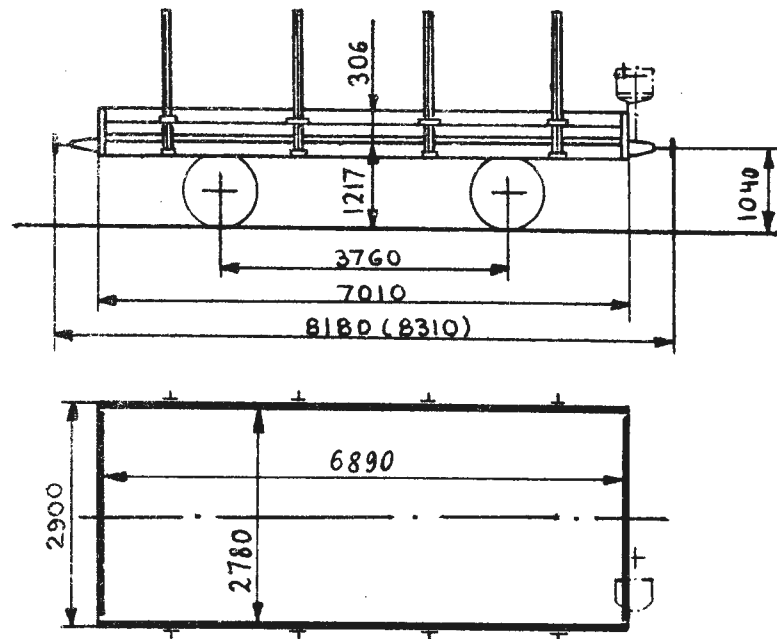

Bæreevne

A	B	C
11,5t	11,5t	

Omtrentlig vognvekt 6,0-6,5 t
 Gulvflate 19,1 m²
 Rominnhold 5,8 m³
 Hovedtegning 3070 1)

STAKEVOGN

Vogn nr.	Fabr.	Byggeår	Merknad	Vogn nr.	Fabr.	Byggeår	Merknad
2441	Str	99		3919	Oslo	16	
2579	Skb	89		3937	"	14	
2604	Str	91		3950	"	16	
2606	"	"		3954	"	14	
2629	"	97		3962	Atl	76	
2639	"	"		3985	"	77	
2646	"	"		4000	Oslo	13	
2676	"	98		4001	"	14	
2678	"	"		4005	"	19	
2773	MMV	99		4011	"	15	
2866	Skb	00		4022	"	14	
2882	"	"		4031	Atl	16	
2887	"	"		5276	Str	00	
3907	Oslo	15		5279	"	"	
3909	"	16		5289	"	"	

1) Vogner med litra N2-3 er vogner med tidl. litra N1-1, som er ombygd etter tegn. 3070.

Vogn nr.	Fabr.	Byggeår	Merknad	Vogn nr.	Fabr.	Byggeår	Merknad
5292	Str	00		10838	Str	01	
5296	"	"		10999	AaB	12	
5302	"	"		12502	Str	00	
5303	"	"		12503	"	"	
6327	"	97		12509	"	"	
6380	Skb	00		12520	"	"	
6390	"	"		12521	"	"	
7507	Str	92		12535	"	"	
7512	"	"		16048	"	99	
7525	"	"		16076	"	"	
7531	"	"		16092	KvB	93	
8504	"	"		16106	Edf	00	
8528	Ldv	92		16132	"	"	
8530	"	"		16140	"	"	
8558	"	95		16165	"	"	
8560	"	"		16175	"	"	
8572	Str	97		16190	"	01	
8574	"	"		16195	"	"	
8601	"	99		16206	"	"	
8608	"	"		16210	"	"	
8615	"	"		16213	"	"	
8656	HJ	14		16228	"	"	
8657	"	"		16231	"	"	2)
8659	"	"		16232	"	"	
8668	"	"		16259	"	"	
8669	"	"		16263	"	06	
8670	"	"		16266	"	"	
9511	Edf	00		16284	"	"	
9516	Skb	"		16294	"	"	
9524	"	"		16306	Skb	08	
10804	"	"		16307	"	"	
10807	"	"		16308	"	"	
10811	"	"		16310	"	"	
10814	"	"		16445	AaB	12	
10823	"	"		16454	"	"	

2) Påmontert melktank for Drm. meieri.

Vogn nr.	Fabr.	Byggeår	Merknad	Vogn nr.	Fabr.	Byggeår	Merknad
16458	AaB	12					
16460	"	"					
16462	"	"					

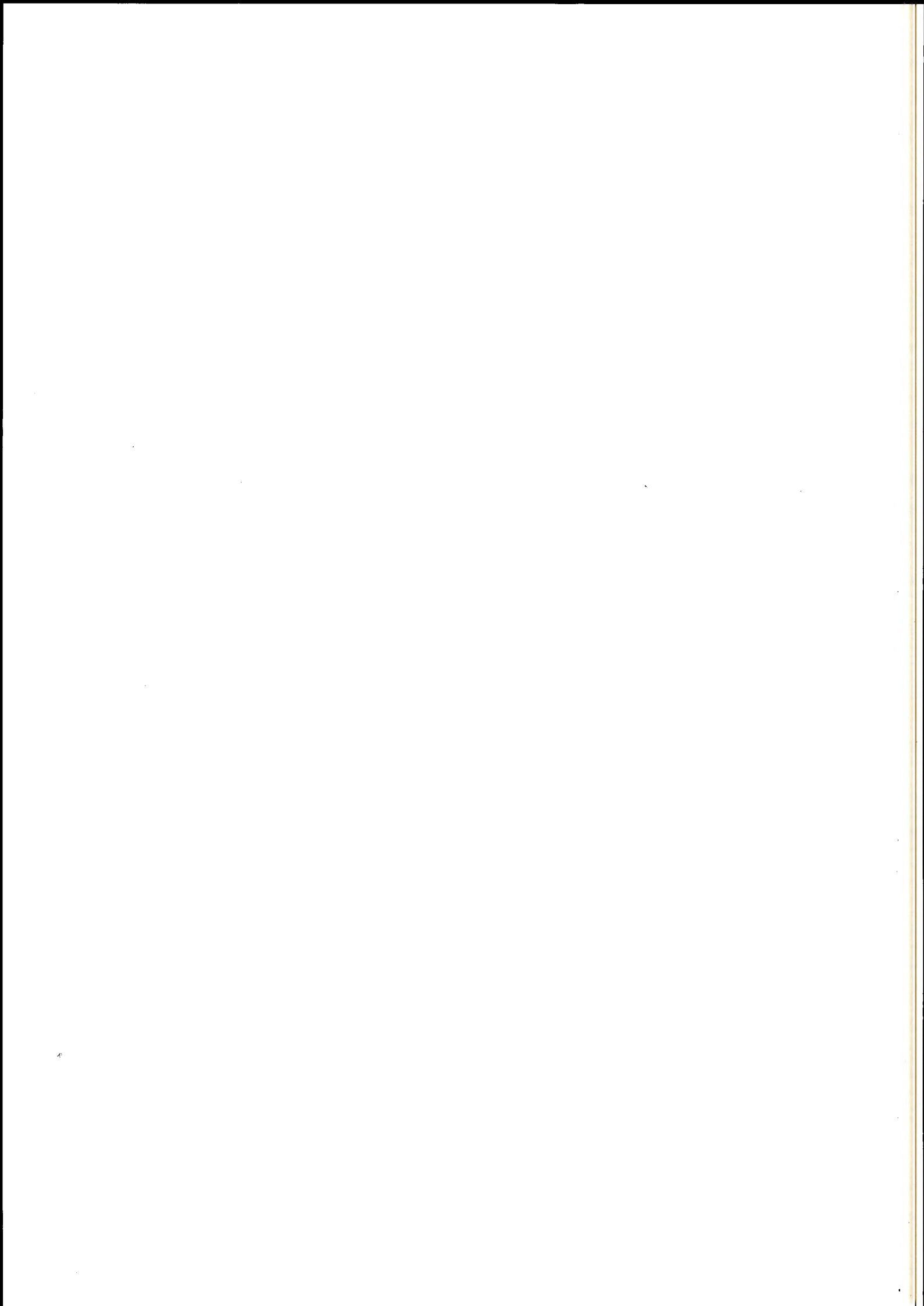

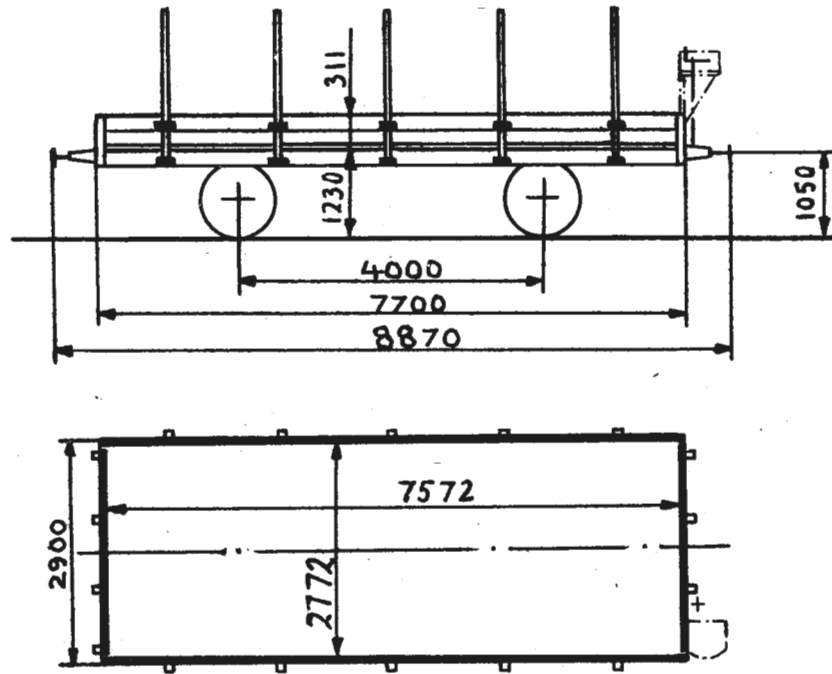

Omtrentlig egenvekt	7,5	t.
" last	15,5	t.
Gulvflate	21,0	m ²
Rominnhold	6,5	m
Hovedtegning	617	

STAKEVOGN

Vogn nr.	Fabr.	Byggeår	Merknad	Vogn nr.	Fabr.	Byggeår	Merknad
13005	Skb	02					
13006	"	"					
13007	"	"					
13008	Str	"					
13009	"	"					
13010	"	"					
13024	Skb	05					
13025	"	"					
13026	"	"					
13028	"	"					
13029	"	"					
13030	"	"					
13031	"	"					
13032	"	"					
13096	x)	15					

x) Bygget i Narvik

No1

TYPE 1

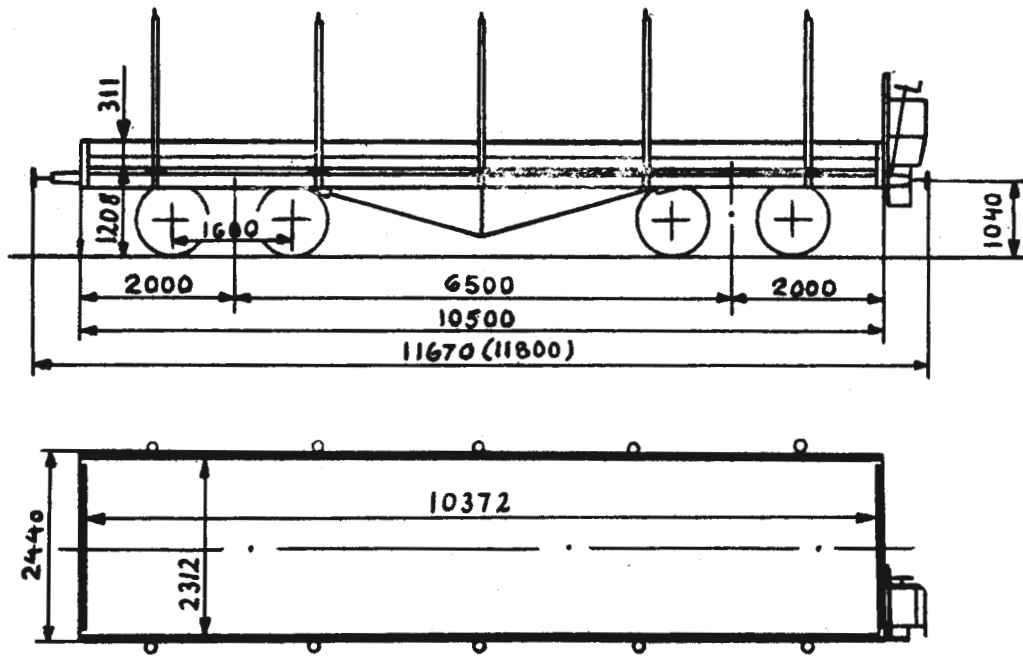

Omtrentlig vognvekt	11,0 t
" last	22,5 t
Gulvflate	23,1 m ²
Rominnhold	7,2 m ³
Hovedtegning	408 1)

STAKEVOGN

Vogn nr.	Fabr.	Byggeår	Merknad	Vogn nr.	Fabr.	Byggeår	Merknad
6853	H&R	99					
6857	"	"					
15992	Skb	09					

1) Bremsarhuset er fjernet og erstattet med bremsplattform etter tegn. 3788.

Nfo2

TYPE 1

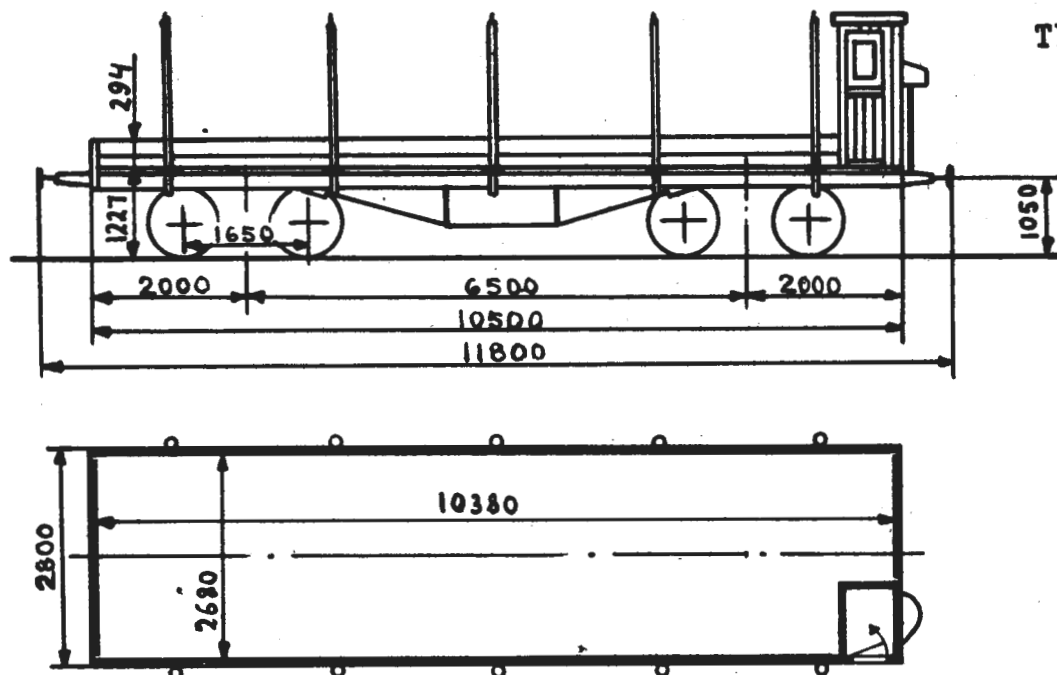

Bæreevne

A	B	C
23,5t	23,5t	

Omtrentlig vognvekt 12,0 t
 Gulvflate 26,9 m²
 Rominnhold 7,9 m³
 Hovedtegning 2171

STAKEVOGN

Vogn nr.	Fabr.	Byggeår	Merknad	Vogn nr.	Fabr.	Byggeår	Merknad
10938	Str	22					

NP2

TYPE 1

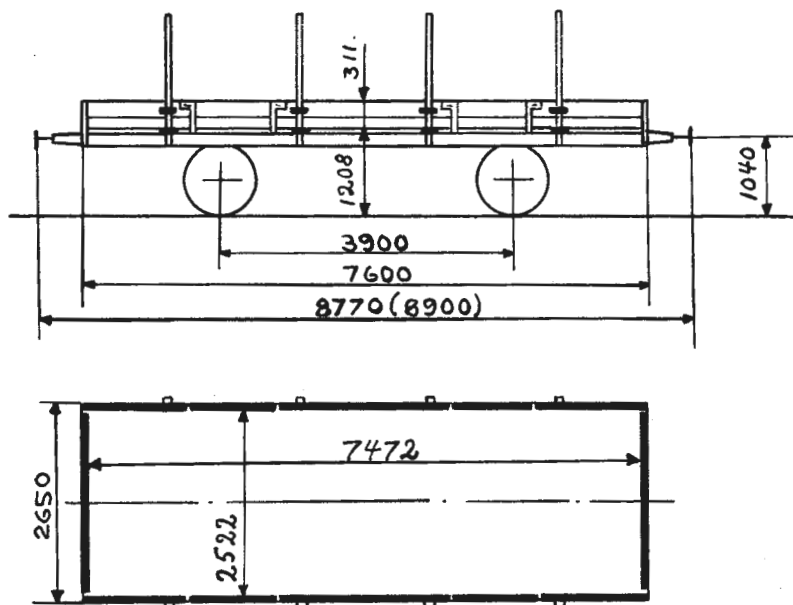

Omtrentlig vognvekt 6,0-7,0 t
 " last 11,0 t
 Gulvflate 18,9 m²
 Rominnhold 5,9 m³
 Hovedtegning 815+897 eller
 815+897+4363

STAKE- OG MALMVOGN

Vogn nr.	Fabr.	Byggeår	Merknad	Vogn nr.	Fabr.	Byggeår	Merknad
			H-tegn. 815+897	16317	AaB	09	
5309	Str	09		16321	"	"	
5310	"	"		16323	"	"	
5317	"	"		16324	"	"	
10101	"	08		16326	"	"	
10505	"	"		16334	"	"	
10506	"	"		16337	"	"	
10513	"	05		16339	"	"	
10517	"	"		16342	"	"	
10519	"	"		16344	"	"	
10524	"	"		16347	Str	"	
			H-tegn. 815+897+ 4363	16350	"	"	
16313	AaB	09		16353	"	"	
16316	"	"		16359	"	"	
				16361	"	"	
				16363	"	"	

NP3

TYPE 1

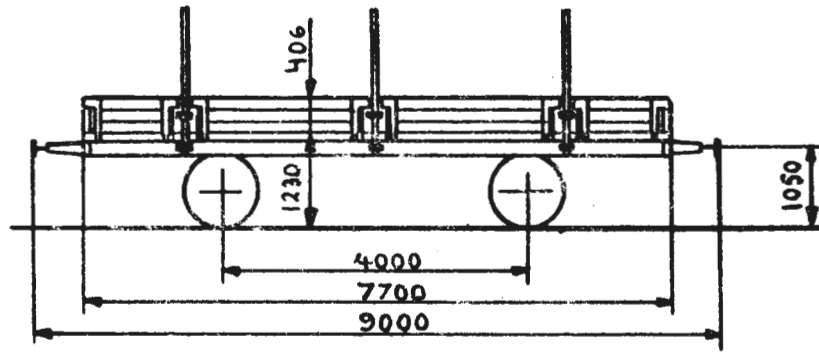

Omtrentlig vognvekt 8,0 t
 " last 15,0 t
 Gulvflate 21,2 m²
 Rominnhold 8,6 m³
 Hovedtegning 1268

STAKE- OG MALMVOGN

Vogn nr.	Fabr.	Byggeår	Merknad	Vogn nr.	Fabr.	Byggeår	Merknad
13054	Edf	11		13072	Edf	15	
13055	"	"		13073	"	"	
13056	"	"		13086	AaB	23	
13057	"	"		13087	"	"	
13059	"	"		13088	"	"	
13060	"	"		13089	"	"	
13061	"	"		13090	"	"	
13063	"	"		13091	"	"	
13064	"	15		13092	"	"	
13065	"	"		13093	"	"	
13066	"	"		13094	"	"	
13067	"	"		13095	"	"	
13068	"	"					
13069	"	"					
13071	"	"					

Vogner med litra NP3-1 har nedleggbare lemmer.

NPo3

TYPE 1

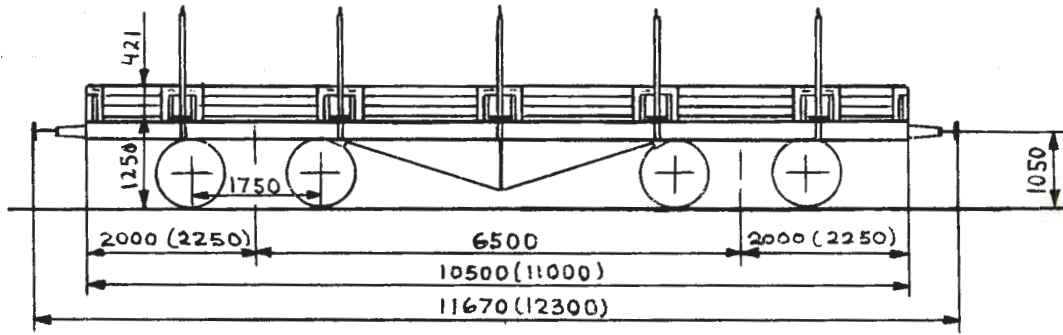

Måli() for vogner nr. 13080, 13081.

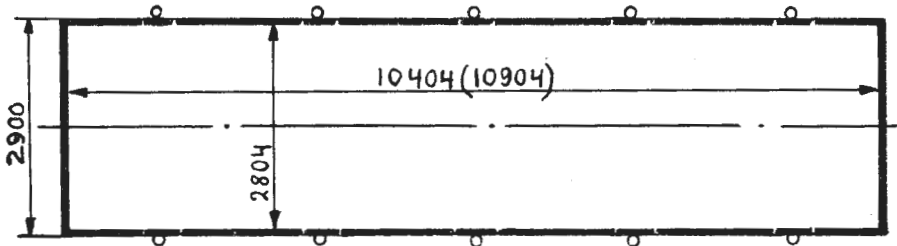

Omtrentlig vognvekt 14,0-15,0 t
 " last 31,0-32,0 t
 Gulvflate 29,1-30,6 m²
 Rominnhold 12,2-12,8 m³
 Hovedtegning 917

STAKE- OG MALMVOGN

Vogn nr.	Fabr.	Byggeår	Merknad	Vogn nr.	Fabr.	Byggeår	Merknad
13042	Edf	09	2)				
13043	"	"					
13080	Skb	21	1) 3)				
13081	"	"	1)				

1) Forøket lengde. 2) Vognvekt 15670 kg, inklusive 1 kran. 3) Vognvekt 16180 kg, inklusive 1 kran.

Trykk nr. 752 1.1.61

Vogn nr.	Fabr.	Byggeår	Merknad	Vogn nr.	Fabr.	Byggeår	Merknad
6550	Skb	14		6585	Skb	14	1)
6551	"	"	1)	6586	"	"	1)
6552	"	"	1)	6587	"	"	1)
6553	"	"		6588	"	"	1)
6554	"	"		6589	"	"	1)
6555	"	"		6591	"	"	1)
6556	"	"		6592	"	"	
6557	"	"		6593	"	"	
6558	"	"		6594	"	"	1)
6559	"	"	1)	6595	"	"	1)
6560	"	"		6596	"	"	
6561	"	"		6597	"	"	
6562	"	"		6598	"	"	
6563	"	"	1)	6599	"	"	1)
6564	"	"		6600	"	"	
6565	"	"		6601	"	"	1)
6566	"	"	1)	6602	"	"	1)
6567	"	"		6603	"	"	1)
6568	"	"		6604	"	"	
6569	"	"	1)	6605	"	"	
6570	"	"		6606	"	"	
6571	"	"	1)	6607	"	"	
6572	"	"	1)	6608	"	"	
6573	"	"	1)	6609	"	"	1)
6574	"	"	1)	6610	"	"	
6575	"	"	1)	6611	Str	14	
6576	"	"		6612	"	"	
6577	"	"	1)	6613	"	"	1)
6578	"	"	1)	6614	"	"	1)
6579	"	"	1)	6615	"	"	
6580	"	"		6616	"	"	
6581	"	"	1)	6617	"	"	
6582	"	"		6618	"	"	
6583	"	"	1)	6619	"	"	1) 2)
6584	"	"		6620	"	"	

1) Höye endelemmer. 2) Har monteret tank for transport av levende fisk.

Vogn nr.	Fabr.	Byggear	Merknad	Vogn nr.	Fabr.	Byggear	Merknad
6621	Str	14		11936	Str	16	
6622	"	"		11937	"	"	
6623	"	"		11938	"	"	1)
6624	"	"	1)	11939	"	"	
6626	"	"	1)	11940	"	"	1)
6627	"	"		11941	"	"	1)
6629	"	"		11942	"	"	1)
6630	"	"		11943	"	"	
6631	"	"	1)	11944	"	"	1)
6632	"	"		11945	"	"	
6633	"	"	1)	14499	"	14	1)
6634	"	"		14500	"	"	1)
6636	"	"		14501	"	"	
6637	"	"	1)	14502	"	"	1)
6638	"	"	1)	14503	"	"	1)
6639	"	"		14504	"	"	
6640	"	"		14505	"	"	1)
6641	"	"		14506	"	"	1)
6642	"	"		14507	"	"	1)
6643	"	"		14508	"	"	1)
6644	"	"		14509	"	"	1)
6645	"	"		14511	"	"	
6646	"	"	1)	14512	"	"	
6649	"	"	1)	14513	"	"	1)
6650	"	"	1)	14514	"	"	1)
6651	"	"	1)	14515	"	"	1)
6652	"	"	1)	14516	"	"	1)
6653	"	"	1)	14517	"	"	
6654	"	"		14518	"	"	
6655	"	"		14519	"	"	1)
6656	"	"		14520	"	"	1)
6657	"	"		14521	"	"	
6658	"	"		14522	"	"	
6659	"	"	1)	14524	"	"	1)
6660	"	"		14525	"	"	1)

1) Höye endelemmer.

Vogn nr.	Fabr.	Byggear	Merknad	Vogn nr.	Fabr.	Byggear	Merknad
14526	Str	14	1)	17099	LH	21	1)
14527	"	"		17100	"	"	1)
14528	"	"		17101	"	"	
17001	"	"	1)	17102	"	"	3)
17002	"	"		17103	"	"	1)
17003	"	"		17104	"	"	1)
17004	"	"	1)	17105	"	"	1)
17005	"	"	1)	17106	"	"	1)
17006	"	"	1)	17107	"	"	1)
17007	"	"	1)	17108	"	"	1)
17008	"	"	1)	17109	"	"	
17009	"	"		17110	"	"	1)
17010	"	"	1)	17111	"	"	1)
17011	"	"	1)	17112	"	"	
17012	"	"	1)	17113	"	"	1)
17013	"	"		17114	"	"	1)
17014	"	"	1)	17115	"	"	1)
17015	"	"		17116	"	"	1)
17016	"	"	1)	17117	"	"	
17017	"	"		17118	"	"	
17018	"	"		17119	"	"	
17019	"	"		17120	"	"	
17020	"	"	1)	17121	"	"	
17021	"	"		17122	"	"	1)
17022	"	"	1)	17123	"	"	
17023	"	"	1)	17124	"	"	1)
17024	"	"		17125	"	"	1)
17025	"	"		17126	"	"	
17091	LH	21	1)	17127	"	"	
17092	"	"	1)	17128	"	"	
17093	"	"	1)	17129	"	"	1)
17094	"	"		17130	"	"	1)
17095	"	"	1)	17131	"	"	
17096	"	"	1)	17132	"	"	1)
17097	"	"	1)	17133	"	"	
17098	"	"	1)				

1) Høye endelemmer. 3) Påmont. ploganordning for nedlegging av kabel.

T3
TYPE 1

Vogn nr.	Fabr.	Byggeår	Merknad	Vogn nr.	Fabr.	Byggeår	Merknad
17134	LH	21					
17135	"	"	1)				
17551	Skb	22	1)				
17552	"	"	1)				
17553	"	"					
17554	"	"	1)				
17555	"	"					
17556	"	"					
17558	"	"	1)				
17559	"	"	1)				
17560	"	"	1)				
17561	"	"					
17562	"	"	1)				
17563	"	"					
17564	"	"	1)				

1) Høye endelemmer.

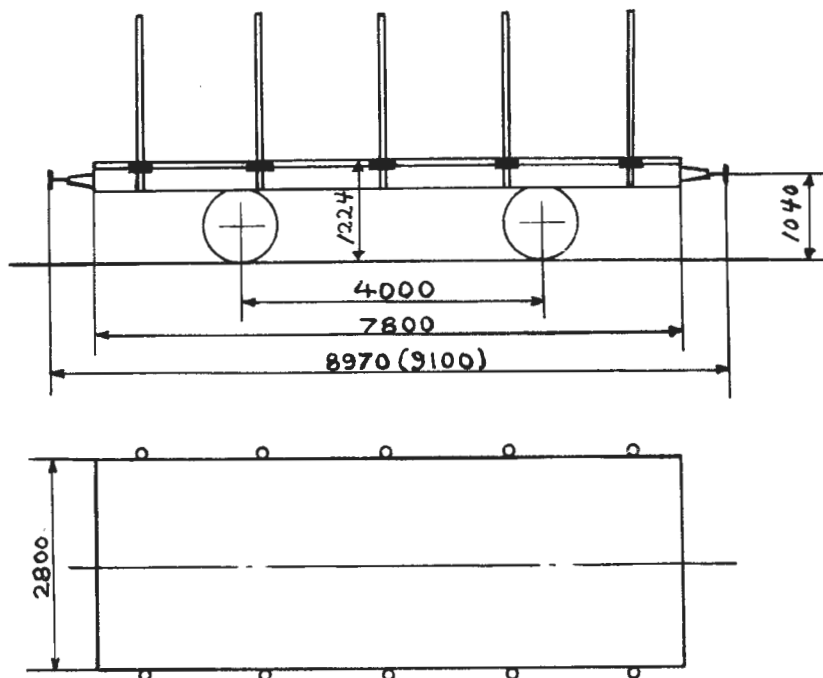

Bæreevne

A	B	C
17,0t	17,0t	

Omtrentlig vognvekt 6,0-7,0 t
 Gulvflate 21,8 m²
 Rominnhold -
 Hovedtegning Ukjent
 (Antakelig o.d. tegn. B 195)

PLATTFORMVOGN

Vogn nr.	Fabr.	Byggeår	Merknad	Vogn nr.	Fabr.	Byggeår	Merknad
11901	AaB	08		11933	Str	10	
11902	"	"		11935	"	"	1)
11906	"	"					
11908	"	"					
11909	"	"					
11912	"	"					
11918	"	"					
11919	"	"					
11921	Str	10					
11922	"	"					
11923	"	"					
11925	"	"					
11926	"	"					
11929	"	"					
11930	"	"					

1) Har montert provisorisk tank.

T3
TYPE 3

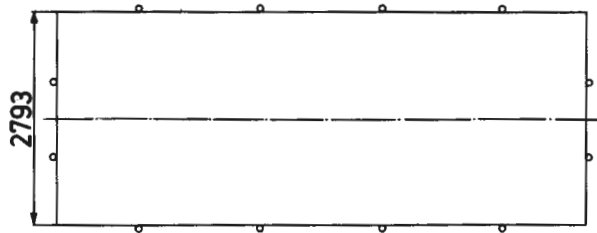
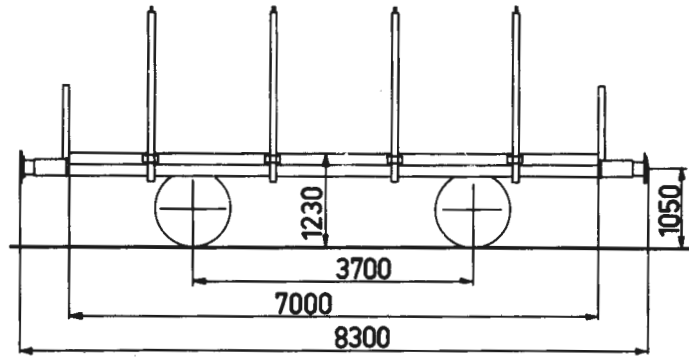

Bæreevne

A	B	C
17,5 t	17,5 t	

Omtrentlig vognvekt 6,5t

Gulvflate 19,1 m²

Rominhold -

Hovedtegning Skabo H-71)

PLATTFORMVOGN

Vogn nr.	Fabr.	Byggear	Merknad	Vogn nr.	Fabr.	Byggear	Merknad
23434	Skb	13					

1) Forandret etter Hd. M. skisse dat. 29.4. 58
Trykk nr. 752 1.1. 59

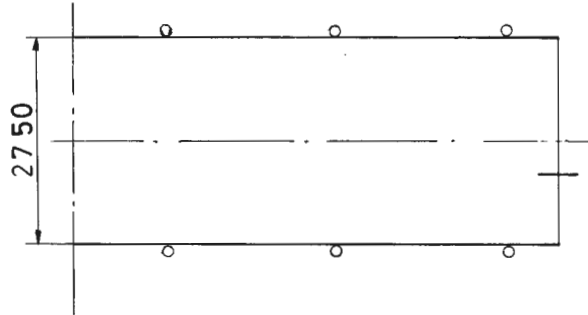
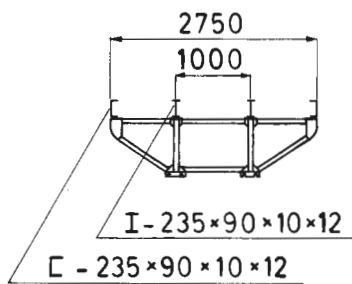
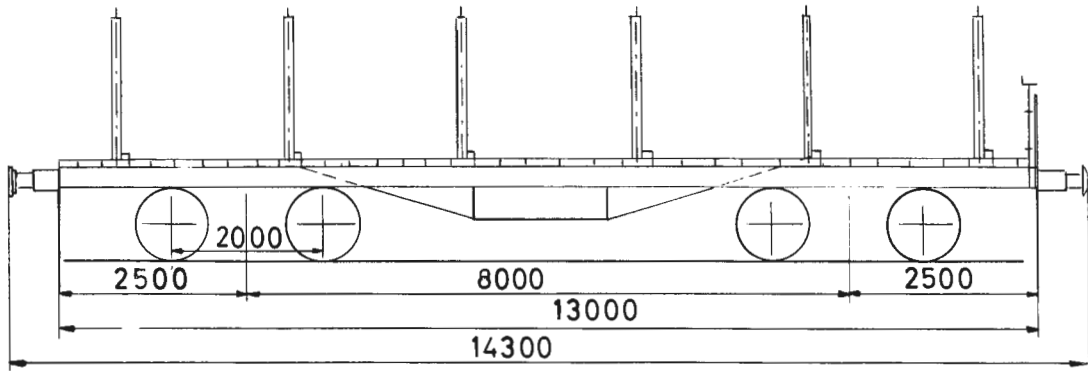

Omtrentlig vognvekt 16,0t

Hovedtegning 13955

Bæreevne

Jevnt fordelt last

A	B	C
37,0t		37,0t

Konsentrerte belastninger

	m	t
a-a	0,5	16,0
b-b	6,0	19,0
c-c	8,0	23,0
d-d	10,5	37,0

PLATTFORMVOGN

Vogn nr.	Fabr.	Byggeår	Merknad	Vogn nr.	Fabr.	Byggeår	Merknad
38211	-	-					

To
TYPE 3

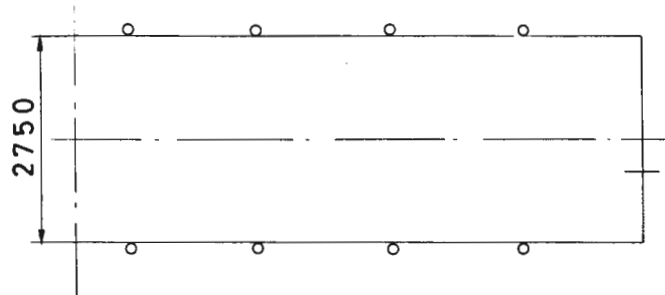
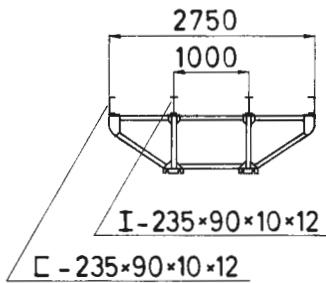
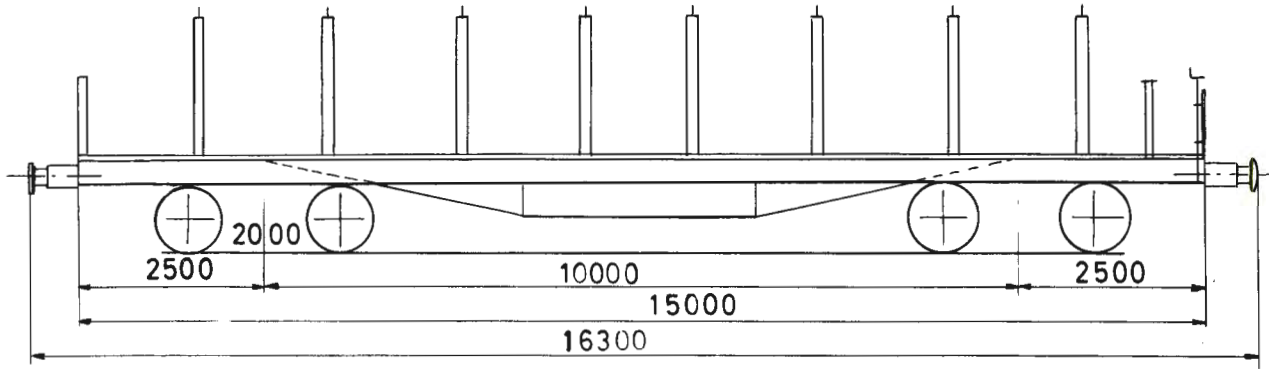

Omtrentlig vognvekt 18,0-20,5 t

Hovedtegning 13956

Bæreevne

Jevnt fordelt last

A	B	C
37,0t		37,0t

Konsentrerte belastninger

	m	t
a-a	0,5	12,0
b-b	2,0	15,0
c-c	9,5	22,0
d-d	11,0	27,0
e-e	12,5	37,0

PLATTFORMVOGN

Vogn nr.	Fabr.	Byggeår	Merknad	Vogn nr.	Fabr.	Byggeår	Merknad
38212	-	-	Vegg ved bremsepl.f. fjernet				
38218	-	-					
38226	-	-					

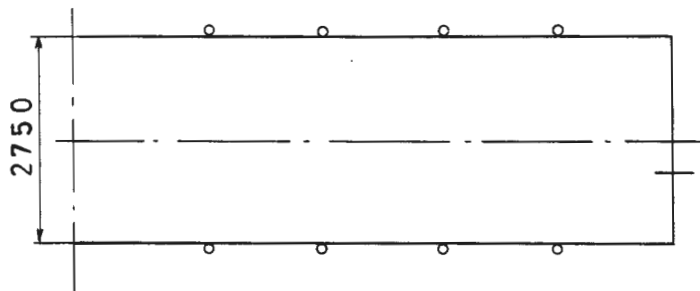
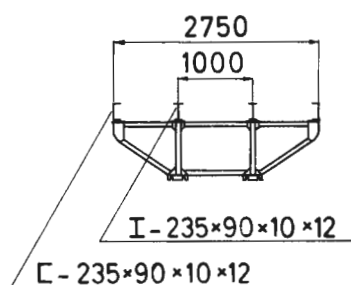
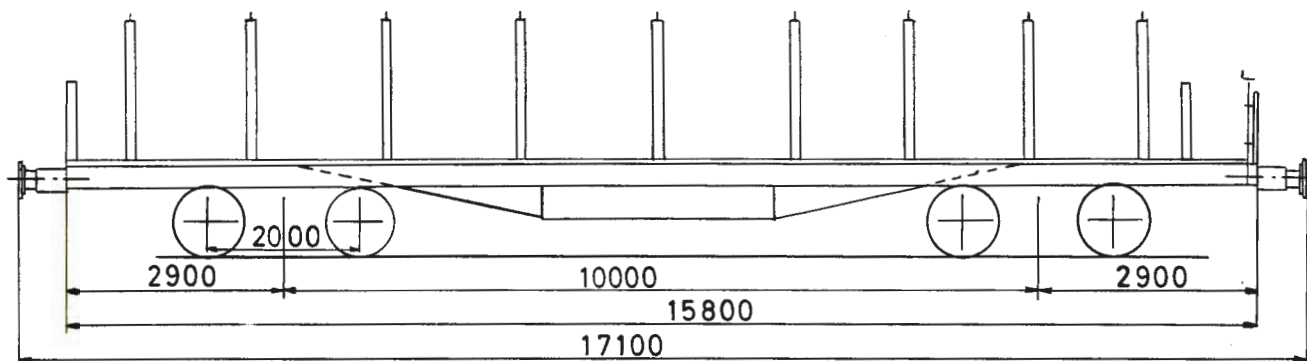

Omtrentlig vognvekt 18,5 t

Hovedtegning 13957

Bæreevne

Jevnt fordelt last

A	B	C
37,0t	37,0t	

Konsentrerte belastninger

	m	t
a-a	0,5	14,0
b-b	2,0	18,0
c-c	8,0	22,0
d-d	10,5	27,0
e-e	12,5	37,0

PLATTFORMVOGN

Vogn nr.	Fabr.	Byggeår	Merknad	Vogn nr.	Fabr.	Byggeår	Merknad
38213	MAN	14					
38244	"	"	Vegg ved bremsepl.f. fjernet				

To
TYPE 5 J

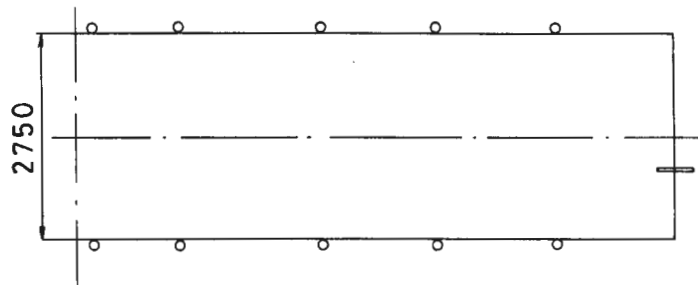
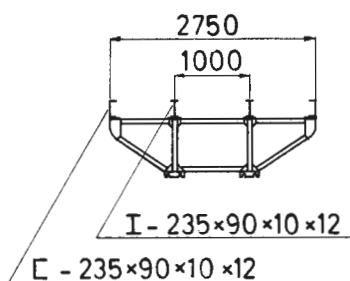
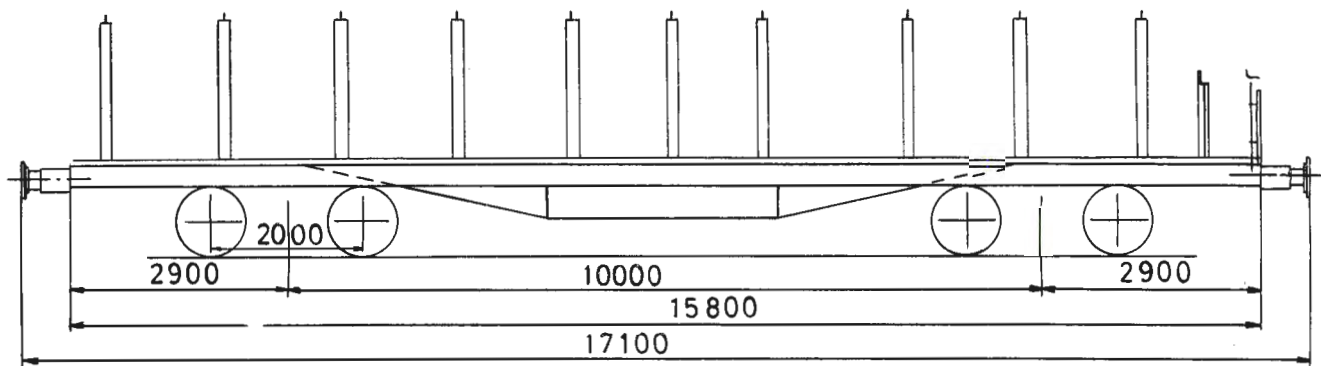

Omtrentlig vognvekt 18,5-20,5t

Hovedtegning 13958

Bæreevne

Jevnt fordelt last

A	B	C
37,0t		37,0t

Konsentrerte belastninger

	m	t
a - a	0,5	15,0
b - b	3,0	22,0
c - c	8,0	23,0
d - d	10,5	27,0
e - e	12,5	37,0

PLATTFORMVOGN

Vogn nr.	Fabr.	Byggeår	Merknad	Vogn nr.	Fabr.	Byggeår	Merknad
38207	-	-					
38214	RMM	21					
38220	MAN	10					
38221	-	-					
38222	-	-					
38228	-	-					
38248	-	-					

To1

TYPE 1

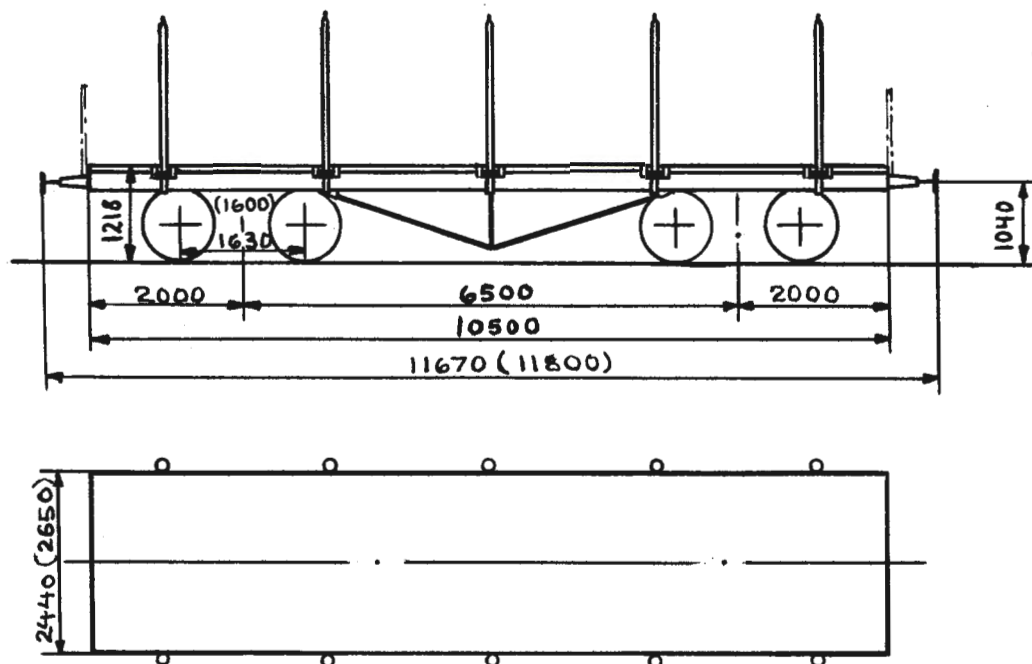

Omtrentlig vognvekt	10,0 t
" last	23,5 t
Gulvflate	25,6-27,8 m ²
Rominhold	-
Hovedtegning	768

PLATTFORMVOGN

Vogn nr.	Fabr.	Byggeår	Merknad	Vogn nr.	Fabr.	Byggeår	Merknad
14901	Skb	04					
14903	Edf	05					
14910	Str	22					
15997	Skb	"					

To3
TYPE 1

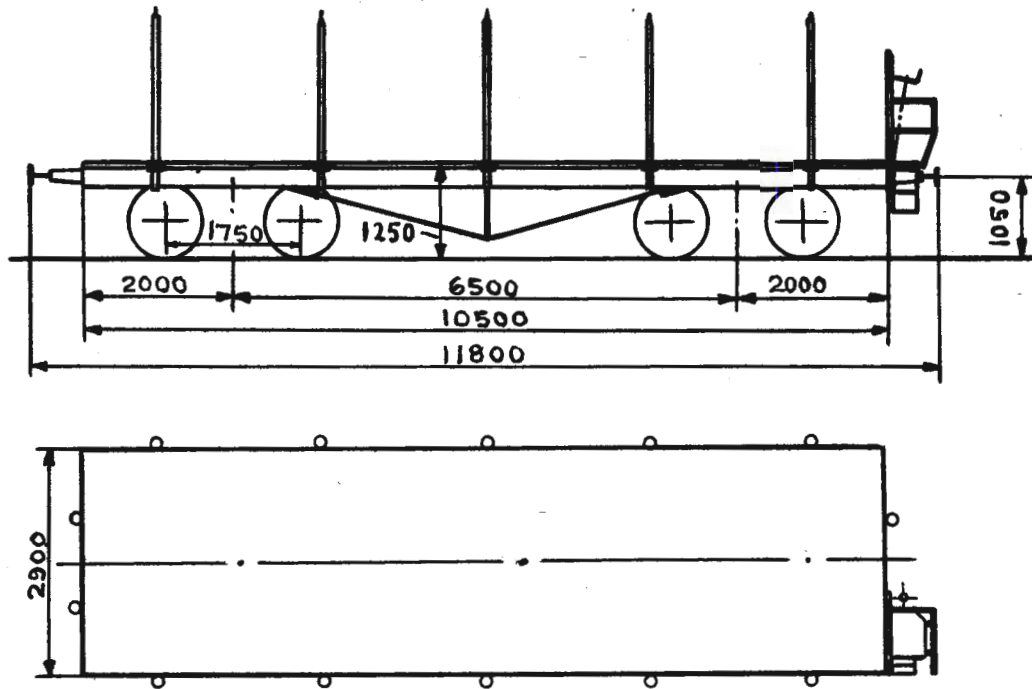

Omtrentlig egenvekt 13,8 t.
 " last 32,0 t.
 Gulvflate 30,5 m²
 Rominnhold -

1) Hovedtegning Opprinnelig 2157

PLATTFORMVOGN

Vogn nr.	Fabr.	Byggeår	Merknad	Vogn nr.	Fabr.	Byggeår	Merknad
6841	Skb	16					
6842	"	"					
6843	"	"					
6844	"	"					
6845	"	"					

1) Vognene er ombygd fra NPfo-vogner.

Vogn nr.	Fabr.	Byggear	Merknad	Vogn nr.	Fabr.	Byggear	Merknad
5470	Str	27		6226	Str	20	
5471	"	"		6227	"	"	
5472	"	"		6228	"	"	
5473	"	"		6229	"	"	
5474	"	"		6230	"	"	
5751	Edf	25		6231	"	"	
5752	"	"		6232	"	"	
5753	"	"		6233	"	"	
5754	"	"		6234	"	"	
5755	"	"		6235	"	"	
5756	"	"		6236	"	"	
5757	"	"		6237	"	"	
5758	"	"		6238	"	"	
5759	"	"		6239	"	"	
5760	"	"		6240	"	"	
5761	"	"		6241	"	"	
5762	"	"		6242	"	"	
5763	"	"		6243	"	"	
5764	"	"		6244	"	"	
5765	"	"		6245	"	"	
6211	Str	20		6246	"	"	
6212	"	"		6247	"	"	
6213	"	"		6248	"	"	
6214	"	"		6249	"	"	
6215	"	"		6250	"	"	
6216	"	"		6781	Skb	19	
6217	"	"		6782	"	"	
6218	"	"		6783	"	"	
6219	"	"		6784	"	"	
6220	"	"		6785	"	"	
6221	"	"		6786	"	"	
6222	"	"		6787	"	"	
6223	"	"		6788	"	"	
6224	"	"		6789	"	"	
6225	"	"		6790	"	"	

Vogn nr.	Fabr.	Byggear	Merknad	Vogn nr.	Fabr.	Byggear	Merknad
6791	Skb	19		6870	FMV	23	
6792	"	"		6871	"	"	
6793	"	"		6872	"	"	
6794	"	"		6873	"	"	
6795	"	"		6874	"	"	
6796	"	"		6875	"	"	
6797	"	"		6876	"	"	
6798	"	"		6877	"	"	
6799	"	"		6878	"	"	
6800	"	"		6879	"	"	
6821	"	"		6880	"	24	
6822	"	"		6881	"	"	
6823	"	"		6882	"	"	
6824	"	"		6883	"	"	
6825	"	"		6884	"	"	
			H-tegn. 1458 + 2278	6885	"	"	
6826	FMV	23		6886	"	"	
6827	"	"		6887	"	"	
6828	"	"		6888	"	"	
6829	"	"		6889	"	"	
6830	"	"		6890	"	"	
6831	"	"		6891	"	"	
6832	"	"		6892	"	"	
6833	"	"		6893	"	"	
6834	"	"		6894	"	"	
6835	"	"		6895	"	"	
6836	"	"		6896	"	"	
6837	"	"		6897	"	"	
6838	"	"		6898	"	"	
6839	"	"		6899	"	"	
6840	"	"		6900	"	"	
6865	"	"		6997	"	"	
6866	"	"		6998	"	"	
6867	"	"		6999	"	"	
6868	"	"		7000	"	"	
6869	"	"					

Vogn nr.	Fabr.	Byggeår	Merknad	Vogn nr.	Fabr.	Byggeår	Merknad
			H-tegn. 1458 + 2140	10475	Skb	19	
10441	Str	16		10476	"	"	
10442	"	"		10477	"	"	
10443	"	"		10478	"	"	
10444	"	"		10479	"	"	
10445	"	"		10480	"	"	
10446	"	"		10481	"	"	
10447	"	"		10482	"	"	
10448	"	"		10483	"	"	
10449	"	"		10484	"	"	
10450	"	"		10485	"	"	
10451	"	"		10486	"	"	
10452	"	"		10487	"	"	
10453	"	"		10488	"	"	
10454	"	"		10489	"	"	
10455	"	"		10490	"	"	
10456	"	"		10491	"	"	
10457	"	"		10492	"	"	
10458	"	"		10493	"	"	
10459	"	"		10494	"	"	
10460	"	"		10495	"	"	
10461	Skb	19		10496	"	"	
10462	"	"		10497	"	"	
10463	"	"		10498	"	"	
10464	"	"		10499	"	"	
10465	"	"		10500	"	"	
10466	"	"		10526	"	20	
10467	"	"		10527	"	"	
10468	"	"		10528	"	"	
10469	"	"		10529	"	"	
10470	"	"		10530	"	"	
10471	"	"					
10472	"	"					H-tegn. 1458 +2278
10473	"	"		10531	Skb	21	
10474	"	"		10532	"	"	
				10533	"	"	

T13
TYPE 1

Vogn nr.	Fabr.	Byggear	Merknad	Vogn nr.	Fabr.	Byggear	Merknad
10534	Skb	21		10665	Str	20	
10535	"	"		10666	LH	21	
10536	"	"		10667	"	"	
10537	"	"		10668	"	"	
10538	"	"		10669	"	"	
10539	"	"		10670	"	"	
10540	"	"		10671	"	"	
10541	"	"		10672	"	"	
10542	"	"		10673	"	"	
10543	"	"		10674	"	"	
10544	"	"		10675	"	"	
10545	"	"		10676	"	"	
10546	"	"		10677	"	"	
10547	"	"		10678	"	"	
10548	"	"		10679	"	"	
10549	"	"		10680	"	"	
10550	"	"		10681	"	"	
10591	Str	20		10682	"	"	
10592	"	"		10683	"	"	
10593	"	"		10684	"	"	
10594	"	"		10685	"	"	
10595	"	"		10686	"	"	
10596	"	"		10687	"	"	
10597	"	"		10688	"	"	
10598	"	"		10689	"	"	
10599	"	"		10690	"	"	
10600	"	"		10691	"	"	
			H-tegn. 1458+2140	10692	"	"	
10656	Str	20		10693	"	"	
10657	"	"		10694	"	"	
10658	"	"		10695	"	"	
10659	"	"		10696	"	"	
10660	"	"		10697	"	"	
10661	"	"		10698	"	"	
10662	"	"		10699	"	"	
10663	"	"		10700	"	"	
10664	"	"					

Vogn nr.	Fabr.	Byggear	Merknad	Vogn nr.	Fabr.	Byggear	Merknad
10914	LH	20		10957	FMV	23	
10915	"	"		10958	"	"	
10916	"	"		10959	"	"	
10917	"	"		10960	"	"	
10918	"	"		10961	"	"	
10919	"	"		10962	"	"	
10920	"	"		10963	"	"	
10921	"	"		10964	"	"	
10922	"	"		10965	"	24	
10923	"	"		10966	"	"	
			H-tegn. 1458 + 2278	10967	"	"	
10924	LH	21		10968	"	"	
10925	"	"		10969	"	"	
10926	"	"		10970	"	"	
10927	"	"		10971	"	"	
10928	"	"		10972	"	"	
10929	"	"		10973	"	"	
10930	"	"		10974	"	"	
10931	"	"					H-tegn. 1458 + 2140
10932	"	"		10975	FMV	25	
10933	"	"		10976	"	"	
10940	FMV	23		10977	"	"	
10941	"	"		10978	"	"	
10942	"	"		10979	"	"	
10943	"	"		10980	"	"	
10944	"	"		10982	"	"	
10945	"	"		10983	"	"	
10946	"	"		10984	"	"	
10947	"	"		10985	"	"	
10948	"	"		10986	"	"	
10949	"	"		10987	"	"	
10950	"	"		10988	"	"	
10951	"	"		10989	"	"	
10952	"	"		10990	"	"	
10954	"	"		10991	"	"	
10955	"	"		10992	"	"	
10956	"	"		10993	"	"	

Vogn nr.	Fabr.	Byggeår	Merknad	Vogn nr.	Fabr.	Byggeår	Merknad
10994	FMV	25		14563	Str	16	
10995	"	"		14564	"	"	
14529	Str	16		14565	"	"	
14530	"	"		14566	"	"	
14531	"	"		14567	"	"	
14532	"	"		14568	"	"	
14533	"	"					H-tegn. 1458 + 2278
14534	"	"		14569	FMV	24	
14535	"	"		14570	"	"	
14536	"	"		14571	"	"	
14537	"	"		14572	"	"	
14538	"	"		14573	"	"	
14539	"	"		14574	"	"	
14540	"	"		14575	"	"	
14541	"	"		14576	"	"	
14542	"	"		14577	"	"	
14543	"	"		14578	"	"	
14544	"	"					H-tegn. 1458 + 2140
14545	"	"		15536	Str	16	
14546	"	"		15537	"	"	
14547	"	"		15538	"	"	
14548	"	"		15539	"	"	
14549	"	"		15540	"	"	
14550	"	"		15541	"	"	
14551	"	"		15542	"	"	
14552	"	"		15543	"	"	
14553	"	"		15544	"	"	
14554	"	"		15545	"	"	
14555	"	"		15546	"	22	
14556	"	"		15547	"	"	
14557	"	"		15548	"	"	
14558	"	"		15549	"	"	
14559	"	"		15550	"	"	
14560	"	"		15551	"	"	
14561	"	"		15552	"	"	
14562	"	"	1)	15553	"	"	
				15554	"	"	

1) Höye endelemmer.

Vogn nr.	Fabr.	Byggeår	Merknad	Vogn nr.	Fabr.	Byggeår	Merknad
61087	Str	52		61122	Str	52	
61088	"	"		61123	"	"	
61089	"	"		61124	"	"	
61090	"	"		61125	"	"	
61091	"	"		61126	"	"	
61092	"	"		61127	"	"	
61093	"	"		61128	"	"	
61094	"	"		61129	"	"	
61095	"	"		61130	"	"	
61096	"	"		61131	"	"	
61097	"	"		61132	"	"	
61098	"	"		61133	"	"	
61099	"	"		61134	"	"	
61100	"	"		61135	"	53	
61101	"	"		61136	"	"	
61102	"	"		61137	"	"	
61103	"	"		61138	"	"	
61104	"	"		61139	"	"	
61105	"	"		61140	"	"	
61106	"	"		61141	"	"	
61107	"	"		61142	"	"	
61108	"	"		61143	"	"	
61109	"	"		61144	"	"	
61110	"	"		61145	"	"	
61111	"	"		61146	"	"	
61112	"	"		61147	"	"	
61113	"	"		61148	"	"	
61114	"	"		61149	"	"	
61115	"	"		61150	"	"	
61116	"	"		61151	"	"	
61117	"	"		61152	"	"	
61118	"	"		61153	"	"	
61119	"	"		61154	"	"	
61120	"	"		61155	"	"	
61121	"	"		61156	"	"	

T14
TYPE 1

Vogn nr.	Fabr.	Bygget	Merknad	Vogn nr.	Fabr.	Bygget	Merknad
61157	Str	53		61192	Edf	54	
61158	"	"		61193	"	"	
61159	"	"		61194	"	"	
61160	"	"		61195	"	"	
61161	"	"		61196	"	"	
61162	"	"		61197	"	"	2)
61163	"	"		61198	"	"	
61164	"	"		61199	"	"	
61165	"	"		61200	"	"	
61166	"	"		61201	"	"	
61167	"	"		61202	"	"	
61168	"	"		61203	"	"	
61169	"	"		61204	"	"	
61170	"	"		61205	"	"	
61171	"	"		61206	"	"	2)
61172	"	"		61207	"	"	
61173	"	"		61208	"	"	
61174	"	"		61209	"	"	
61175	"	"		61210	"	"	
61176	"	"		61211	"	"	
61177	"	"		61212	"	"	
61178	"	"		61213	"	"	
61179	"	"		61214	"	"	
61180	"	"		61215	"	"	
61181	"	"		61216	"	"	
61182	"	"		61217	"	"	2)
61183	"	"		61218	"	"	
61184	"	"		61219	"	"	
61185	"	"		61220	"	"	
61186	"	"		61221	"	"	
61187	"	"		61222	"	"	
61188	"	"		61223	"	"	2)
61189	"	"	1)	61224	"	"	
61190	"	"		61225	"	"	
61191	Edf	54		61226	"	"	

1) Utstyr for transport av trefiberplater. 2) Midlertidig utstyrt med skinner for transport av beholdere.

Vogn nr.	Fabr.	Byggeår	Merknad	Vogn nr.	Fabr.	Byggeår	Merknad
61366	Mbg	62					
61367	"	"					
61368	"	"					
61369	"	"					
61370	"	"					

T15

TYPE 1

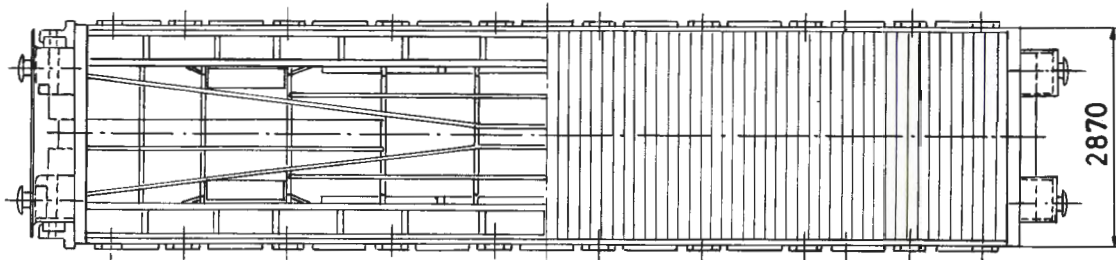
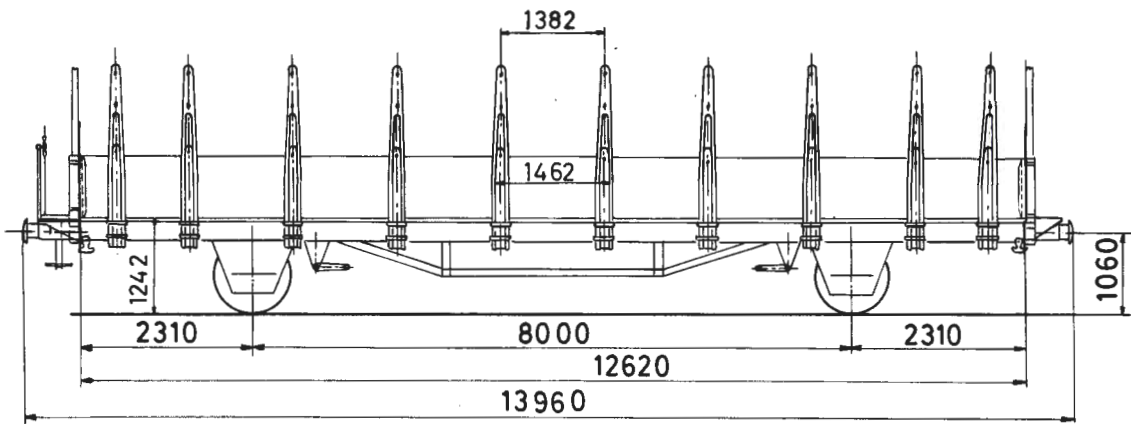

Bæreevne

	A	B	C
	19,0t	23,0t	27,0t
S	19,0t	23,0t	

Omtrentlig vognvekt	13,0t
Gulvflate	36,0m ²
Rominhold	29,0m ³
Hovedtegning	10165

PLATTFORMVOGN MED NEDLEGBARE JERNLEMMER

Vogn nr.	Fabr.	Byggeår	Merknad	Vogn nr.	Fabr.	Byggeår	Merknad
62000	Stv	62		62014	Stv	63	
62001	"	63		62015	"	"	
62002	"	"		62016	"	"	
62003	"	"		62017	"	"	
62004	"	"		62018	"	"	
62005	"	"		62019	"	"	
62006	"	"		62020	"	"	
62007	"	"		62021	"	"	
62008	"	"		62022	"	"	
62009	"	"		62023	"	"	
62010	"	"		62024	"	"	
62011	"	"		62025	"	"	
62012	"	"		62026	"	"	
62013	"	"		62027	"	"	

Vogn nr.	Fabr.	Byggeår	Merknad	Vogn nr.	Fabr.	Byggeår	Merknad
62028	Stv	63		62063	Stv	63	
62029	"	"		62064	"	"	
62030	"	"		62065	"	"	
62031	"	"		62066	"	"	
62032	"	"		62067	"	"	
62033	"	"		62068	"	"	
62034	"	"		62069	"	"	
62035	"	"		62070	"	"	
62036	"	"		62071	"	"	
62037	"	"		62072	"	"	
62038	"	"		62073	"	"	
62039	"	"		62074	"	"	
62040	"	"		62075	"	"	
62041	"	"		62076	"	"	
62042	"	"		62077	"	"	
62043	"	"		62078	"	"	
62044	"	"		62079	"	"	
62045	"	"		62080	"	"	
62046	"	"		62081	"	"	
62047	"	"		62082	"	"	
62048	"	"		62083	"	"	
62049	"	"		62084	"	"	
62050	"	"		62085	"	"	
62051	"	"		62086	"	"	
62052	"	"		62087	"	"	
62053	"	"		62088	"	"	
62054	"	"		62089	"	"	
62055	"	"		62090	"	"	1)
62056	"	"		62091	"	"	
62057	"	"		62092	"	"	
62058	"	"		62093	"	"	
62059	"	"		62094	"	"	
62060	"	"		62095	"	"	
62061	"	"		62096	"	"	
62062	"	"		62097	"	"	

1) Stålgulv. Vognvekt: 14,0 t. Bæreevne, A: 18,0 t, B: 22,0 t, C: 26,0 t. Som S-vogn, A: 18,0 t, BC: 22,0 t.

T15
TYPE 1

Vogn nr.	Fabr.	Byggeår	Merknad	Vogn nr.	Fabr.	Byggeår	Merknad
62098	Stv	63					
62099	"	"					
62100	"	"					
62101	"	"					
62102	"	"					
62103	"	"					
62104	"	"					
62105	"	"					
62106	"	"					
62108	"	"					
62109	"	"					
62110	"	"					
62111	"	"					

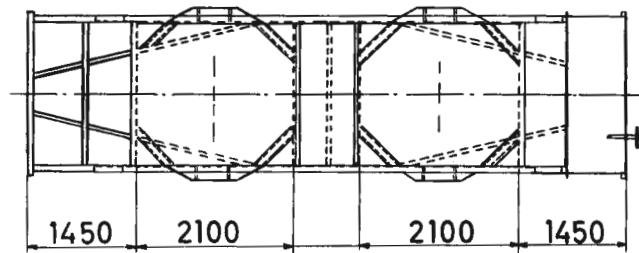
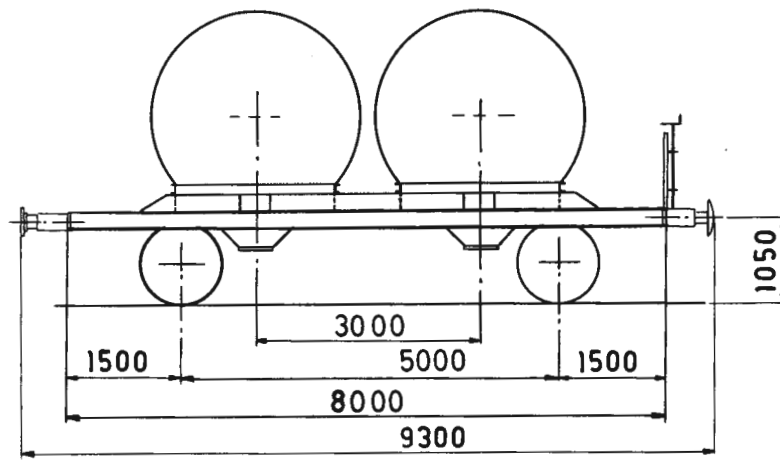

Bæreevne

A	B	C
21,0t	21,0t	

Omtrentlig vognvekt 9,0 t

Gulvflate —

Rominhold 22,6 m³

Hovedtegning 8679
+10095

SEMENTTRANSPORTVOGN

Vogn nr.	Fabr.	Byggeår	Merknad	Vogn nr.	Fabr.	Byggeår	Merknad
75000	Edf	37					
75001	"	46					
75002	"	47					
75003	"	46					

U4
TYPE 2

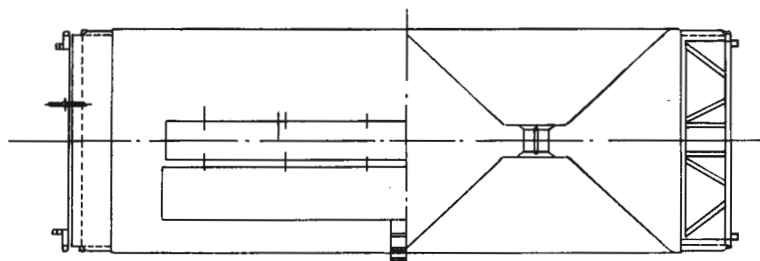
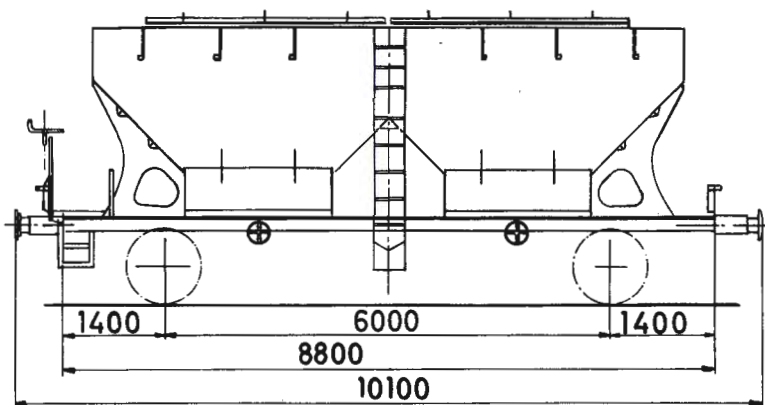

Omtrentlig vognvekt 11,0-12,0t

" bærevne 18,5-19,0t

Rominnhold 31,0 m³

Hovedtegning 8496

KORNTRANSPORTVOGN

Vogn nr.	Fabr.	Byggeår	Merknad	Vogn nr.	Fabr.	Byggeår	Merknad
75100	1)	41		75115	3)	42	
75101	"	"		75116	"	"	
75102	"	"		75117	"	"	
75103	"	"		75118	"	"	
75104	"	42		75119	"	41	
75105	"	41		75120	"	43	
75106	2)	40		75121	"	41	
75107	"	41		75122	5)	43	
75108	"	"		75123	"	"	
75109	"	42		75124	"	"	
75110	"	41		75125	"	42	
75111	"	"		75126	"	41	
75112	"	42		75127	"	42	
75113	3)	4)		75128	"	41	
75114	"	42		75129	"	"	

1) Omb. i Drmi 1960. 2) Omb. i Drm i 1961. 3) Omb. i Drm i 1962.

4) Oppr. byggeår ukjent. 5) Omb. i Drm i 1963.

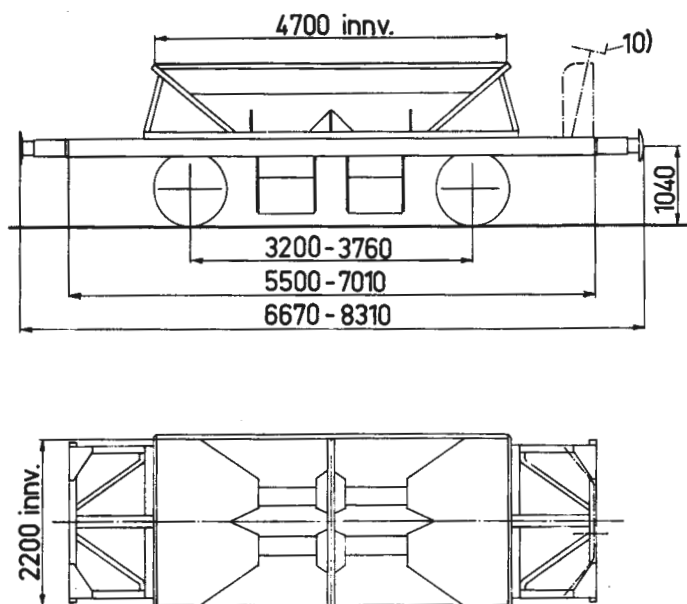

Omtrentlig vognvekt 5,5-8,0 t
 " last 11,0-11,5t
 Gulvflate -
 Rominnhold 7,5 m³
 Hovedtegning 6291, 6439,
 6624 eller 6624 + 7938

BUNNTØMMINGSVOGN

Vogn nr.	Fabr.	Byggear	Merknad	Vogn nr.	Fabr.	Byggear	Merknad
			H-tegn. 6291	16715	Skb	09	2)
16701	Skb	97	1) 11)	16716	"	"	2)
16702	"	12	2)	16717	"	"	2)
16703	"	"	2)	16718	"	"	2) 11)
16704	"	"	2) 11)	16719	"	"	2)
16705	"	09	2)	16720	"	"	2) 11)
16706	"	"	2)	16721	"	"	2)
16707	"	"	2)	16722	Edf	01	3)
16708	"	"	2)	16723	"	"	3) 11)
16709	"	"	2)	16724	x	76/82	5) x) Str, Skb og Atl
16710	"	"	2)	16725	Skb	02	3) 11)
16711	"	"	2)	16726	Str	97	3) 11)
16712	"	"	2)	16727	Skb	00	3) 11)
16713	"	"	2)	16728	Str	92	4) 11)
16714	"	"	2)	16729	Atl	76	5) 11)

Opprinnelige h-tegninger: 1) 376, 2) 1033, 3) 400, 4) 47, 5) Ukjent.

10) Bare vogner med tilleggstegeting 7938 har bremseplattform.

11) Bevegelsesanordn. for tömmeløker etter tegn. 7536 og 10163.

Vogn nr.	Fabr.	Byggear	Merknad	Vogn nr.	Fabr.	Byggear	Merknad
16730	Str	91	4)	16763	MMV	99	3)
16731	Skb	89	4)	16764	NHJ	"	5)
H-tegn. 6439				16765	Str	97	3) 11)
16732	KvB	93	6)	16766	"	98	3) 11)
16733	Skb	98	7)	16767	"	97	3)
16734	Str	"	5) 11)	16769	Skb	00	3) 11)
16735	Skb	00	3) 11)	16770	"	"	3)
16736	Str	99	5) 11)	16771	Str	98	3)
16737	MMV	"	6)	16772	Edf	00	3) 11)
16738	Str	"	6)	16773	Atl	76	5)
16739	"	97	5)	16774	Skb	00	3) 11)
16740	"	99	5) 11)	16775	Str	99	3) 11)
16741	"	90	5) 11)	16776	"	00	3)
16742	Str	92	6)	16777	"	99	3)
16743	KvB	93	6)	16778	Skb	00	3) 11)
16744	Str	97	6) 11)	16779	"	"	3) 11)
16745	Atl	77	5) 11)	16780	"	"	3) 11)
16746	MMV	99	3) 11)	16781	Str	"	3) 11)
16747	Str	98	6)	16782	"	90	3)
16748	Edf	00	3) 11)	16783	"	"	3) 11)
16749	Str	97	3) 11)	16784	"	"	3)
16750	Edf	01	6) 11)	16785	"	98	5) 11)
16751	Skb	00	3) 11)	16786	"	00	5)
16752	Atl	76	5) 11)	16787	"	97	3)
16753	Str	90	5)	16788	Skb	00	3) 11)
16754	"	98	5) 11)	16789	"	"	3) 11)
16755	"	"	5) 11)	16790	"	"	3)
16756	"	"	5) 11)	16791	Str	92	6) 11)
16757	"	00	3) 11)	16792	"	89	1) 11)
16758	"	99	5) 11)	16793	"	92	6) 11)
16759	Skb	00	3)	16794	Edf	00	3) 11)
16760	Str	95	5) 11)	16795	Str	99	3)
16761	"	91	5) 11)	16796	MMV	"	3)
16762	"	97	3)				

Opprinnelige h-tegninger: 1) 376, 3) 400, 4) 47, 5) Ukjent, 6) 3070, 7) B62. 11) Bevegelsesanordn. for tömmeluger etter tegn. 7536 og 10163.

Vogn nr.	Fabr.	Byggeår	Merknad	Vogn nr.	Fabr.	Byggeår	Merknad
			H-tegn. 6624	16831	Str	00 5) 11)	
16797	Str	00 5)		16832	"	97 6) 11)	
16798	"	99 5) 11)		16833	Oslo	15 6) 11)	
16799	"	00 5)		16834	Atl	77 5) 11)	
16800	x	22 8)	x) Skb/Edf	16835	"	" 5) 11)	
16801	Str	99 5)		16836	MMV	95 6)	
16802	x	22 8) 11)	x) Skb/Edf	16837	Oslo	15 5)	
16803	AaB	12 8)		16838	"	16 5) 11)	
16804	HJ	14 8)		16839	Atl	77 5) 11)	
16805	x	22 8)	x) Skb/Edf	16840	Skb	21 8) 11)	
16806	AaB	12 8)		16841	Str	00 5) 11)	
16807	HJ	14 8) 11)		16842	Edf	06 6) 11)	
16808	NHJ	99 5) 11)		16843	KvB	93 6) 11)	
16809	Str	" 3) 11)		16844	Oslo	13 6) 11)	
16810	Atl	77 5)		16845	"	14 5)	
16811	Str	91 5) 11)		16846	AaB	12 6)	
16812	"	76 4)		16847	Str	92 6)	
16813	Atl	" 5)		16848	Oslo	14 5) 11)	
16814	AaB	08 5) 11)		16849	Skb	00 6)	
16815	Atl	77 5)		16850	Edf	" 6)	
16816	Oslo	15 5) 11)		16851	Oslo	14 5)	
16817	Str	00 5) 11)		16852	"	16 6) 11)	
16818	x	22 8)	x) Skb/Edf	16853	"	15 5)	
16819	Str	08 9)		16854	KvB	93 6)	
16820	Atl	77 5)		16855	Edf	06 6)	
16821	x	22 8)	x) Skb/Edf	16856	Oslo	13 5)	
16822	Oslo	14 5)		16857	Edf	01 6)	
16823	Str	07 5) 11)		16858	Skb	00 6) 11)	
16824	"	01 1) 11)		16859	Oslo	14 5) 11)	
16825	Oslo	15 5) 11)		16860	Str	00 6) 11)	
16826	Str	03 12)		16861	Ldv	92 6) 11)	
16827	"	08 9)		16862	Edf	01 6)	
16828	AaB	" 5) 11)		16863	Atl	76 6) 11)	
16829	Atl	77 5) 11)		16864	Str	00 5)	
16830	Oslo	14 5) 11)		16865	"	" 5) 11)	

Opprinnelige h-tegninger: 1) 376, 3) 400, 4) 47, 5) Ukjent, 6) 3070, 8) 876, 9) 815, 12) 690. 11) Bevegelsesanordn. for tömmeluker etter tcgn. 7536 og 10163.

Vogn nr.	Fabr.	Rykketår	Merknad	Vogn nr.	Fabr.	Rykketår	Merknad
16866	HJ	14	6) 11)	16901	Edf	06	6) 11)
16867	Str	00	6) 11)				h-tegn. 6624+7938
16868	AaB	12	6) 11)	16902	Skb	17	6)
16869	Oslo	18	6)	16903	HJ	14	6)
16870	Skb	00	6)	16904	Edf	00	6)
16871	Atl	77	5)	16905	Skb	"	6)
16872	Ldv	92	6)	16906	Edf	06	6)
16873	Str	00	6)	16907	Skb	00	6)
16874	Oslo	15	5) 11)	16908	Edf	01	6)
16875	HJ	14	6)	16909	Str	98	6)
16876	AaB	12	6) 11)	16910	Atl	15	6)
16877	"	"	6)	16911	Edf	06	6)
16878	Ldv	92	6)	16912	Str	00	6)
16879	Edf	01	1)	16913	"	97	6)
16880	Oslo	14	6)	16914	Edf	01	6)
16881	Skb	00	6) 11)	16915	Skb	00	6)
16882	Str	"	5)	16916	Str	97	6)
16883	AaB	12	6) 11)	16917	Edf	00	6)
16884	Edf	01	6)	16918	"	"	6)
16885	Atl	76	5) 11)	16919	Str	"	6)
16886	Str	97	6)	16920	"	01	7)
16887	Oslo	13	6) 11)	16921	Edf	00	6)
16888	Edf	06	6) 11)	16922	Atl	76	5)
16889	Oslo	15	6)	16924	Str	99	6)
16890	Str	93	6) 11)	16925	Edf	01	6)
16891	KvB	"	4)	16926	"	"	6)
16892	Atl	76	5) 11)	16927	Oslo	17	6)
16893	Str	97	6) 11)	16928	Ldv	92	6)
16894	"	"	6) 11)	16929	Str	00	6)
16895	HJ	14	6) 11)	16930	Oslo	15	6)
16896	Str	98	6)	16931	Str	00	6)
16897	Oslo	13	6)	16932	"	99	6)
16898	Str	99	5)	16933	AaB	12	6)
16899	Oslo	14	6)	16934	Str	99	6)
16900	Str	00	6) 11)				

Opprinnelige h-tegninger: 1) 376, 4) 47, 5) Ukjent, 6) 3070, 7) 614.
11) Bevegelsesanordn. for tömmeluger etter tegn. 7536 og 10163.

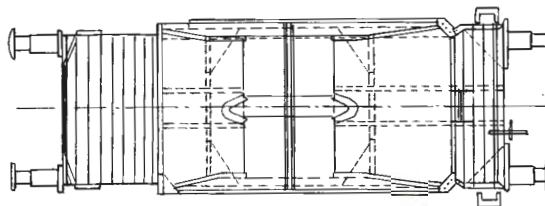
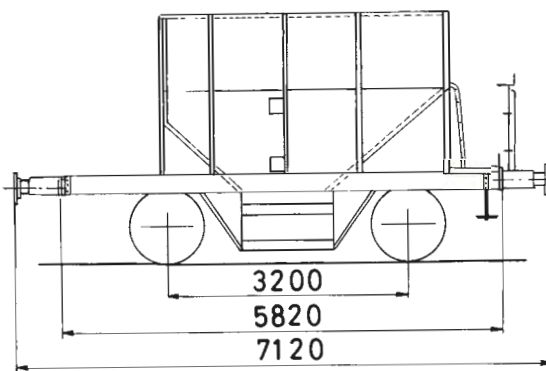

Omtrentlig vognvekt 7,0-8,0t
 " bæreevne 19,0-20,5t
 Rominnhold 1) 7,2m³ 2) 15,8m³
 Hovedtegning 2510

-BUNNTÖMMINGSVOGN (KISVOGN)

Vogn nr.	Fabr.	Byggeår	Merknad	Vogn nr.	Fabr.	Byggeår	Merknad
17593	Str	23					
17594	"	"					
17595	"	"					
17596	"	"					
17597	"	"					
17599	"	"					
17600	Edf	29					

1) Ved lastmerke I. 2) Ved lastmerke II.

Ø04

TYPE 1

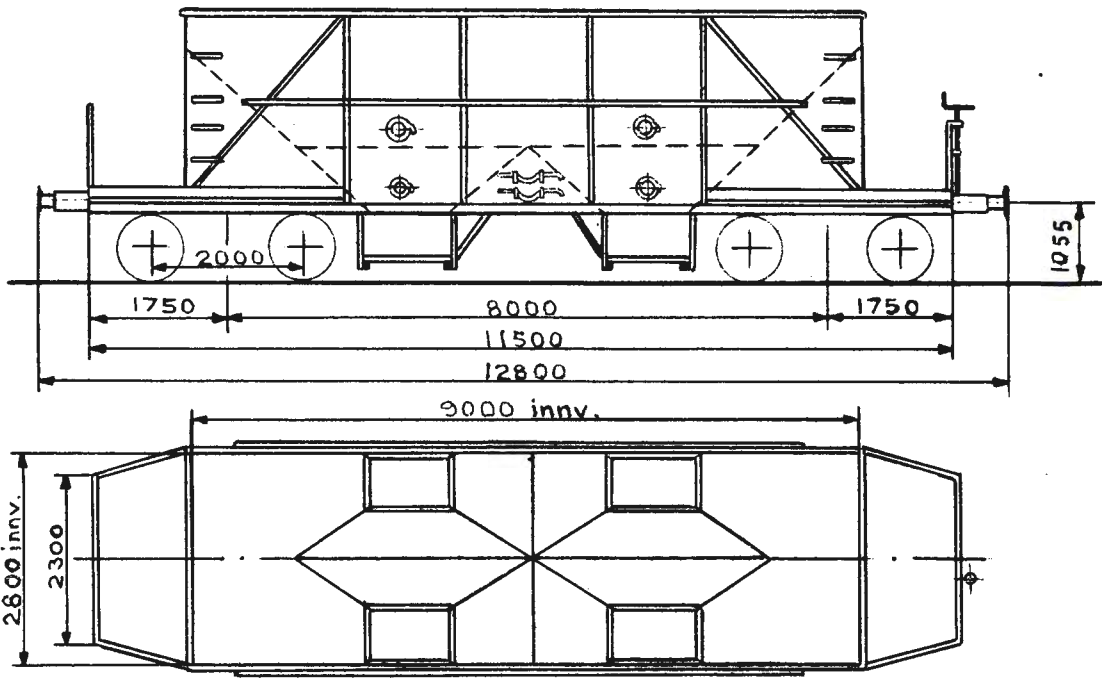

Esereevne

A	B	C
40,0t	40,0t	40,0t

Omtrentlig vognvekt 20,0 t
 Gulvflate -
 Rominnhold 45,5 m³
 Hovedtegning 3420

BUNNTÖMMINGSVOGN

Vogn nr.	Fabr.	Byggeår	Merknad	Vogn nr.	Fabr.	Byggeår	Merknad
74000	Edf	33					
74001	"	"					

Øf 4
TYPE 1

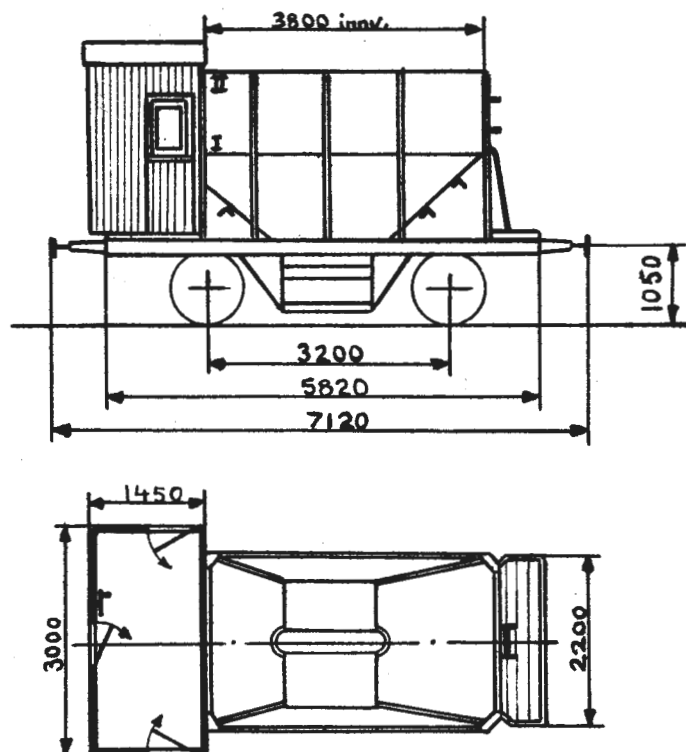

Omtrentlig vognvekt 8,5- 9,0 t
 " bæreevne 19,0-19,5 t
 Gulvflate -
 Rominnhold 7,2 m³ 1), 15,8 m³ 2)
 Hovedtegning 2510

BUNNTÖMMINGSVOGN (KISVOGN)

Vogn nr.	Fabr.	Byggeår	Merknad	Vogn nr.	Fabr.	Byggeår	Merknad
17598	Str	23					
17599	"	"					
17601	Edf	29					
17602	"	"					

1) Ved lastemerke I. 2) Ved lastemerke II.

