

751

Trykk nr. 751

Tjenesteskifter utgitt av Norges Statsbaner.

Hovedstyret.

M



ILLUSTRERT FORTEGNELSE

OVER

PERSONVOGNER

inklusive post og konduktørvogner

NORMALSPOR

1963-1966

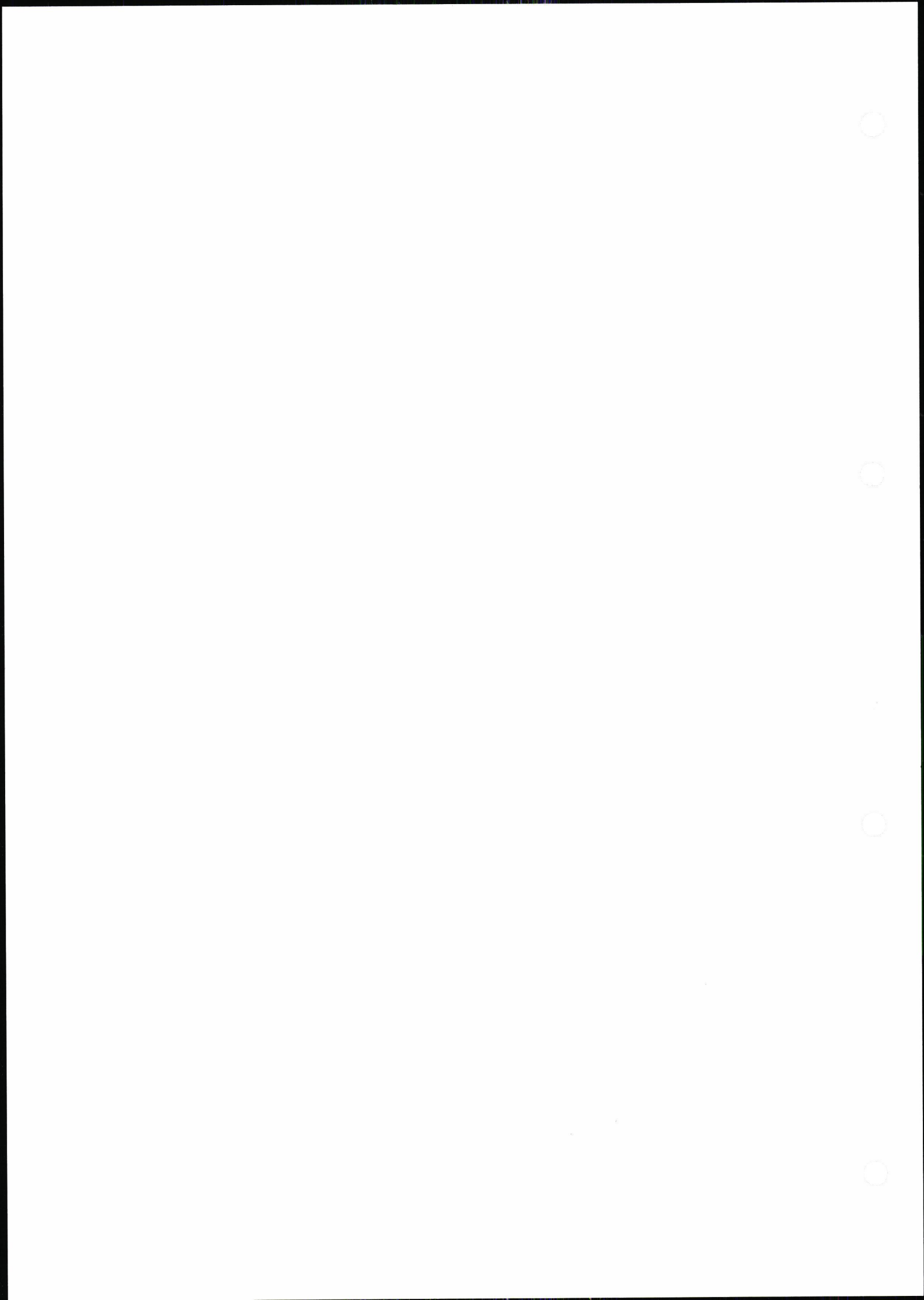

VOGNE NE ORDNET I NUMMERORDEN

Nr.	Litra	Type	Nr.	Litra	Type	Nr.	Litra	Type	Nr.	Litra	Type
9	BFo3b	3	136	ABo2b	3	214	BFo2c	3	308	Bo3m	2
16	Zo	1	137	"	"	215	"	"	310	"	"
31	Zuo	4	139	"	"	216	"	"	311	"	"
34	Bo3k	3	151	BF2a	1	217	Bo3a	1	328	Bo2a	1
35	Bo3b	7	153	Bo2b	2	219	"	"	334	"	"
36	Bo3b	6	154	"	"	220	Bo3a	2	337	"	"
37	"	"	156	"	"	221	"	"	341	Bo2b	2
39	Bo4c	1	157	"	"	222	"	"	342	"	"
44	"	"	160	Bo3c	1	223	"	"	343	"	"
47	"	"	164	Bo2a	1	224	Bo2b	3	344	"	"
67	BFo3a	2	166	Zuo	3	225	"	"	345	"	"
78	Bo4b	4	168	Bo2a	1	226	"	"	346	"	"
80	Bo3b	1	171	Bo2b	2	233	Bo4d	5	347	"	"
81	"	"	172	"	"	237	BF3b	1	348	ABo2b	3
82	"	"	173	"	"	240	"	"	349	Bo2c	6
83	"	"	174	"	"	245	BFo2c	5	351	"	"
84	Bo3b	2	175	Bo3a	1	246	"	"	352	ABo2b	3
85	"	"	176	"	"	247	Ao2b	1	428	Zuo	3
86	"	"	177	"	"	248	Ao2c	1	432	DFo-22	4
87	Bo3b	3	179	"	"	280	Bo2b	2	433	DFo-16	1
88	"	"	180	Bo3c	4	281	"	"	434	DFo-16	2
89	"	"	182	Bo2-3a	1	282	"	"	435	DFo-32	3
94	BFo2c	1	183	BFo2b	6	284	"	"	436	DFo-16	2
97	BFo2c	3	185	BFo2c	3	285	"	"	450	Bo3d	1
98	"	"	186	Bo3a	1	286	Bo3c	1	451	"	"
100	Ao	2	187	Bo3c	4	287	"	"	452	"	"
102	WLBolb	1	188	BFo2c	2	288	"	"	453	"	"
103	"	"	199	WLBola	1	289	"	"	473	Bo2c	5
105	WLAola	1	200	"	"	290	Bo2b	2	476	Bo2b	1
107	BFo2a	5	202	WLBolb	1	291	"	"	477	"	"
118	Ao	3	204	BFo2a	5	292	"	"	499	Eo	2
119	Eo	2	205	Zuo	3	293	"	"	500	"	"
120	BFo2c	3	207	WLABolb	1	294	Bo3c	2	501	Bo2c	5
121	"	"	208	WLBolb	1	296	BFo2c	2	502	"	"
122	"	"	209	Ao2b	1	305	Bo3c	2	503	Bo2b	6
123	"	"	210	WLAola	1	306	Bo3m	1	504	Bo2c	7
135	BZo2a	1	213	BFo2c	3	307	Bo2b	6	505	Bo2b	6

VOGNE NE ORDNET I NUMMERIRDEN

Nr.	Litra	Type	Nr.	Litra	Type	Nr.	Litra	Type	Nr.	Litra	Type
506	Bo2b	6	568	Bo2b	2	635	Bo3a	1	691	BF2b	1
507	"	"	569	"	"	636	"	"	693	"	"
508	"	"	570	"	"	637	Bo2b	2	695	"	"
510	Bo2a	2	571	"	"	638	"	"	697	BF3a	2
511	"	"	572	"	"	639	"	"	703	Eo	2
512	DFo-16	3	573	Bo2c	6	640	"	"	705	WLABola	1
513	"	"	574	"	"	643	Bo3c	4	707	Bo3c	2
514	BFo2b	3	575	BFo2b	6	644	Eo	6	724	BFo2c	5
515	"	"	576	"	"	645	Bo3c	2	739	Bo3k	1
517	DFo-22	3	577	"	"	646	Eo	6	740	Bo2c	6
539	Bo2b	1	578	"	"	647	BFo2c	2	741	Bo3k	2
540	"	"	580	Bo2b	2	648	"	"	742	Bo3c	1
541	"	"	581	Ao2d	1	649	BFo2b	6	743	"	"
542	Bo2c	5	586	Bo4c	1	650	"	"	744	Bo2b	2
543	"	"	587	"	"	651	Bo3a	1	745	"	"
544	"	"	601	"	"	653	WLBold	1	746	Bo3c	1
545	BFo2b	4	603	Bo3c	4	654	Bo2b	3	747	Bo3c	2
547	BF3b	2	604	BFo2b	8	655	"	"	748	Bo3c	1
548	"	"	605	Bo4c	1	656	"	"	749	"	"
549	"	"	606	"	"	657	"	"	769	Bo2b	1
550	ABo3b	3	607	"	"	658	Bo3c	4	770	Bo2b	2
551	"	"	608	"	"	659	Bo3a	2	772	BEo3a	1
552	"	"	609	"	"	660	Bo2b	3	773	Bo3c	1
553	Bo3c	1	610	"	"	661	"	"	774	"	"
554	"	"	620	BDFo2-11	3	662	"	"	775	BDFo2-11	7
555	"	"	621	"	"	663	Bo3a	2	776	BFo2b	6
556	"	"	622	DFo-32	2	664	"	"	777	Zuo	3
557	"	"	623	Bo2b	2	665	Bo3c	2	778	BFo2b	2
558	"	"	624	BFo2b	7	666	"	"	779	BFo2b	4
560	"	"	625	"	"	679	BF2b	1	780	BFo2b	6
561	"	"	626	BFo2b	8	681	Bo3b	5	781	"	"
562	"	"	627	BFo2a	7	682	"	"	782	Bo2b	2
563	Bo2b	2	629	WLABola	1	683	Bo3b	4	783	"	"
564	"	"	631	Bo3a	1	684	"	"	784	BFo2c	6
565	"	"	632	BFo2c	6	686	BF2a	2	785	BFo2b	7
566	"	"	633	Bo3c	4	687	"	"	787	Do-39	1
567	"	"	634	Bo3a	1	690	Ao3a	1	788	Bo3a	1

VOGNENE ORDNET I NUMMERORDEN

Nr.	Litra	Type	Nr.	Litra	Type	Nr.	Litra	Type	Nr.	Litra	Type
789	Bo3c	1	887	Bo3a	2	946	Ao3a	1	995	WLAola	1
790	"	"	888	BFo2c	2	947	"	"	1001	BF3a	1
791	"	"	889	Bo3c	1	948	Bo3c	3	1002	"	"
792	BFo2b	6	892	"	"	949	Bo3m	1	1007	F	5
793	"	"	893	"	"	950	Ao2c	1	1023	Fd	4
794	"	"	894	"	"	951	Bo2c	5	1024	"	"
795	"	"	895	"	"	952	"	"	1025	Fd	1
796	BFo2b	7	896	"	"	953	"	"	1026	"	"
797	"	"	897	"	"	954	Zuo	3	1027	"	"
799	BFo2c	3	898	Bo3m	1	955	Bo2b	6	2007	F	3
804	DFo-29	1	899	Bo3c	3	956	"	"	2011	F	6
805	BFo2a	3	900	Ao3a	1	957	Bo2a	2	2019	F	7
806	BFo2c	1	906	BFo2c	5	958	"	"	2022	F	10
807	"	"	908	Bo2a	1	959	"	"	2023	F	15
808	DFo-29	1	909	"	"	963	BDFo2-7	1	2024	F	10
811	Ao2c	1	912	DFo-22	2	964	"	"	2025	F	11
812	BFo2b	4	917	BDFo2-11	2	965	BFo2b	1	2026	"	"
813	Bo3c	1	919	Bo3m	1	966	Bo4b	3	2027	"	"
814	Bo3a	1	920	Bo3c	3	967	"	"	2028	"	"
815	BFo2b	5	923	Bo2b	6	968	"	"	2029	F	15
836	Zuo	3	924	ABZo2a	2	969	"	"	2030	F	11
837	BFo2b	2	925	Bo2b	6	970	"	"	3009	F	9
841	Bo2a	1	926	"	"	971	BFo3b	6	3010	"	"
842	"	"	927	"	"	972	"	"	3011	"	"
849	"	"	928	Bo2c	5	973	Bo3c	3	3012	"	"
852	BFo2c	3	929	"	"	974	"	"	3030	F	10
875	DFo-22	5	930	"	"	975	"	"	3031	"	"
876	Bo2b	2	931	Bo2a	2	977	BFo2b	4	3033	F	11
877	"	"	932	"	"	978	Eo	5	3034	"	"
878	"	"	934	"	"	979	"	"	3035	"	"
879	BFo2c	2	935	"	"	980	"	"	3036	"	"
880	Bo2b	2	939	DFZo-16	2	981	Bo2b	1	3037	"	"
882	BFo2c	3	940	BFo2b	3	982	"	"	3038	"	"
883	Bo2c	6	941	"	"	986	WLAola	1	3039	"	"
884	Bo2b	2	942	"	"	989	Ao3a	1	3040	Fd	1
885	"	"	943	Bo2a	2	990	"	"	3041	"	"
886	Bo3a	2	945	Eo	5	991	WLBolb	1	3042	"	"

VOGNENE ORDNET I NUMMERORDEN

Nr.	Litra	Type	Nr.	Litra	Type	Nr.	Litra	Type	Nr.	Litra	Type
3043	Fd	1	6019	F	11	17956	FZo	2	18039	BEo3a	1
3045	Fo	4	6020	"	"	18001	BFo2b	5	18040	Bo3a	1
3046	"	"	6021	"	"	18002	ABo2b	3	18041	"	"
3047	"	"	6022	"	"	18003	WLBolb	1	18042	Bo2b	2
5009	F	8	6025	F	9	18005	WLBola	1	18043	BFo2b	6
5010	F	15	7001	F	2	18006	Eo	2	18044	"	"
5011	F	10	8002	"	"	18007	Bo3c	1	18047	WLAola	1
5012	F	8	8402	F	"	18008	"	"	18048	WLBolb	1
5014	F	9	9001	BF	"	18009	BFo-16	1	18049	Bo3c	2
5015	F	10	9004	F	"	18010	BFo-32	1	18052	BFo2b	6
5016	"	"	13022	F	"	18011	Eo	2	18053	Bo3c	4
5017	Fo	"	14002	F	"	18012	Bo2b	2	18054	Bo3a	1
5018	"	"	14003	F	"	18013	"	"	18055	ABo3b	3
5019	"	"	14005	F	"	18014	"	"	18056	WLBola	1
5020	F	11	14006	"	"	18015	BFo2c	2	18057	Bo2b	2
5021	"	"	14007	"	"	18016	BFo2c	3	18058	"	"
5022	"	"	14008	"	"	18017	"	"	18059	Bo3c	1
5023	"	"	14009	"	"	18018	ABo2b	3	18060	"	"
5024	"	"	14010	F	"	18019	BFo2b	6	18061	"	"
5634	F	10	14011	"	"	18020	BFo2b	7	18062	Bo2b	2
5635	"	"	14012	"	"	18021	BFo2b	6	18064	Ao2b	1
5678	Fo	5	14013	Fo	3	18022	"	"	18065	ABo2b	3
5679	"	"	14014	"	"	18023	BFo2b	7	18066	"	"
5680	FZo	2	14015	"	"	18024	ABo2b	3	18074	WLABolb	1
5681	"	"	14952	F	16	18025	Bo2c	6	18075	"	"
6001	F	6	15008	F	8	18026	Bo2b	2	18077	Bo3a	1
6007	"	"	15009	"	"	18027	"	"	18078	"	"
6008	F	8	15011	F	5	18028	"	"	18080	BFo2a	7
6010	F	9	15012	F	8	18029	BFo2b	6	18081	BDFo2-7	2
6011	"	"	15013	"	"	18030	Bo3a	1	18082	"	"
6012	"	"	15014	"	"	18031	Bo3c	1	18083	"	"
6013	"	"	15015	"	"	18033	BDFo2-11	6	18085	BDFo2-11	6
6014	F	10	15019	Fo	4	18034	BDFo2-11	3	18086	BDFo2-11	3
6015	"	"	17950	F	11	18035	Ao2b	1	18090	BDFo2-11	6
6016	"	"	17952	F	10	18036	Bo3c	2	18091	Fo	9
6017	F	11	17953	"	"	18037	Bo2b	2	18092	BDFo2-7	2
6018	"	"	17954	"	"	18038	DFo-22	2	18099	Bo2b	2

VOGNENE ORDNET I NUMMERORDEN

Nr.	Litra	Type	Nr.	Litra	Type	Nr.	Litra	Type	Nr.	Litra	Type
18100	BFo2b	6	18149	Bo3c	2	19952	Fo	6	21017	WLBold	2
18102	WLBola	1	18169	BFo3b	5	19953	Fo	7	21018	"	"
18103	"	"	18170	"	"	19954	Fdeo	1	21019	"	"
18104	BFo2b	7	18171	Bo3d	2	19955	"	"	21020	"	"
18105	BFo2b	6	18172	"	"	20051	F	10	21021	"	"
18107	Do-39	2	18173	"	"	20052	"	"	21022	"	"
18108	BFo4b	6	19004	Fde	2	20053	"	"	21023	"	"
18109	BDFo2-11	3	19900	BF3	1	20054	F	11	21024	"	"
18110	Bo3c	4	19901	BF3	2	20055	"	"	21025	"	"
18116	WLBola	1	19902	BF3	1	20056	"	"	21026	"	"
18118	Bo4d	2	19903	"	"	20057	"	"	21027	"	"
18119	"	"	19904	"	"	20058	Fo	2	21028	"	"
18120	"	"	19905	"	"	20059	"	"	21029	"	"
18121	"	"	19906	"	"	20060	Fdo	1	21030	"	"
18122	"	"	19907	"	"	20061	"	"	21031	"	"
18123	"	"	19908	"	"	20063	Fo	2	21032	"	"
18124	"	"	19909	"	"	20064	Fo	3	21033	"	"
18127	ABo3b	3	19911	"	"	20065	"	"	21034	"	"
18128	"	"	19912	"	"	20066	"	"	21035	WLABolc	1
18129	Bo3a	1	19913	"	"	20773	F	11	21036	"	"
18130	BFo2b	7	19914	"	"	20774	"	"	21037	"	"
18131	Bo2b	3	19915	"	"	21001	WLAolb	1	21038	"	"
18132	"	"	19916	"	"	21002	"	"	21039	"	"
18133	"	"	19918	BF3	3	21003	WLBold	3	21040	"	"
18134	"	"	19919	"	"	21004	"	"	21041	"	"
18135	"	"	19920	BF3	1	21005	"	"	21042	"	"
18136	Bo3a	2	19921	"	"	21006	"	"	21043	"	"
18137	"	"	19922	Bo3g	1	21007	WLBola	2	21044	"	"
18138	Bo3c	2	19923	"	"	21008	"	"	21045	"	"
18139	BEo3a	1	19924	"	"	21009	"	"	21046	"	"
18140	"	"	19925	"	"	21010	WLAolb	2	21047	"	"
18143	Bo2b	3	19926	"	"	21011	"	"	21048	"	"
18144	"	"	19927	"	"	21012	"	"	21049	"	"
18145	"	"	19928	"	"	21013	"	"	21050	"	"
18146	Bo3c	2	19929	"	"	21014	"	"	21051	"	"
18147	"	"	19930	Bo	1	21015	"	"	21052	"	"
18148	"	"	19951	Fo	6	21016	WLBold	2	21053	"	"

VOGNE NE ORDNET I NUMMERORDEN

Nr.	Litra	Type	Nr.	Litra	Type	Nr.	Litra	Type	Nr.	Litra	Type
21054	WLABolc	1	21303	DFo-32	4	21519	BFo2ak	1	25006	Bo2d	1
21055	"	"	21304	DFo-37	1	21520	"	"	25007	"	"
21056	"	"	21305	"	"	21521	"	"	25008	"	"
21057	"	"	21306	"	"	21522	"	"	25009	"	"
21058	"	"	21307	"	"	21523	"	"	25010	"	"
21059	"	"	21308	DFo-30	1	21524	"	"	25011	"	"
21060	"	"	21309	"	"	23101	F	10	25012	"	"
21061	"	"	21310	"	"	23102	"	"	25013	"	"
21062	"	"	21311	"	"	24001	Ao	5	25014	"	"
21063	"	"	21312	"	"	24101	ABo2c	1	25015	"	"
21064	"	"	21313	"	"	24102	"	"	25016	"	"
21065	"	"	21314	DFo-22	6	24103	"	"	25017	"	"
21066	"	"	21315	"	"	24104	ABo2-3a	1	25018	"	"
21067	"	"	21316	"	"	24105	"	"	25019	"	"
21068	"	"	21317	"	"	24106	"	"	25020	"	"
21069	"	"	21318	DFo-37	1	24107	"	"	25021	"	"
21070	"	"	21319	"	"	24108	"	"	25022	"	"
21071	"	"	21320	"	"	24109	"	"	25023	"	"
21072	"	"	21321	"	"	24110	"	"	25024	"	"
21073	"	"	21501	BFo2d	1	24111	"	"	25025	"	"
21074	"	"	21502	BFo2dk	1	24112	"	"	25026	"	"
21075	"	"	21503	BFo2d	1	24113	"	"	25027	"	"
21076	"	"	21504	BFo2d	2	24114	"	"	25028	"	"
21077	"	"	21505	"	"	24115	"	"	25029	"	"
21078	"	"	21506	"	"	24116	"	"	25030	"	"
21079	"	"	21507	BFo2dk	2	24117	"	"	25501	Bo3p	1
21080	"	"	21508	BFo2d	2	24118	"	"	25502	"	"
21081	"	"	21509	"	"	24119	"	"	25503	Bo3f	1
21082	"	"	21510	"	"	24120	"	"	25504	"	"
21251	Eo	4	21511	"	"	24121	"	"	25505	"	"
21252	"	"	21512	BFo2dk	2	24122	"	"	25506	"	"
21253	"	"	21513	BFo2d	2	24123	"	"	25507	"	"
21254	"	"	21514	"	"	25001	Bo2d	1	25508	"	"
21255	"	"	21515	BFo2ak	1	25002	"	"	25509	"	"
21256	" "	"	21516	"	"	25003	"	"	25510	"	"
21301	DFo-32	4	21517	"	"	25004	"	"	25511	Bo3p	1
21302	"	"	21518	"	"	25005	"	"	25512	Bo3f	1

VOGNENE ORDNET I NUMMERORDEN

Nr.	Litra	Type	Nr.	Litra	Type	Nr.	Litra	Type	Nr.	Litra	Type
25513	Bo3f	1	25550	Bo3l	1						
25514	"	"	25551	"	"						
25515	"	"	25552	"	"						
25516	"	"	25553	"	"						
25517	"	"	25554	"	"						
25518	"	"	25555	"	"						
25519	"	"	25556	"	"						
25520	"	"	25557	"	"						
25521	"	"	25558	"	"						
25522	Bo3p	1	25559	"	"						
25523	"	"	25560	"	"						
25524	"	"	25561	"	"						
25525	Bo3f	1	25562	"	"						
25526	"	"	25563	Bo3l	2						
25527	Bo3p	1	25564	"	"						
25528	"	"	25565	"	"						
25529	"	"	25566	"	"						
25530	Bo3f	1	25567	"	"						
25531	Bo3l	1	25568	"	"						
25532	"	"	25569	"	"						
25533	"	"	25570	"	"						
25534	"	"	25571	"	"						
25535	"	"	25572	"	"						
25536	"	"	25573	"	"						
25537	"	"	25574	"	"						
25538	"	"	25575	"	"						
25539	"	"	25576	"	"						
25540	"	"	25577	"	"						
25541	"	"	25578	"	"						
25542	"	"	25579	"	"						
25543	"	"	25580	"	"						
25544	"	"	25581	"	"						
25545	"	"	25582	"	"						
25546	"	"	25583	"	"						
25547	"	"	25584	"	"						
25548	"	"	25585	"	"						
25549	"	"	33150	Fde	1						

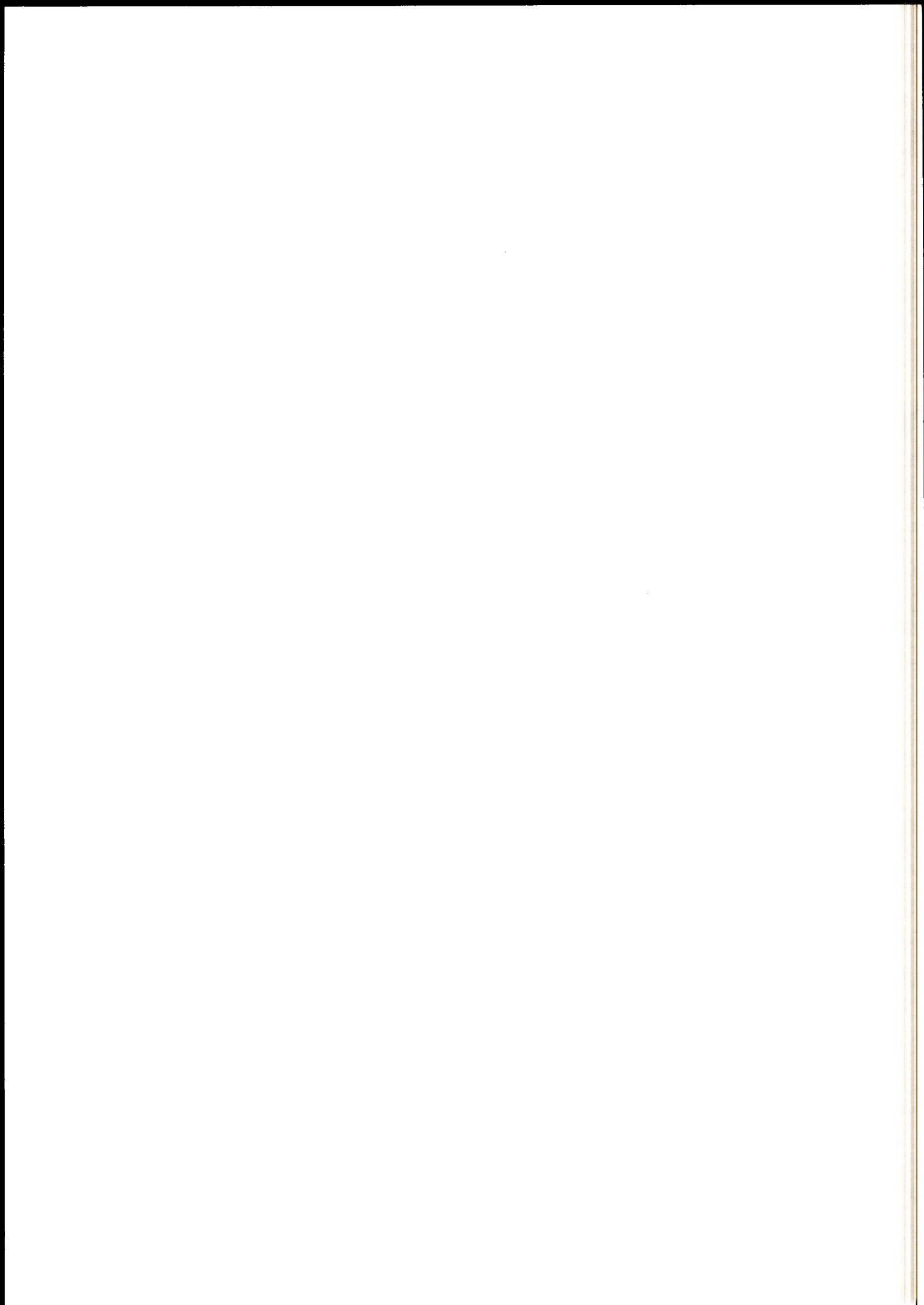

OVERSIKT OVER GJELDENDE BLAD I TRYKK NR. 751

pr. 1.7.66. Neste revisjon 1.7.67

Litra	Type	Vognnr. 1)	Dato for siste revisjon	Litra	Type	Vognnr. 1)	Dato for siste revisjon
Ao	2	100	1.7.66	Bo2c	5	952, 953	1.7.60
"	3	118	1.7.56	"	6	349, 18025	1.7.65
"	5	24001	1.7.64	"	7	504	1.7.66
WLAola	1	105, 18047	1.7.65	Bo2d	1	25001, 25019	1.7.64
WLAolb	1	21001, 21002	1.7.66	"	"	25020, 25030	1.7.64
"	2	21010, 21015	1.7.64	Bo2-3a	1	182	1.7.63
WLABola	1	629, 705	1.7.65	Bo3a	1	175, 788	1.7.66
WLABolb	1	207, 18075	1.7.65	"	"	814, 18129	1.7.62
WLABolc	1	21035, 21053	1.7.65	"	2	220, 18137	1.7.61
"	"	21054, 21082	1.7.66	Bo3b	1	80, 83	1.7.57
WLBola	1	199, 18116	1.7.66	"	2	84, 86	1.7.63
"	2	21007, 21009	1.7.64	"	3	87, 89	1.7.63
WLBolb	1	102, 18048	1.7.66	"	4	683, 684	1.7.61
WLBold	1	653	1.7.66	"	5	681, 682	1.7.61
"	2	21016, 21034	1.7.65	"	6	36, 37	1.7.64
"	3	21003, 21006	1.7.66	"	7	35	1.7.63
Ao2b	1	247, 18064	1.7.66	Bo3c	1	160, 558	1.7.65
Ao2c	1	248, 950	1.7.63	"	"	560, 18061	1.7.64
Ao2d	1	581	1.7.60	"	2	294, 18149	1.7.66
Ao3a	1	900, 990	1.7.66	"	3	899, 975	1.7.61
ABo2b	3	136, 18066	1.7.65	"	4	180, 18110	1.7.66
ABo2c	1	24101, 24103	1.7.66	Bo3d	1	450, 453	1.7.58
ABo2-3a	1	24104, 24123	1.7.65	"	2	18171, 18173	1.7.56
ABo3b	3	550, 18128	1.7.66	Bo3f	1	25503, 25525	1.7.66
ABZo2a	2	924	1.7.65	"	"	25526, 25530	1.7.66
Bo	1	19930	1.7.65	Bo3g	1	19922, 19929	1.7.57
Bo2a	1	164, 909	1.7.66	Bo3k	1	739	1.7.60
"	2	510, 959	1.7.63	"	2	741	1.7.62
Bo2b	1	476, 982	1.7.66	"	3	34	1.7.63
"	2	153, 344	1.7.66	Bo3l	1	25531, 25553	1.7.64
"	"	345, 18099	1.7.66	"	"	25554, 25562	1.7.64
"	3	224, 18145	1.7.66	"	2	25563, 25585	1.7.66
"	6	307, 508	1.7.66	Bo3m	1	306, 949	1.7.65
"	"	923, 956	1.7.66	"	2	308, 311	1.7.66
Bo2c	5	473, 951	1.7.62	Bo3p	1	25501, 25529	1.7.66

1) Hver enkelt side angis ved første og siste vognnummer.

OVERSIKT OVER GJELDENE BLAD I TRYKK NR. 751

pr. 1.7.66. Neste revisjon 1.7.67

Litra	Type	Vognnr. ¹⁾	Dato for siste revisjon	Litra	Type	Vognnr. ¹⁾	Dato for siste revisjon
Bo4b	3	966, 970	1.7.56	BFo2b	8	604, 626	1.7.64
"	4	78	1.7.66	BFo2c	1	94, 807	1.7.59
Bo4c	1	39, 610	1.7.66	"	2	188, 18015	1.7.66
Bo4d	2	18118, 18124	1.7.65	"	3	97, 120	1.7.64
"	5	233	1.7.61	"	"	121, 18017	1.7.64
BDFo2-7	1	963, 964	1.7.62	"	5	906, 724	1.7.56
"	2	18081, 18092	1.7.66	"	6	632, 784	1.7.60
BDFo2-11	2	917	1.7.56	BFo2d	1	21501, 21503	1.7.66
"	3	620, 18109	1.7.60	"	2	21504, 21514	1.7.66
"	6	18033, 18090	1.7.61	BFo2dk	1	21502	1.7.66
"	7	775	1.7.64	"	2	21507, 21512	1.7.66
BEo3a	1	772, 18140	1.7.66	BFo3a	2	67	1.7.64
BF	2	9001	1.7.56	BFo3b	3	9	1.7.65
BF2a	1	151	1.7.64	"	5	18169, 18170	1.7.56
"	2	686, 687	1.7.65	"	6	971, 972	1.7.64
BF2b	1	679, 695	1.7.57	BFo4b	6	18108	1.7.61
BF3	1	19900, 19921	1.7.64	BZo2a	1	135	1.7.65
"	2	19901	1.7.59	Do-39	1	787	1.7.64
"	3	19918, 19919	1.7.62	"	2	18107	1.7.65
BF3a	1	1001, 1002	1.7.58	DFo-16	1	433, 18009	1.7.64
"	2	697	1.7.60	"	2	434, 436	1.7.65
BF3b	1	237, 240	1.7.66	"	3	512, 513	1.7.64
"	2	547, 549	1.7.66	DFo-22	2	912, 18038	1.7.66
BFo2a	3	805	1.7.56	"	3	517	1.7.58
"	5	107, 204	1.7.62	"	4	432	1.7.66
"	7	627, 18080	1.7.61	"	5	875	1.7.56
BFo2ak	1	21515, 21524	1.7.66	"	6	21314, 21317	1.7.64
BFo2b	1	965	1.7.59	DFo-29	1	804, 808	1.7.56
"	2	778, 837	1.7.66	DFo-30	1	21308, 21313	1.7.65
"	3	514, 942	1.7.62	DFo-32	1	18010	1.7.66
"	4	545, 977	1.7.66	"	2	622	1.7.64
"	5	815, 18001	1.7.62	"	3	435	1.7.64
"	6	183, 781	1.7.66	"	4	21301, 21303	1.7.64
"	"	792, 18105	1.7.65	DFo-37	1	21304, 21321	1.7.66
"	7	624, 18130	1.7.65	DFZo-16	2	939	1.7.63

1) Hver enkelt side angis ved første og siste vognnummer.

OVERSIKT OVER GJELDENE BLAD I TRYKK NR. 751

pr. 1.7.66. Neste revisjon 1.7.67

Litra	Type	Vognnr. ¹⁾	Dato for siste revisjon	Litra	Type	Vognnr. ¹⁾	Dato for siste revisjon
Eo	2	119, 18011	1.7.64				
"	4	21251, 21256	1.7.66				
"	5	945, 980	1.7.66				
"	6	644, 646	1.7.64				
F	2	7001, 8002	1.7.65				
"	3	2007	1.7.61				
"	5	1007, 15011	1.7.65				
"	6	2011, 14002	1.7.66				
"	7	2019	1.7.66				
"	8	5009, 15015	1.7.66				
"	9	3009, 6025	1.7.65				
"	10	2022, 23102	1.7.66				
"	11	2025, 5023	1.7.65				
"	"	5024, 20774	1.7.66				
"	13	13022	1.7.58				
"	15	2023, 5010	1.7.59				
"	16	14952, 8487	1.7.56				
Fo	2	20058, 20063	1.7.65				
"	3	14013, 20066	1.7.65				
"	4	3045, 15019	1.7.64				
"	5	5678, 5679	1.7.59				
"	6	19951, 19952	1.7.65				
"	7	19953	1.7.66				
"	9	18091	1.7.59				
Fd	1	1025, 3043	1.7.66				
"	4	1023, 1024	1.7.56				
Fdo	1	20060, 20061	1.7.64				
Fde	1	33150	1.7.65				
"	2	19004	1.7.66				
Fdeo	1	19954, 19955	1.7.62				
FZo	2	5017, 17956	1.7.63				
Zo	1	16	1.7.56				
Zuo	3	166, 954	1.7.60				
"	4	31	1.7.62				

1) Hver enkelt side angis ved første og siste vognnummer.

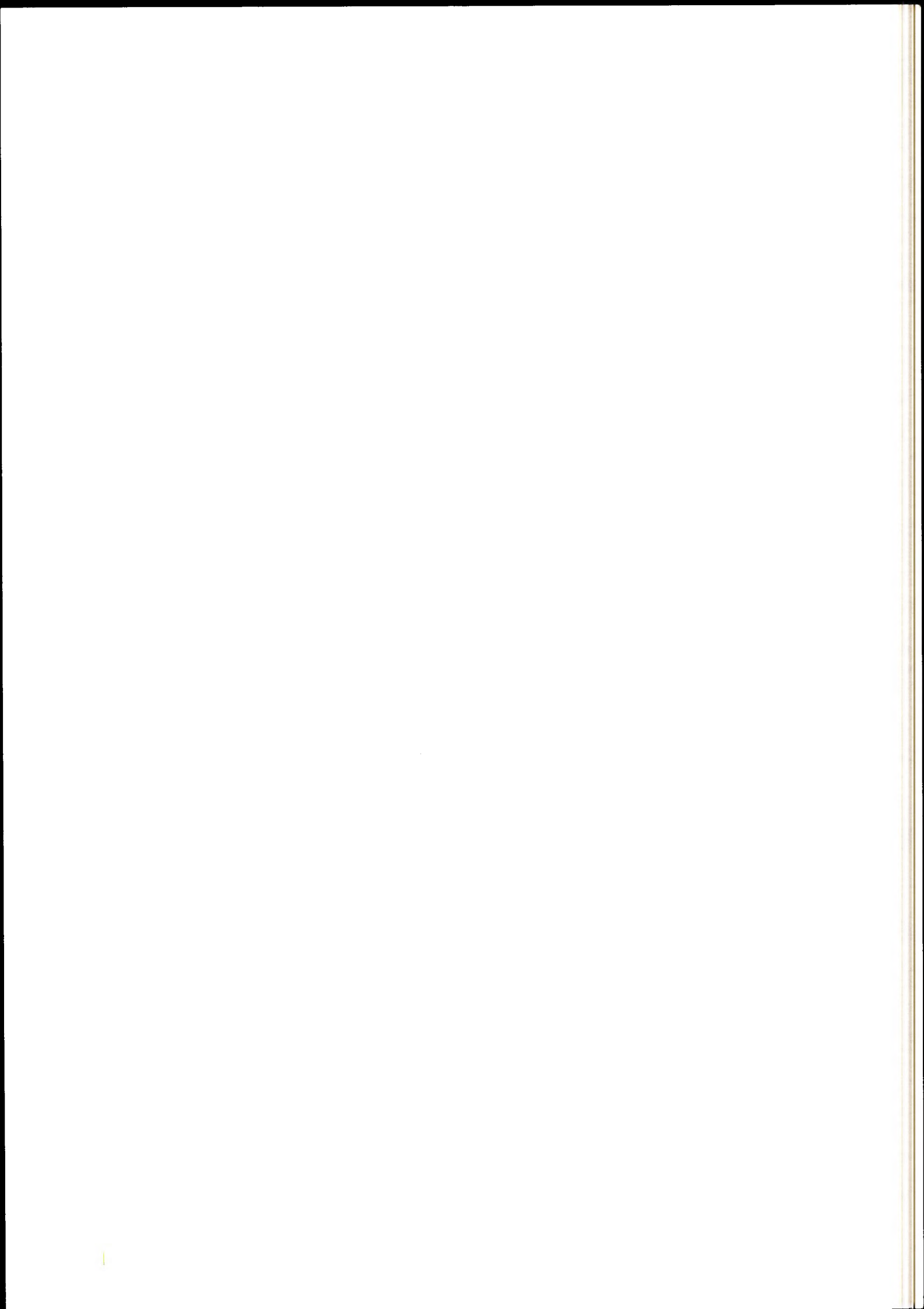

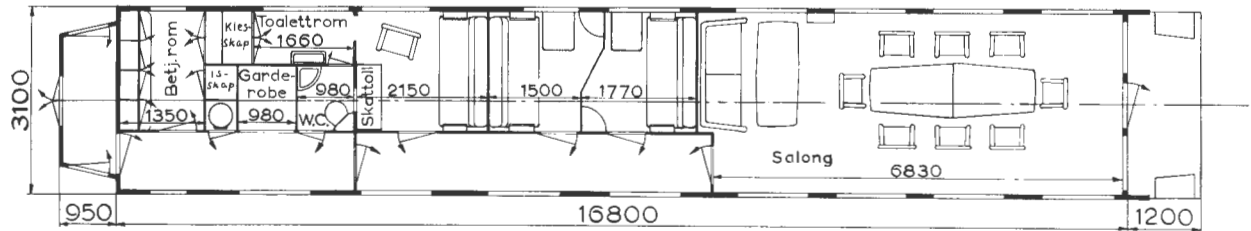
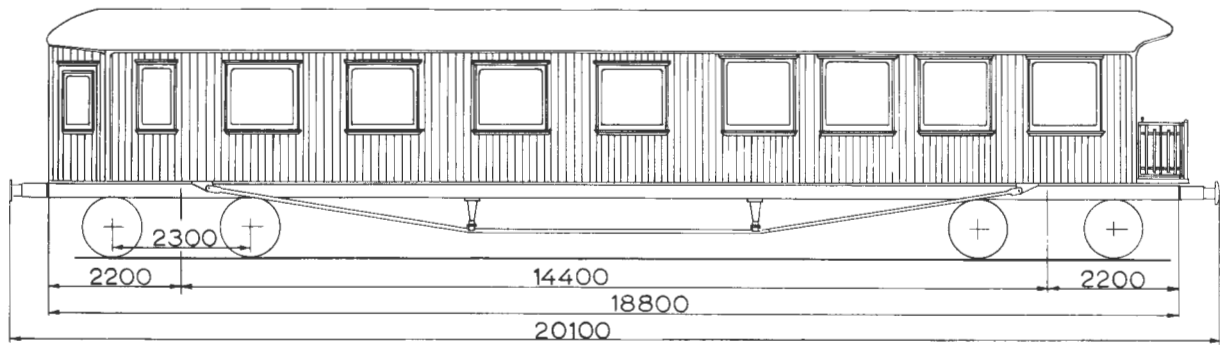

Oppr. hovedt. 2955 1)

Vogn nr.	Distriktsmerke	Fabrikant	Byggeår	Omtr. vognvekt i tonn	Sittepl. pr. vogn		Liggepl. pr. vogn		Grunnriss	El. varme i kW	Vognutstyr (se side 6)	Merknad
					1	2	1	2				
					klasse		klasse					
100	O	Skb	26	34,0	10		6				1H. 3. 5. 11. 28. 39a	

1) Forandr. etter Md.skisse nr.1232

Ao

TYPE 3

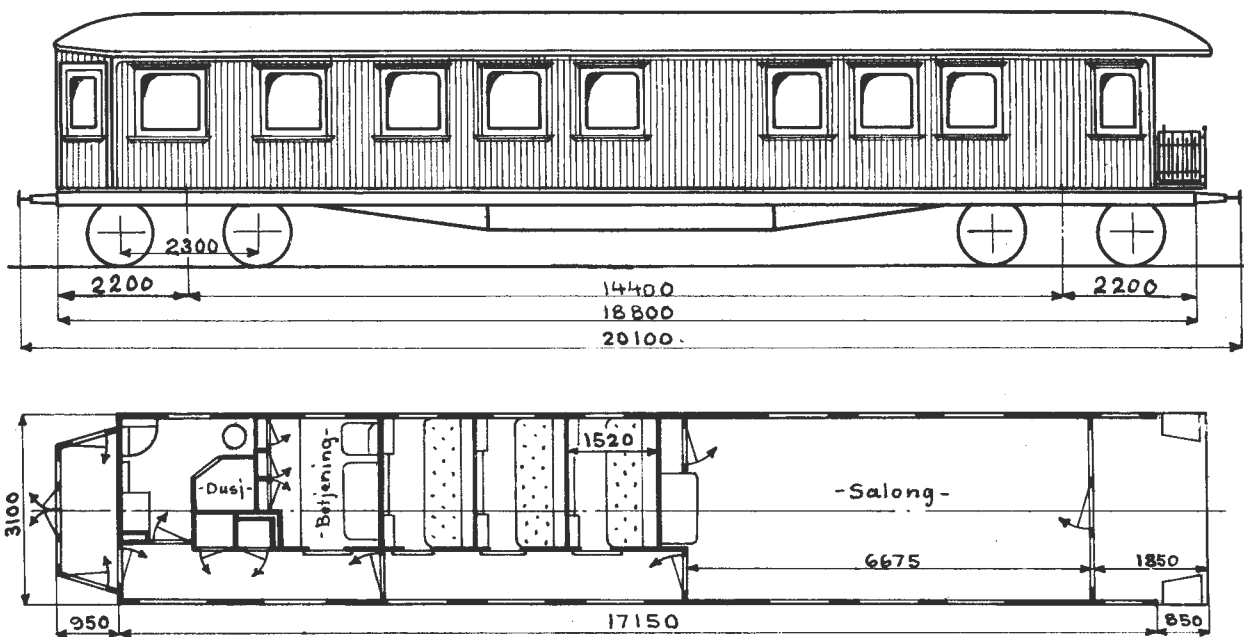

Hovedt. 2771

Vogn nr.	Distriktsmerke	Fabrikant	Byggeår	Omr. vognvekt i tonn	Sittepl. pr. vogn				Liggepl. pr. vogn		Grunnriss	El. varme i kW	Vognutstyr (se side 6)	Merknad
					1		2		1	2				
					klasse		klasse		klasse					
118	0	Skb	23	36,0					6			1KK.3.5.11.28.35.39a		

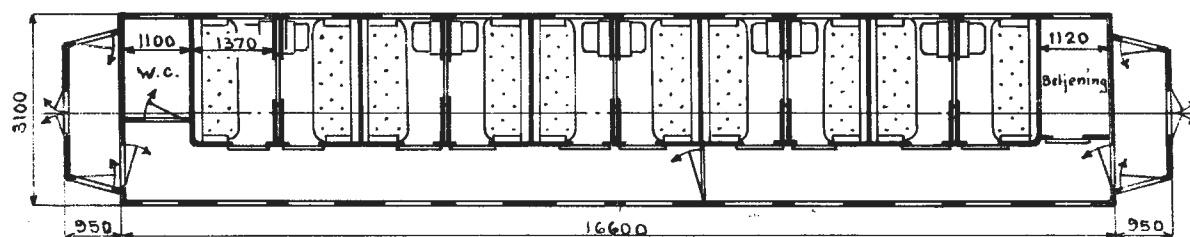
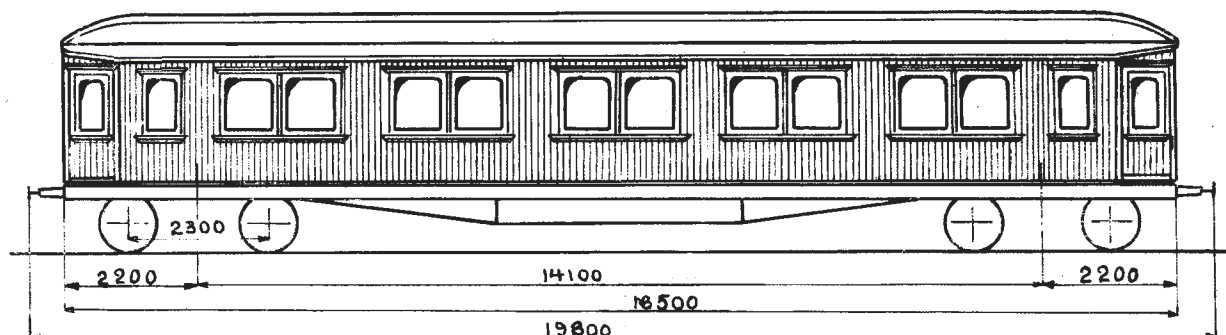

Hovedt. 2059
2222

Vogn nr.	Distriktsmerke	Fabrikant	Byggeår	Omtr. vognvekt i tonn	Sittepl. pr. vogn				Liggepl. pr. vogn	Grunnriss	El. varme i kW	Vognutstyr (se side 6)	Merknad
					1		2						
					klasse	klasse	klasse	klasse					
105	0	Skb	13	35,5	30			20			1H.3.5.11.28.35.39a	1) 2)	
210	"	Kok	21	36,0	"			"			1KK.3.5.11.28.39a		
986	B	Skb	12	34,5	"			"			1H.3.5.11.28.39a	1)	
995	"	"	19	35,0	"			"			1H.3.5.11.28.39a	2)	
18047	T	"	17	37,0	"			"			1H.3.5.11.28.39a		

1) Hovedt. 2059

2) Dør mellom kupéer er blindet

Trykk nr. 751 1.7.65

WLAo1b

TYPE 1
Stålvogner

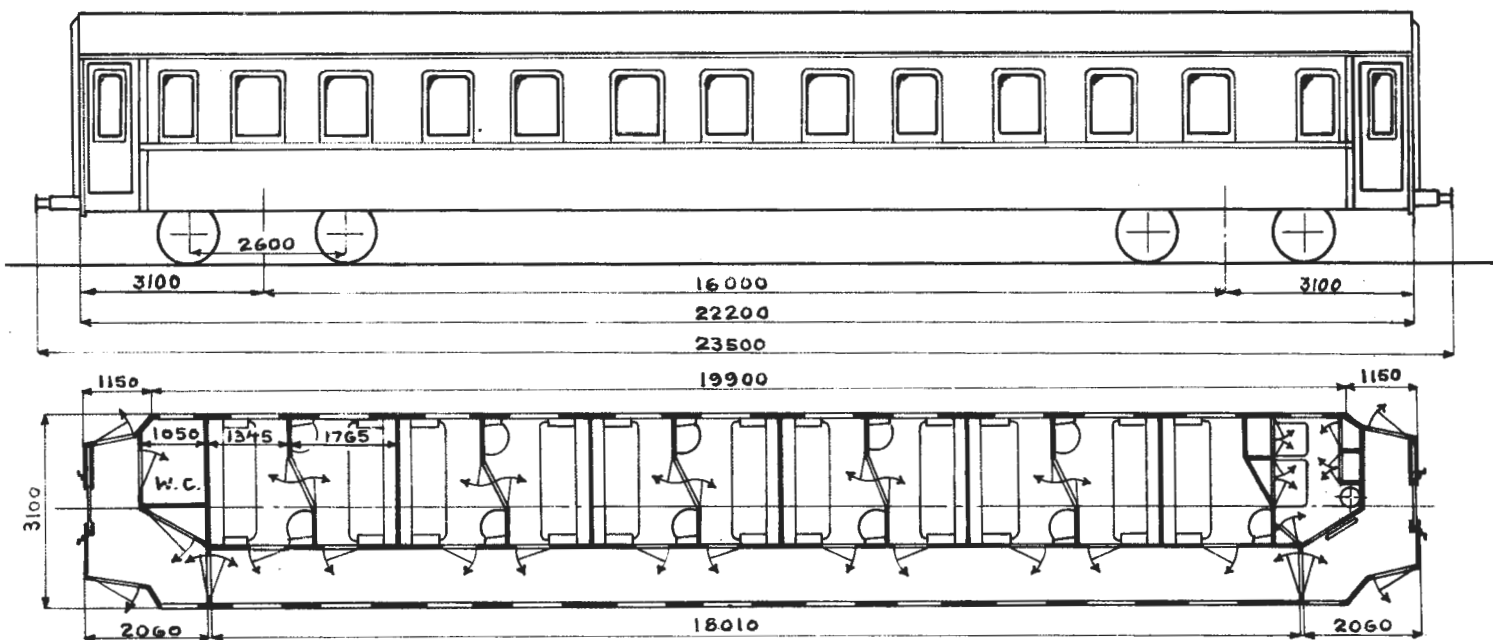

Hovedt. 4300

Vogn nr.	Distriktsmerke	Fabrikant	Byggeår	Omr. vognvekt i tonn	Syttepl. Liggepl. pr. vogn				Grunnriss	El. varme i kW	Vognutstyr (se side 6)	Merknad
					1		2					
					klasse	klasse	klasse	klasse				
21001	0	Str	39	40,0	33	22			45	1KE.3.5a.11.28.39b		
21002	"	"	"	39,0	"	"			"	1KE.3.5a.11.28.39b		

Vogn nr.	Distriktsmerke	Fabrikant	Byggeår	Omtr. vognvekt i tonn	Sittepl. pr. vogn		Liggepl. pr. vogn		Grunnriss	El. varme i kW	Vognutstyr (se side 6)	Merknad
					1	2	1	2				
					klasse		klasse					
21054	Skb	61	42,0	33 ¹⁾	44 ¹⁾	22 ¹⁾	33 ¹⁾	47	1KE.3.4a.12.28.39a			
21055	"	62	"	"	"	"	"	"	1KE.3.4a.12.28.39a			
21056	"	"	"	"	"	"	"	"	1KE.3.4a.12.28.39a			
21057	Str	63	41,0	"	"	"	"	"	1KE.3.4a.12.28.39a			
21058	"	"	"	"	"	"	"	"	1KE.3.4a.12.28.39a			
21059	"	"	"	"	"	"	"	"	1KE.3.4a.12.28.39a			
21060	"	"	"	"	"	"	"	"	1KE.3.4a.12.28.39a			
21061	"	"	"	"	"	"	"	"	1KE.3.4a.12.28.39a			
21062	"	"	"	"	"	"	"	"	1KE.3.4a.12.28.39a			
21063	"	"	"	"	"	"	"	"	1KE.3.4a.12.28.39a			
21064	"	"	"	"	"	"	"	"	1KE.3.4a.12.28.39a			
21065	"	"	"	"	"	"	"	"	1KE.3.4a.12.28.39a			
21066	"	"	"	"	"	"	"	"	1KE.3.4a.12.28.39a			
21067	"	65	39,5	"	"	"	"	"	1KEs.3.4a.12.28.39a			
21068	"	"	"	"	"	"	"	"	1KEs.3.4a.12.28.39a			
21069	"	"	"	"	"	"	"	"	1KEs.3.4a.12.28.39a			
21070	"	"	"	"	"	"	"	"	1KEs.3.4a.12.28.39a			
21071	"	"	"	"	"	"	"	"	1KEs.3.4a.12.28.39a			
21072	"	"	"	"	"	"	"	"	1KEs.3.4a.12.28.39a			
21073	"	"	"	"	"	"	"	"	1KEs.3.4a.12.28.39a			
21074	"	"	"	"	"	"	"	"	1KEs.3.4a.12.28.39a			
21075	"	"	"	"	"	"	"	"	1KEs.3.4a.12.28.39a			
21076	"	"	"	"	"	"	"	"	1KEs.3.4a.12.28.39a			
21077	"	"	"	"	"	"	"	"	1KEs.3.4a.12.28.39a			
21078	"	"	"	"	"	"	"	"	1KEs.3.4a.12.28.39a			
21079	"	"	"	"	"	"	"	"	1KEs.3.4a.12.28.39a			
21080	"	"	"	"	"	"	"	"	1KEs.3.4a.12.28.39a			
21081	"	"	"	"	"	"	"	"	1KEs.3.4a.12.28.39a			
21082	"	"	"	"	"	"	"	"	1KEs.3.4a.12.28.39a			

1) Køyene er regulerbare slik at den enkelte kupé kan nyttes enten som 2. kl., 1. kl. eller single.

WLBo1a

TYPE 1

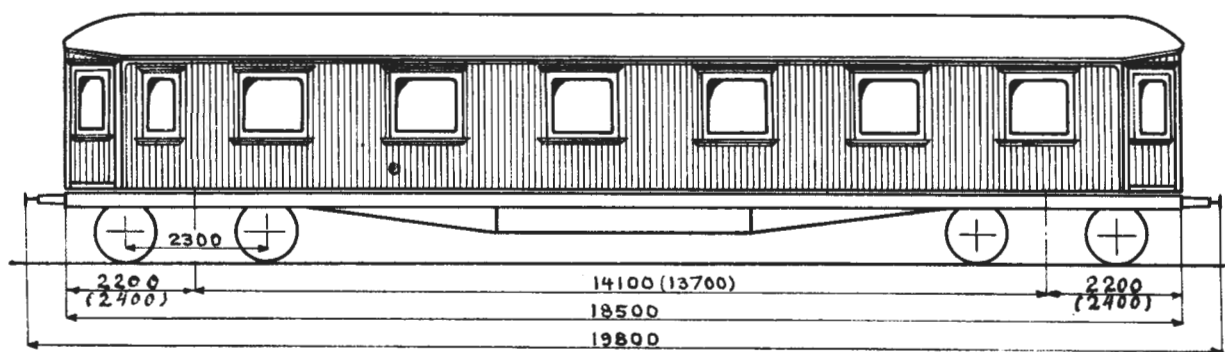

Mål i () for vogner efter tegn. 3140.

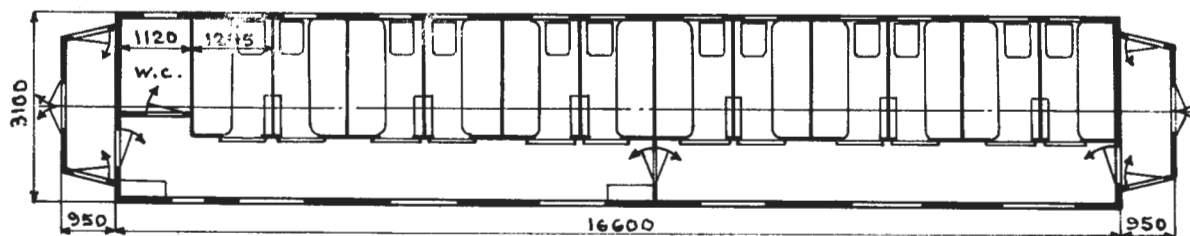

1304
Hovedt. 2249
3140

Vogn nr	Distriktsmerke	Fabrikant	Byggear	Omr. vognvekt i tonn	Sittepl. pr. vogn		Liggepl. pr. vogn		Grunnriss	El. varme i kW	Vognutstyr (se side 6)	Merknad
					1	2	1	2				
					klasse		klasse					
199	O	Str	30	37,0		48		36			1KK.3.5.11.28.39a	3)
200	"	"	"	38,0		"		"			1H.3.5.11.28.39a	3)
18005	T	"	14	36,0		"		"			1H.3.5.11.28.39a	1)
18056	D	"	20	38,0		"		"			1H.3.5.11.28.39a	2) 4)
18102	T	Kok	21	36,5		"		"			1H.3.5.11.28.39a	2)
18103	"	"	"	"		"		"			1H.3.5.11.28.39a	2)
18116	B	Skb	25	36,0		"		"			1H.3.5.11.28.39a	2)

- 1) Hovedt. 1304
2) " 2249
3) " 3140
4) Plattf.sidedører slår ut

Trykk nr. 751 1.7.66

WLBo1a

TYPE 2

Stålvogner

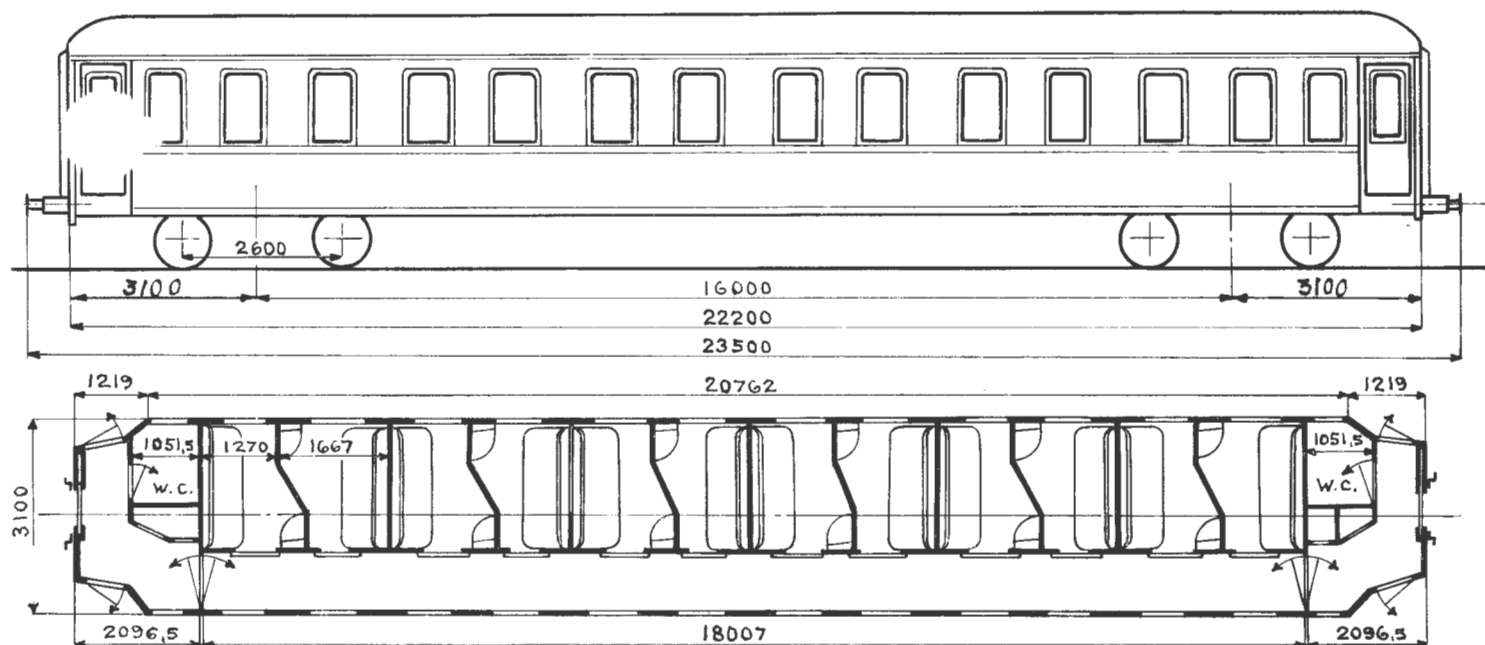

Hovedt. 4700

Vogn nr	Distriktsmerke	Fabrikant	Byggeår	Omr. vognvekt i tonn	Sittepl. pr. vogn		Liggepl. pr. vogn		Grunnriss	El. varme i kW	Vognutstyr (se side 6)	Merknad
					1	2	1	2				
					klasse		klasse					
21007	0	Skb	41	38,0		48		36		45	1H.3.5a.11.28.39b	
21008	"	"	"	40,0		"		"		"	1H.3.5a.11.28.39b	
21009	"	"	"	39,0		"		"		"	1H.3.5a.12.28.39b	

WLBo 1b

TYPE 1

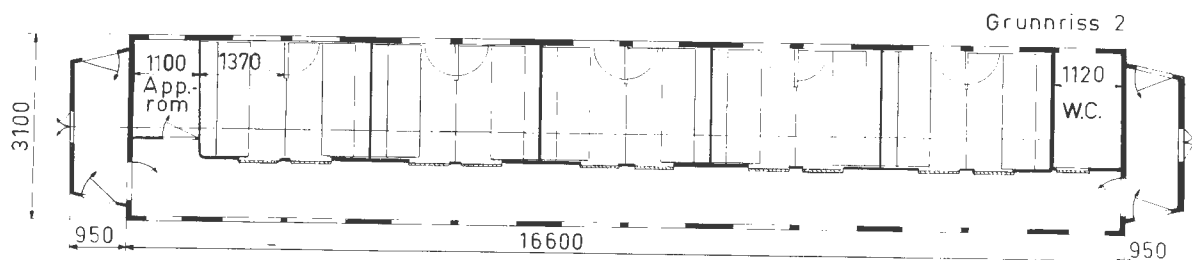
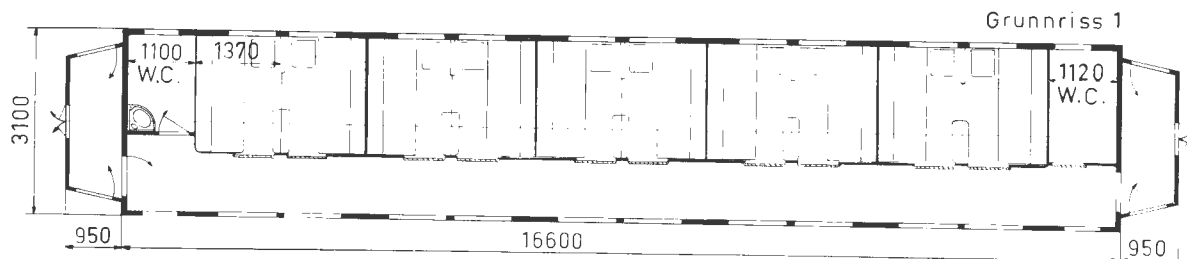
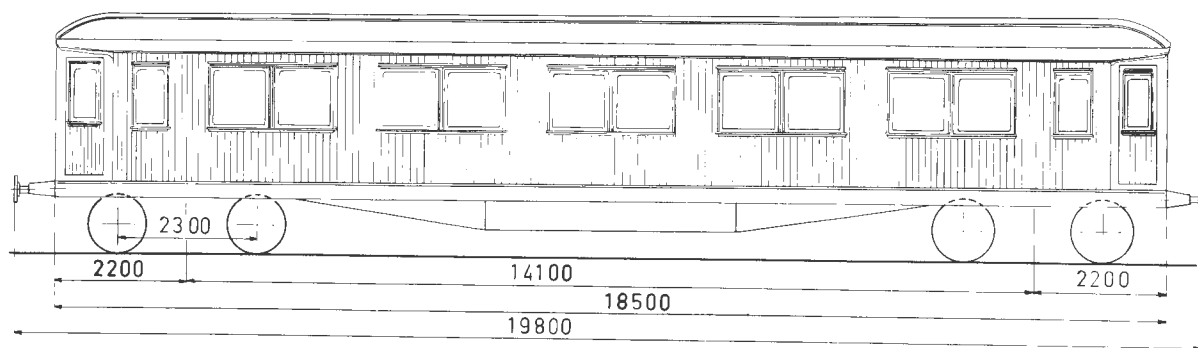

Oppr. hovedt. 2059¹⁾
2222¹⁾

Vogn nr.	Distriktsmerke	Fabrikant	Byggeår	Omr. vognvekt i tonn.	Sittepl. pr. vogn		Liggepl. pr. vogn		Grunnriss	El. varme i kW	Vognutstyr (se side 6)	Merknad
					1	2	1	2				
					klasse		klasse					
102	D	Kok	21	36,5		40		30	2		1KK.3.5.11.28.39a	
103	O	Skb	13	37,0		"		"	"		1H.3.5.11.28.39a	2) 3)
202	"	Kok	21	37,5		"		"	"		1H.3.5.11.28.39a	
208	"	Skb	12	35,5		"		"	1		1KK.3.5.11.28.35.39a	2)
991	B	"	13	36,5		"		"	2		1H.3.5.11.28.39a	2)
18003	O	"	14	"		"		"	1		1H.3.5.11.28.39a	2)
18048	T	"	17	37,5		"		"	"		1H.3.5.11.28.39a	2)

- 1) Forandr. etter tegn. 4384
- 2) Oppr. hovedt. 2059
- 3) Plattform sidedører slår u

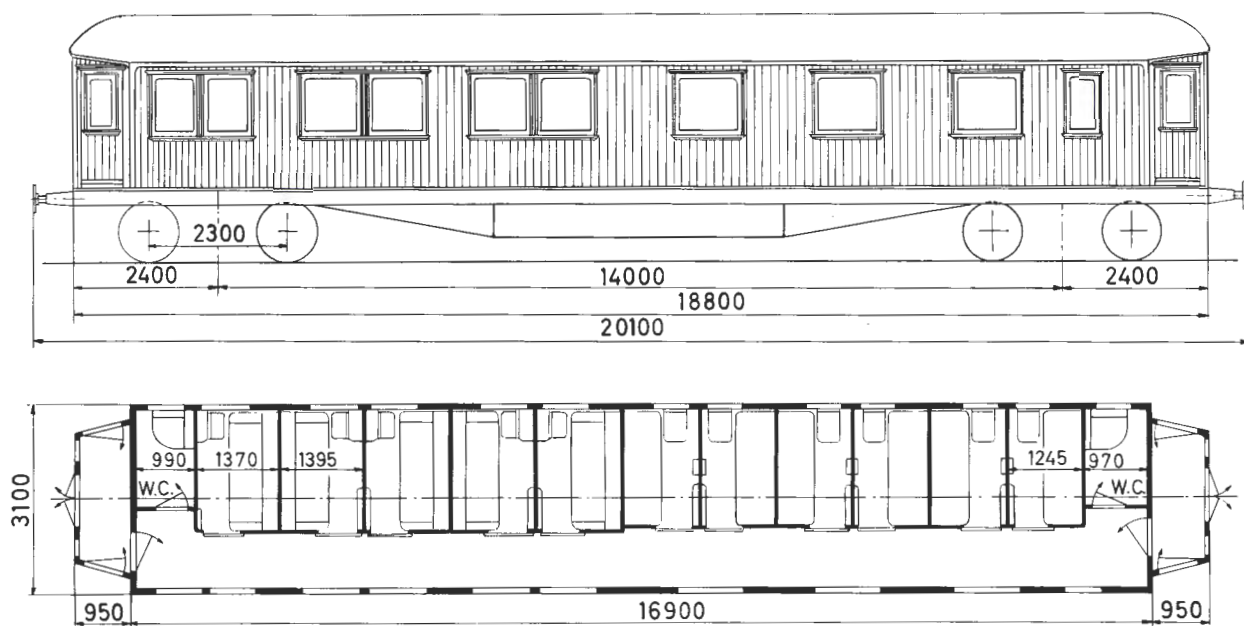

Oppr. hovedt. 3151

Vogn nr.	Distriktsmerke	Fabrikant	Byggeår	Omr.vognvekt i tonn	Sittepl. pr.vogn		Liggepl. pr.vogn		Grunnriss	El.varme i kW	Vognutstyr (se side 6)	Merknad
					1	2	1	2				
					klasse	klasse	klasse	klasse				
653	D	Skb	29	36,0		44		33			1H. 3. 5. 11. 28. 39a	

WL Bold

TYPE 2

Stålvogner

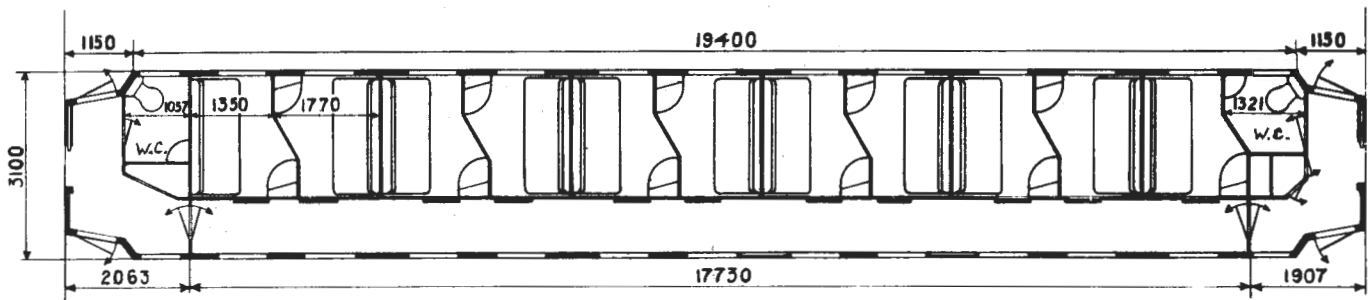
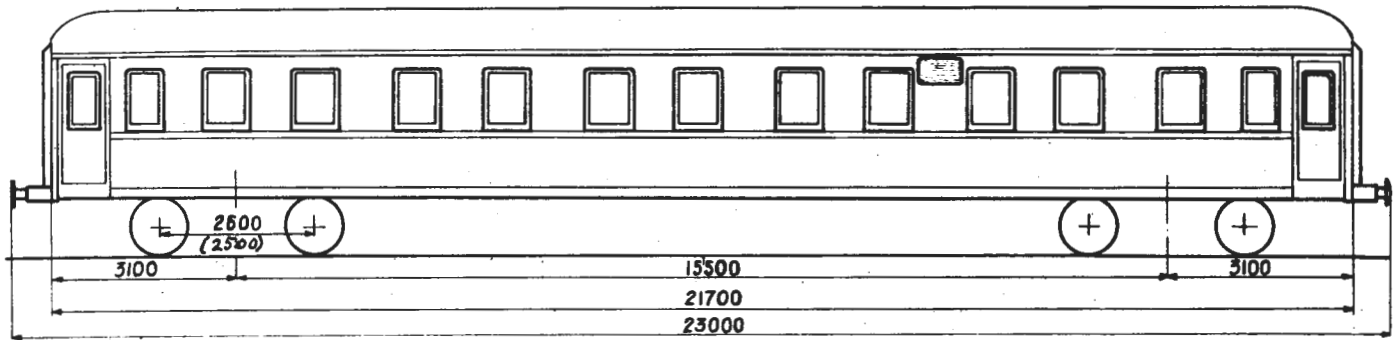

Hovedt. 5836

Vogn nr	Distriktsmerke	Fabrikant	Byggeår	Omtr. vognvekt i tonn	Sittepl. pr. vogn		Liggepl. pr. vogn		Grunnriss	El. varme i kW	Vognutstyr (se side 6)	Merknad
					1	2	1	2				
					klasse		klasse					
21016	D	Scd	52	39,5		44		33	51	1KE.3.4a.12.28.39a	1)	
21017	"	"	"	41,0		"		"	"	1KE.3.4a.12.28.39a	1)	
21018	"	"	"	39,5		"		"	"	1KE.3.4a.12.28.39a	1)	
21019	"	"	51	40,0		"		"	"	1KE.3.4a.12.28.39a		
21020	"	"	"	41,5		"		"	"	1KE.3.4a.12.28.39a		
21021	"	"	"	41,0		"		"	"	1KE.3.4a.12.28.39a		
21022	"	"	"	40,0		"		"	"	1KE.3.4a.12.28.39a		
21023	O	"	"	39,5		"		"	"	1KE.3.4a.12.28.39a		
21024	"	"	"	40,5		"		"	"	1KE.3.4a.12.28.39a		
21025	B	Skb	56	"		"		"	30	1KE.3.5.11.28.39a		
21026	"	"	"	"		"		"	"	1KE.3.5.11.28.39a		
21027	"	"	"	"		"		"	"	1KE.3.5.11.28.39a		
21028	"	"	57	"		"		"	"	1KE.3.5.11.28.39a		
21029	O	"	"	"		"		"	"	1KE.3.5.11.28.39a		
21030	T	"	"	"		"		"	"	1KE.3.5.11.28.39a		
21031	"	"	"	"		"		"	"	1KE.3.5.11.28.39a		
21032	O	"	56	39,5		"		"	40	1KE.3.12.28.39a	1)	
21033	"	"	"	40,0		"		"	"	1KE.3.12.28.39a	1)	
21034	"	"	"	"		"		"	"	1KE.3.12.28.39a	1)	

Mål i () gjelder vg. nr. 21018-21020, 21022-21024, 21032 og 21034

1) Oppr. hovedt. 5838

Trykk nr. 751 1.7.65

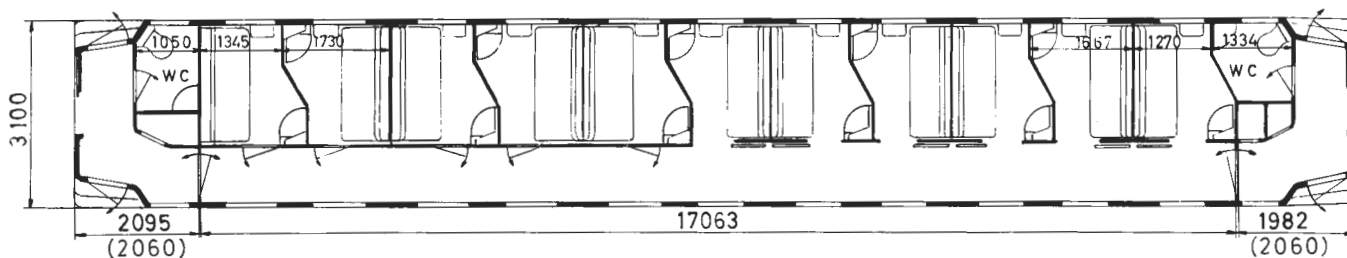
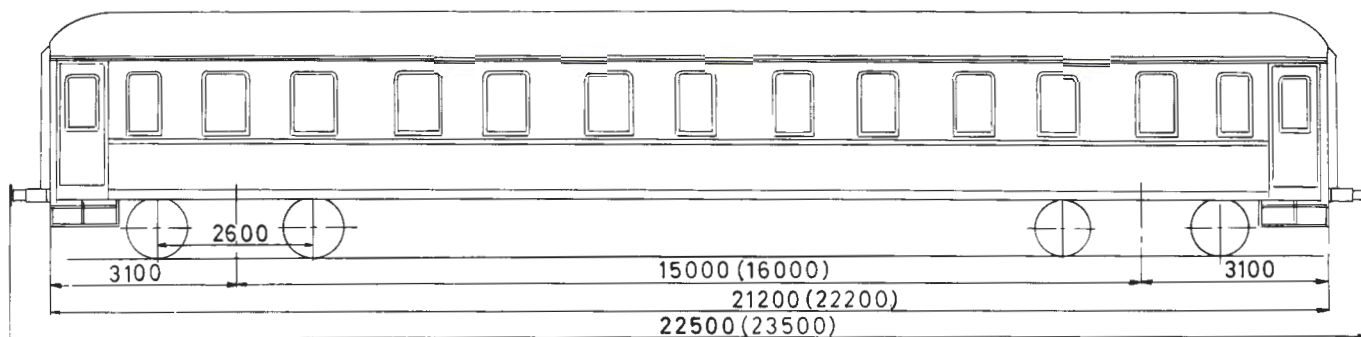

Oppr. hovedt. 4725

Vogn nr.	Distriktsmerke	Fabrikant	Byggeår	Omr. vognvekt i tonn	Sittepl. pr. vogn		Liggepl. pr. vogn		Grunnriss	El. varme i kW	Vognutstyr (se side 6)	Merknad
					1	2	1	2				
					klasse		klasse					
21003	O	Str	39	40,5		44		33			1 KE.3.5a.11.28.39b	1)
21004	"	Skb	40	37,0		"		"		1 KE.3.5a.11.28.39b		
21005	"	"	"	39,0		"		"		1 KE.3.5a.11.28.39b		
21006	"	"	"	37,0		"		"		1 KE.3.5a.11.28.39b		

Mål i () gjelder vg.nr. 21003

1) Oppr. hovedt 4300

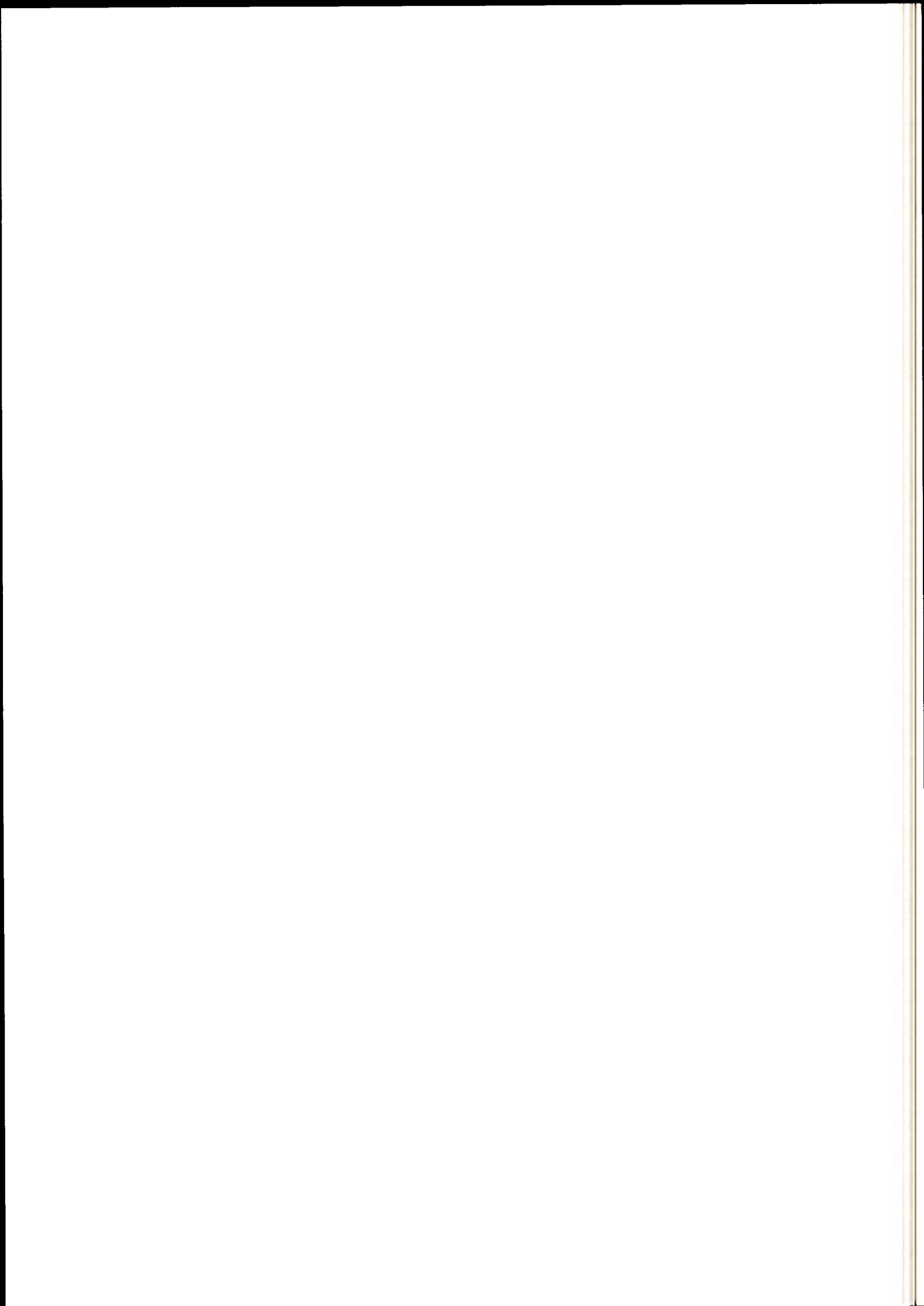

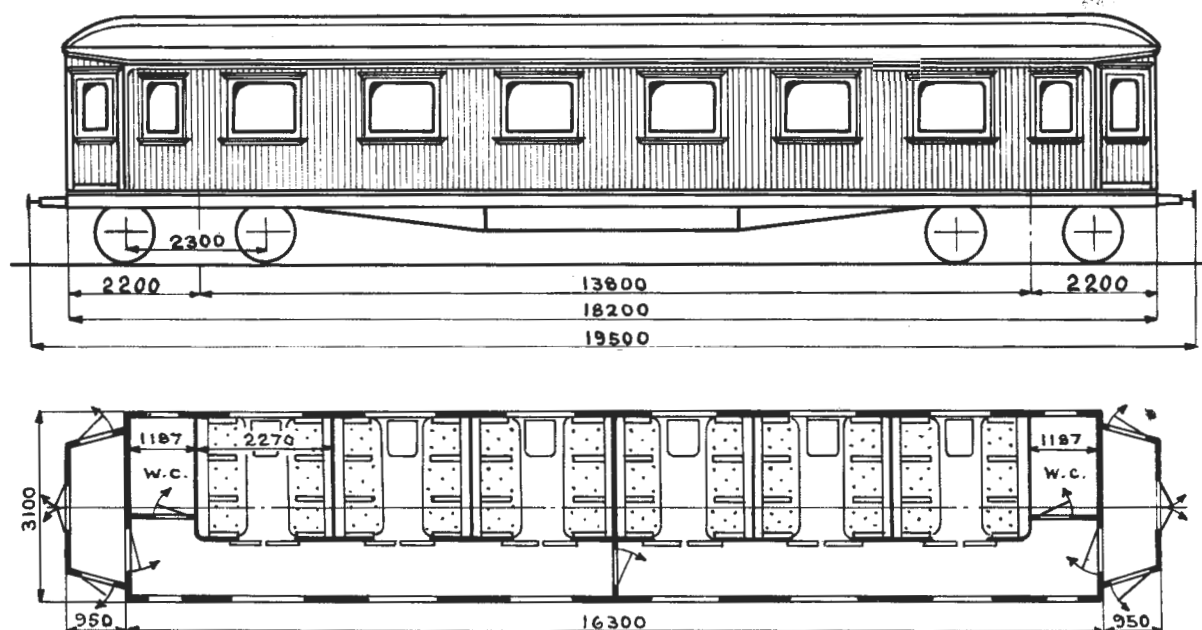

Hovedt. 1844
2026

Vogn nr.	Distriktsmerke	Fabrikant	Byggeår	Omr. vognvekt i tonn	Sittepl. 1.klasse	Grunnriss	El. varme i kW	Vognutstyr (se side 6)	Merknad
247	O	Str	13	34,5	36			1KK.3.5.11.28.35.39a	1)
209	"	"	15	"	"			1KK.3.5.11.28.35.39a	2)
18035	T	Skb	19	33,5	"			1H.3.5.11.28.39a	2)
18064	D	"	21	34,0	"			1H.3.5.11.28.39a	2)

1) Hovedt. 2026
2) " 1844

Ao2c

TYPE 1

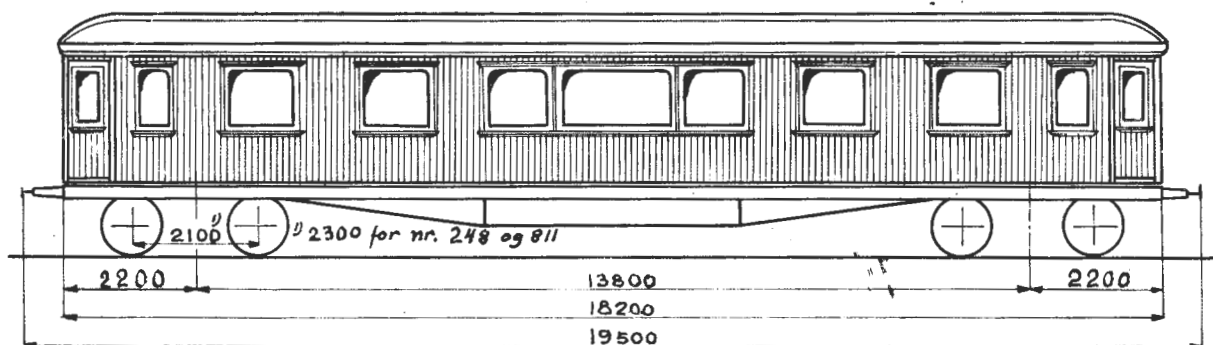

Grunnriss 1

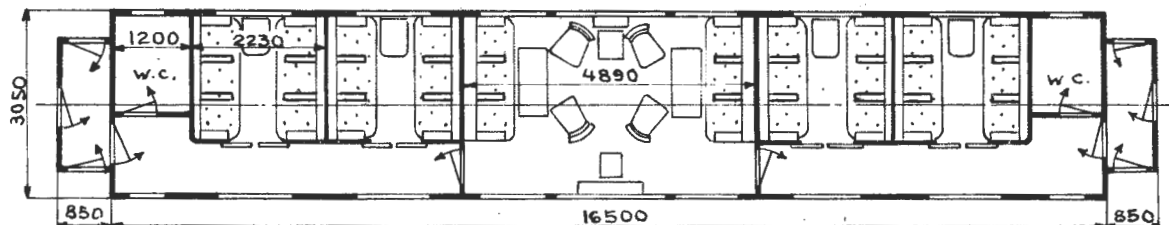

Grunnriss 2

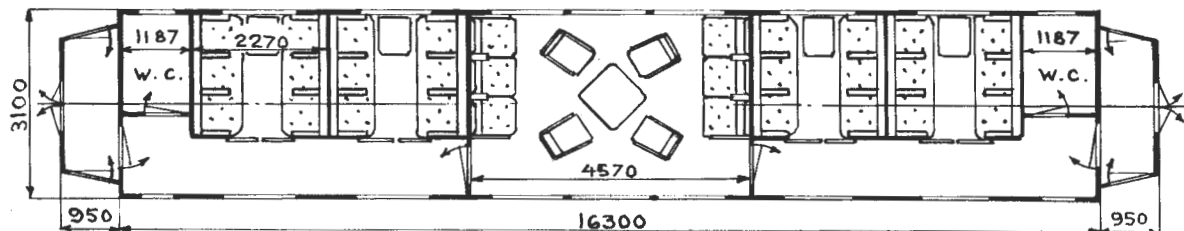

Hovedt. gr.riss 1: 1134
Oppr. hovedt. gr.riss 2: 2026²⁾

Vogn nr.	Distriktsmerke	Fabrikant	Byggeår	Omr. vognvekt i tonn	Sittepl. 1.klasse	Grunnriss	El. varme i kW	Vognutstyr (se side 6)	Merknad
248	O	Str	13	34,0	34 ³⁾	2		1H.3.5.11.28.35.39a	4)
811	T	Skb	10	29,5	"	1		1H.3.5.11.28.39a	
950	B	"	"	"	"	"		1H.3.5.11.28.39a	

2) Forandr. etter tegn. O.d. 3677

3) Herav 10 i salong

4) Dobbelte plattformendedører

Trykk nr. 751 1.7.63

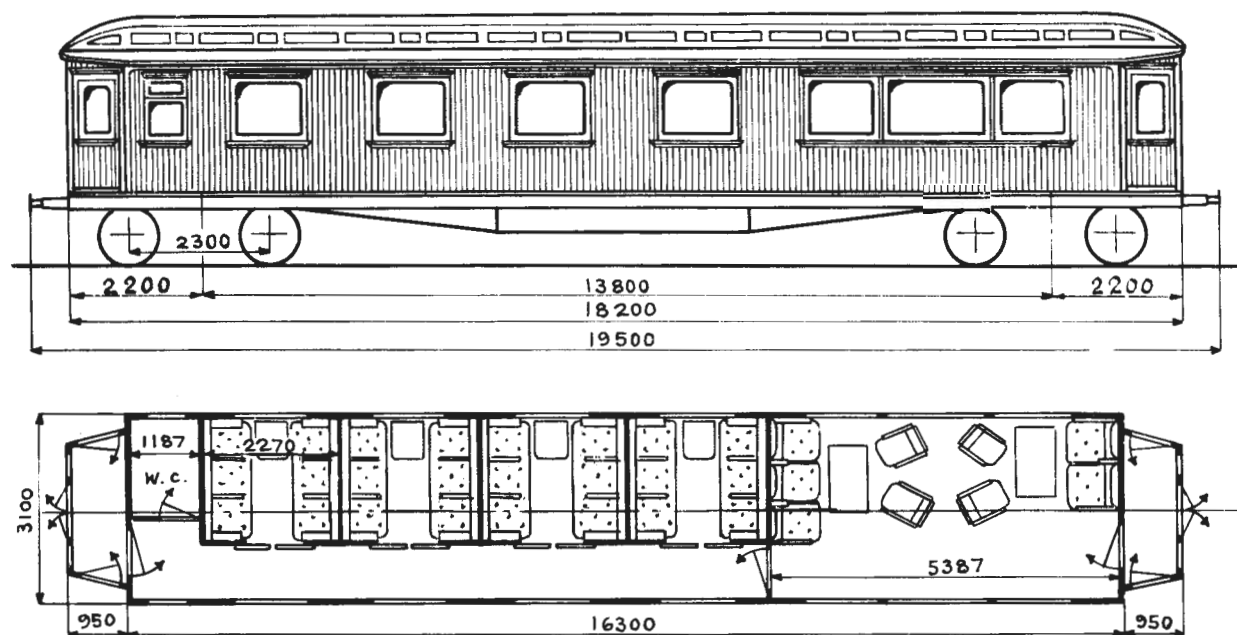

Oppr. hovedt. 1844

Vogn nr.	Distriktsmerke	Fabrikant	Byggeår	Omr. vognvekt i tonn	Sittep. 1.klasse	Grunnriss	El. varme i kW	Vognutstyr (se side 6)	Merknad
581	D	Skb	21	34,0	33 ¹⁾			1H.3.5.11.28.35.39a	

1) Herav 9 i salong

Ao3a

TYPE 1

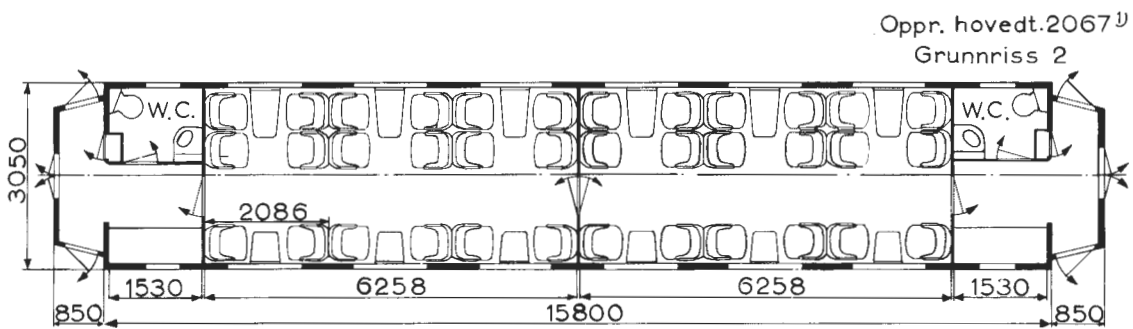
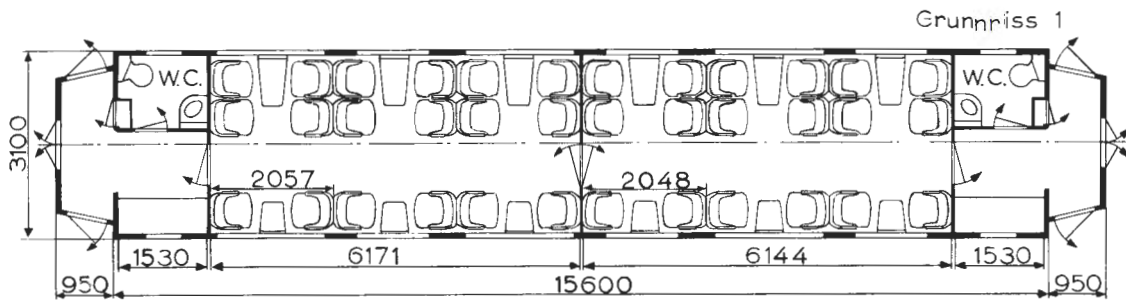
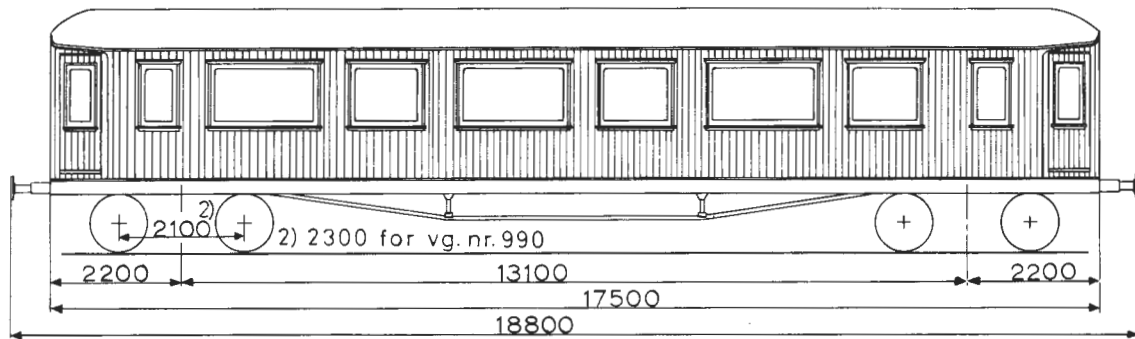

Oppr. hovedt. 993¹⁾

Vogn nr.	Distriktsmerke	Fabrikant	Byggear	Omr. vognvekt i tonn	Sittepl. 1.klasse	Grunnriss	El. varme i kW	Vognutstyr (se side 6)	Merknad
900	O	Str	09	29,5	36	2		1H, 3, 5, 11, 28, 39a	
690	"	"	10	29,0	"	"		1H, 3, 5, 11, 28, 39a	
946	B	"	"	"	"	"		1H, 3, 5, 11, 28, 39a	
947	"	"	"	28,0	"	"		1H, 3, 5, 11, 28, 39a	
989	"	Skb	12	28,5	"	1		1H, 3, 5, 11, 28, 39a	
990	"	"	"	"	"	"		1H, 3, 5, 11, 28, 39a	

¹⁾ Forandr. etter tegn. 7072

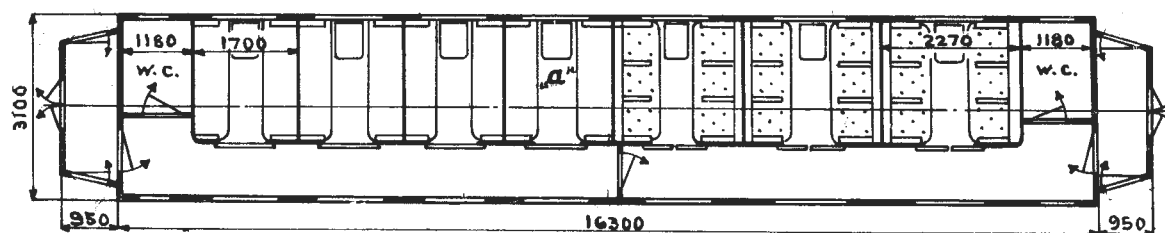
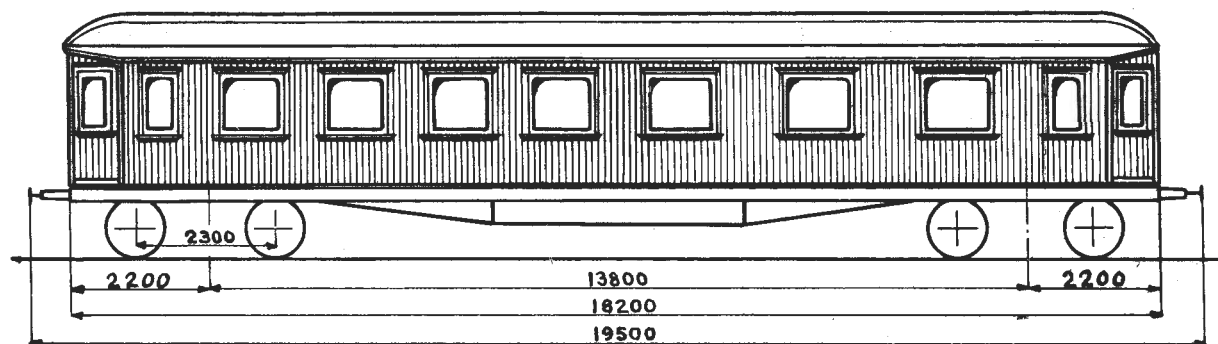

Hovedt. 1840
2089

Vogn nr.	Distriktsmerke	Fabrikant	Byggeår	Omr. vognvekt i tonn	Sittepl. pr. vogn		Grunnriss	El. varme i kW	Vognutstyr (se side 6)	Merknad
					1	2				
136	0	Skb	15	34,0	18	32			1H.3.5.11.28.35.39a	
137	"	"	"	33,5	"	"			1H.3.5.11.28.39a	
139	"	Str	18	"	"	"			1KK.3.5.11.28.39a	
348	"	"	17	34,0	"	"			1H.3.5.11.28.39a	
352	"	"	18	32,5	"	"			1H.3.11.28.39a	1)
18002	T	"	13	33,0	"	"			1H.3.5.11.28.39a	2) 3)
18018	"	Skb	15	"	"	"			1H.3.5.11.28.39a	1)
18024	D	"	16	"	"	"			1H.3.5.11.28.39a	
18065	"	"	21	"	"	"			1H.3.5.11.28.39a	
18066	"	"	"	"	"	"			1H.3.5.11.28.39a	

- 1) Plattformsidedører slår ut
- 2) Sykekupé "a"
- 3) Hovedt. 2089

A Bo 2c

TYPE 1
Stålvogner

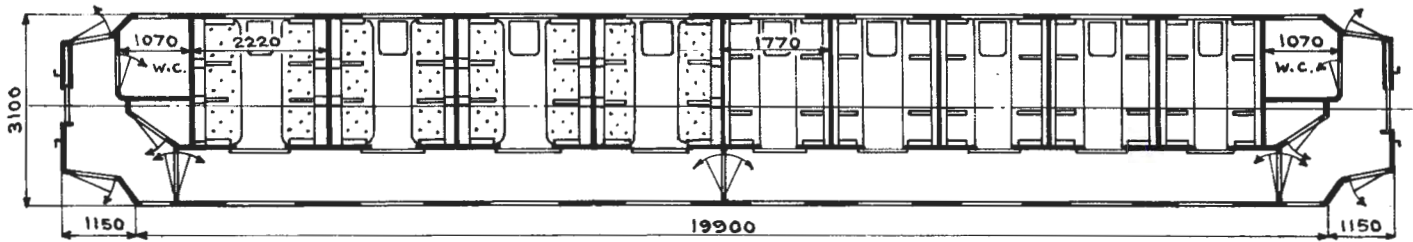
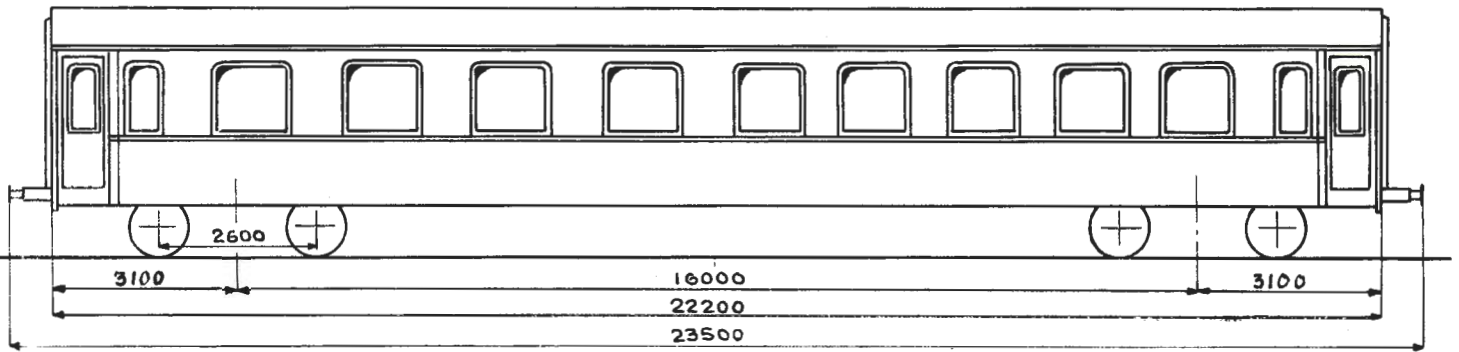

Hovedt. 3600

Vogn nr.	Distriktsmerke	Fabrikant	Byggeår	Omtr. vognvekt i tonn	Sitrepl. pr. vogn		Grunnriss	El. varme i kW	Vognutstyr (se side 6)	Merknad
					1	2				
24101	0	Str	35	39,0	24	40	28	1KEs.3.5.11.28.39a		
24102	"	"	"	"	"	"	"	1KE.3.5.11.28.39a		
24103	"	Skb	"	"	"	"	"	1KEs.3.5.11.28.39a		

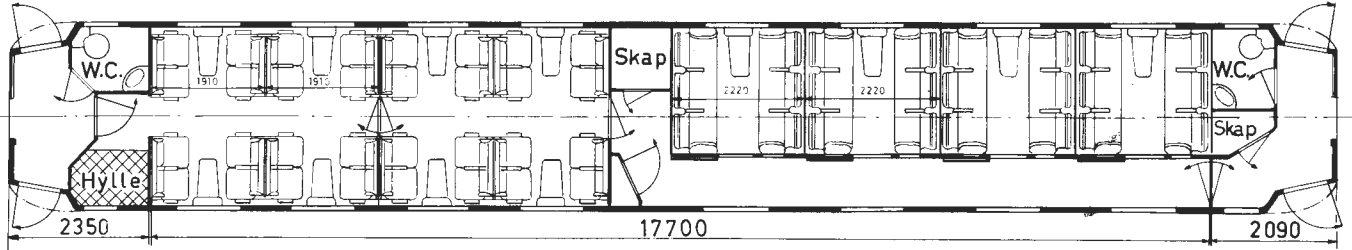
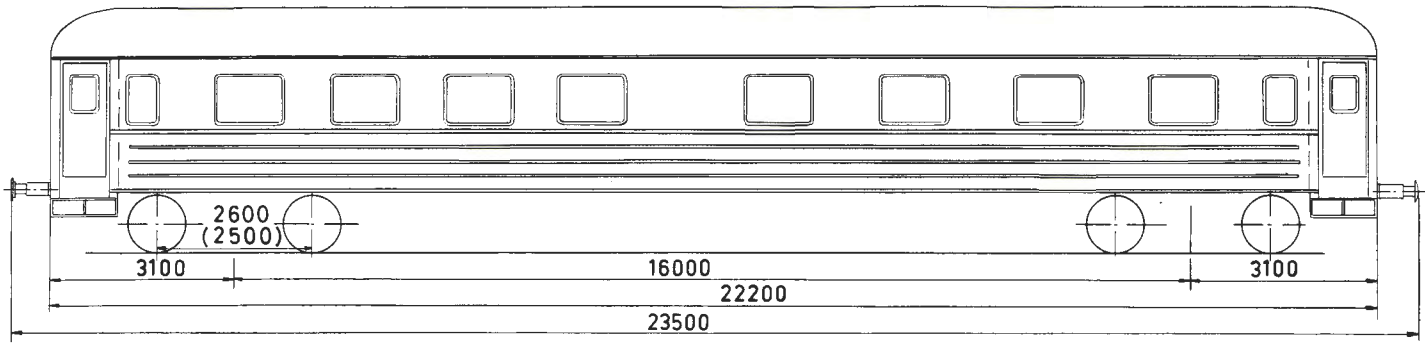

Hovedt. 10600

Vogn nr.	Fabrikant	Bygge år	Omtr. vognvekt i tonn	Sittepl. pr. vogn		Grunnriss	El. varme i kW	Vognutstyr (se side 6)	Merknad
				1	2				
24104	Str	60	38,0	24	32		36	1KE.3.4a.5.11.28.39a	
24105	"	"	"	"	"		"	1KE.3.4a.5.11.28.39a	
24106	"	"	"	"	"		"	1KE.3.4a.5.11.28.39a	
24107	"	"	"	"	"		"	1KE.3.4a.5.11.28.39a	
24108	"	"	"	"	"		"	1KE.3.4a.5.11.28.39a	
24109	"	"	"	"	"		"	1KE.3.4a.5.11.28.39a	
24110	"	"	36,0	"	"		"	1KE.3.4a.12.28.39a	
24111	"	"	"	"	"		"	1KE.3.4a.12.28.39a	
24112	"	"	38,0	"	"		"	1KE s. 3.4a.12.28.39a	
24113	"	"	"	"	"		"	1KE s. 3.4a.12.28.39a	
24114	"	64	38,5	"	"		"	1KE s. 3.4a.5.11.28.39a	1)
24115	"	"	"	"	"		"	1KE s. 3.4a.5.11.28.39a	1)
24116	"	"	38,0	"	"		"	1KE s. 3.4a.12.28.39a	1)
24117	"	"	"	"	"		"	1KE s. 3.4a.12.28.39a	1)
24118	"	"	"	"	"		"	1KE s. 3.4a.12.28.39a	1)
24119	"	"	"	"	"		"	1KE s. 3.4a.12.28.39a	1)
24120	"	"	"	"	"		"	1KE s. 3.4a.12.28.39a	1)
24121	"	"	"	"	"		"	1KE s. 3.4a.12.28.39a	1)
24122	"	"	"	"	"		"	1KE s. 3.4a.12.28.39a	1)
24123	"	"	"	"	"		"	1KE s. 3.4a.12.28.39a	1)

Mål i () gjelder vg. nr. 24110-24113 og 24116-24123

1) Halvsenkbare vinduer (type Young) etter tegn. 11845

ABo3b

TYPE 3

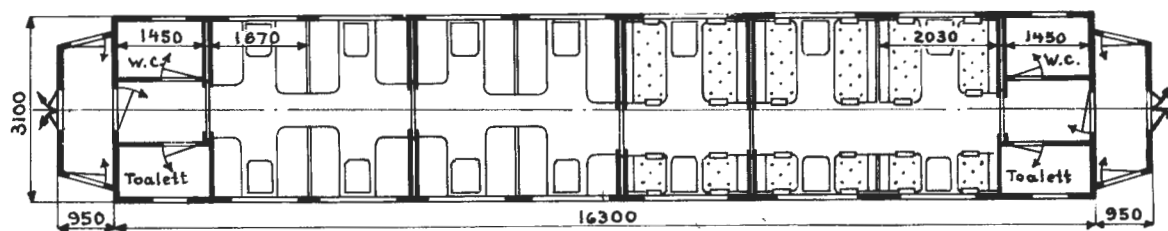
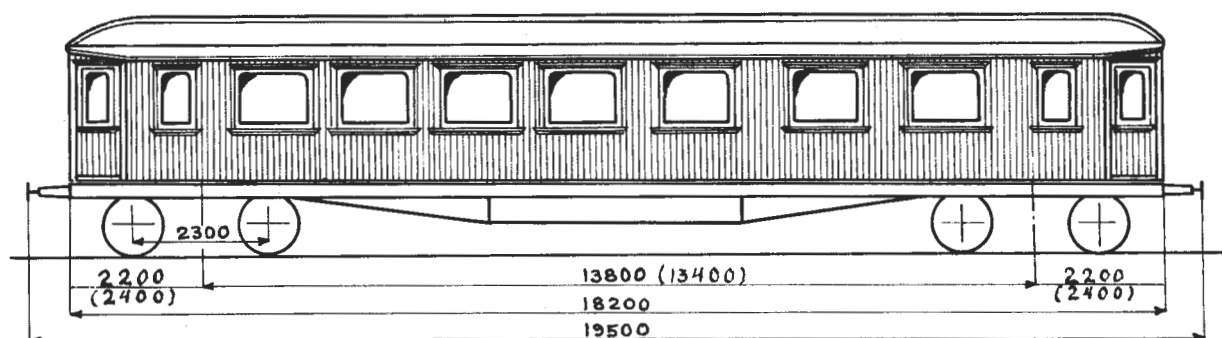

Hovedt. 2095
2247
3201

Vogn nr	Distriktsmerke	Fabrikant	Byggeår	Omr. vognvekt i tonn	Sittepl. pr vogn		Grunnriis	El.varme i kW	Vognutstyr (se side 6)	Merknad
					1	2				
550	D	Skb	14	34,0	18	31			1H.3.5.11.28.39a	1)
551	"	"	"	33,5	"	"			1H.3.5.11.28.39a	1)
552	"	"	"	33,0	"	"			1H.3.5.11.28.39a	1)
18055	"	Str	20	"	"	"			1H.3.5.11.28.39a	2)
18127	T	Skb	31	31,5	"	"			1H.3.11.28.39a	3)
18128	"	"	"	32,5	"	"			1H.3.5.11.28.39a	3) 4)

- 1) Hovedt. 2095
- 2) " 2247
- 3) " 3201. Hvelvet tak
- 4) Faste seter m. arml. i 1. kl. avd.

Mål i () gjelder vg. etter hovedt. 3201

Trykk nr. 751 1.7.66

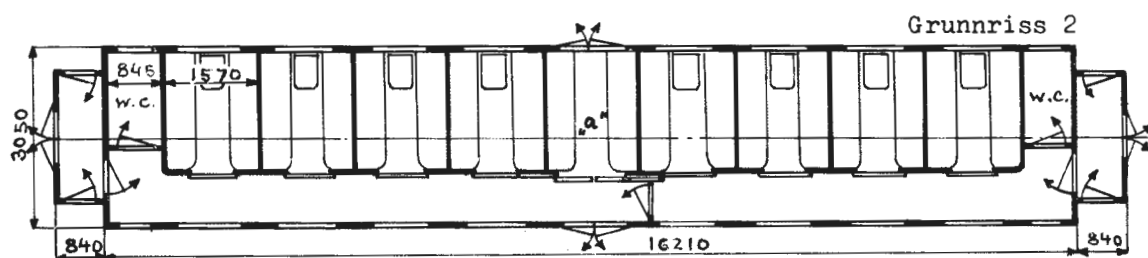
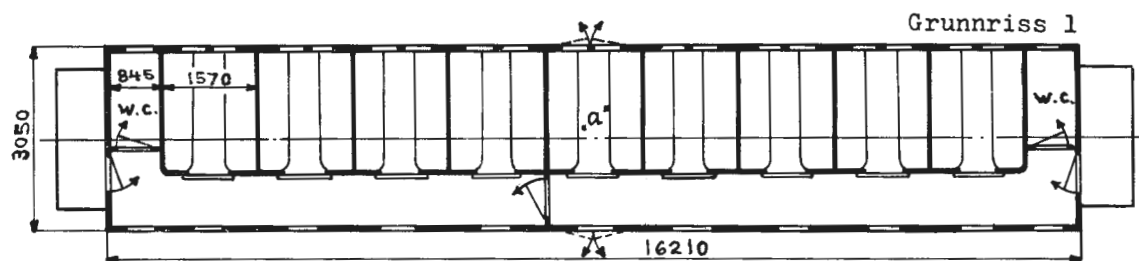
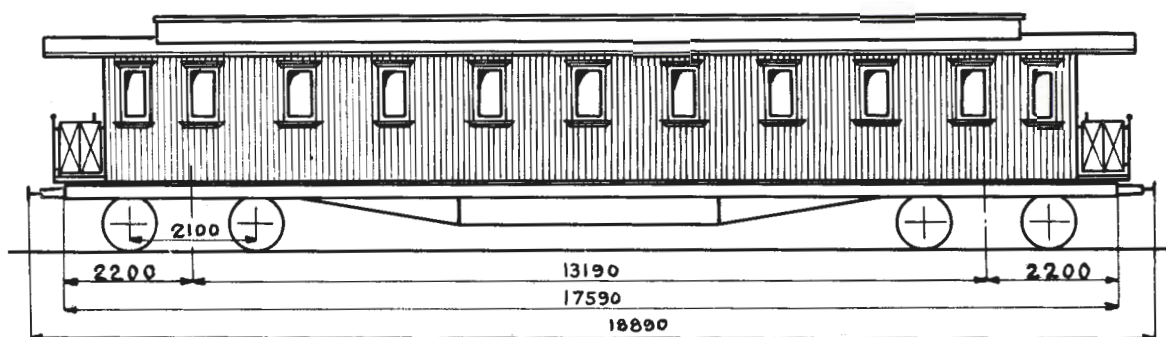

Hovedt. 439

Vogn nr.	Distriktsmerke	Fabrikant	Byggeår	Omr. vognvekt i tonn	Sittepl. 2.klasse	Grunnriss	El. varme i kW	Vognutstyr (se side 6)	Merknad
164	0	Str	01	27,5	72	1		1H.3.5.11.39a	
168	"	"	"	24,5	"	"		1H.3.5.11.39a	
328	"	"	00	25,0	"	"		1H.3.11.39a	1)
334	"	"	01	27,5	"	"		1H.3.11.39a	
337	"	"	"	25,0	"	"		1H.3.11.39a	
841	T	Skb	"	28,0	"	2		1H.3.5.11.28.39a	1)
842	"	"	"	24,5	"	1		1H.3.5.11.39a	
849	"	Str	"	27,0	"	2		1H.3.5.11.28.39a	1)
908	0	"	00	25,5	"	1		1H.3.5.11.39a	
909	"	"	"	26,0	"	"		1H.3.5.11.39a	

1) Sykekupé "a"

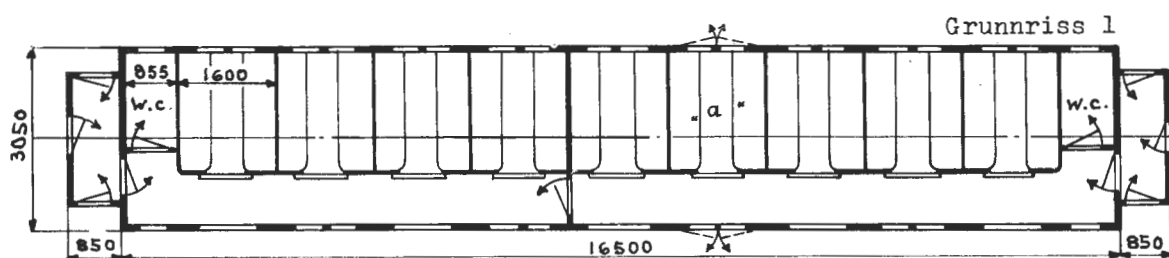
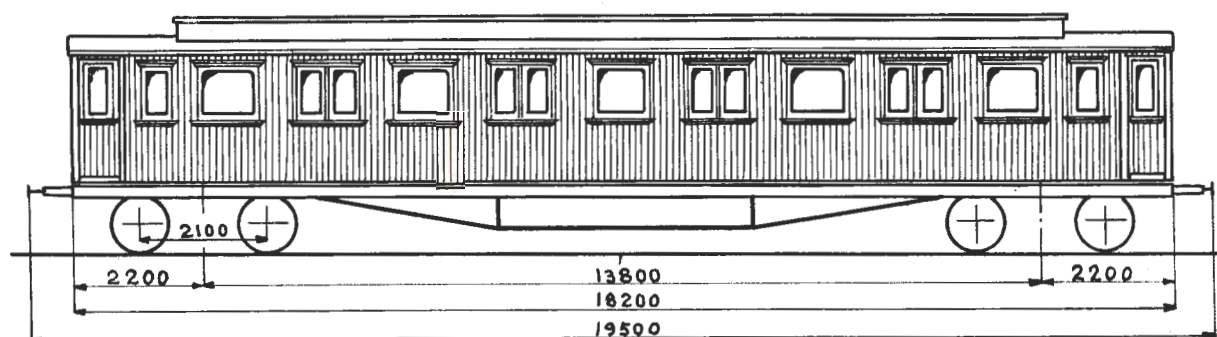
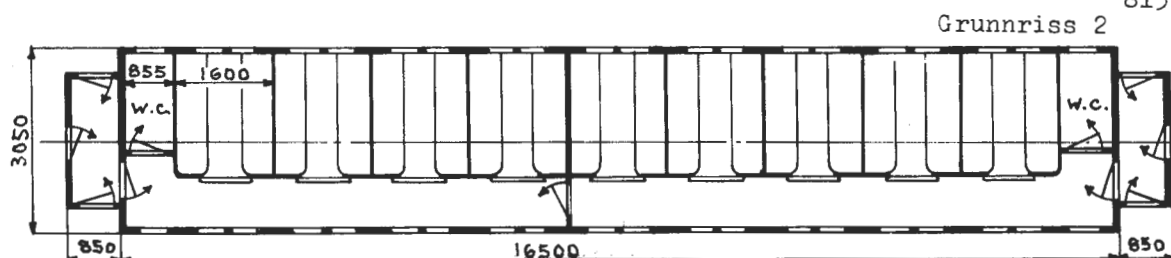
Hovedt. 695
813

Grunnriss 2

Hovedt. 695

Vogn nr.	Distriktsmerke	Fabrikant	Byggeår	Omr. vognvekt i tonn	Sittepl. 2.klasse	Grunnriss	El. varme i kW	Vognutstyr (se side 6)	Merknad
510	D	Skb	09	28,5	72	1		1H.3.11.28.39a	1)
511	"	"	"	29,0	"	"		1H.3.11.28.39a	
931	B	Str	06	29,5	"	2		1H.3.5.11.28.39a	
932	"	"	"	30,0	"	"		1H.3.5.11.28.39a	
934	"	Skb	07	30,5	"	"		1H.3.5.11.28.39a	
935	"	"	08	29,5	"	1		1H.3.5.11.28.39a	
943	"	"	"	"	"	"		1H.3.5.11.28.39a	
957	"	"	04	"	"	2		1H.3.5.11.28.39a	
958	"	"	"	"	"	"		1H.3.5.11.28.39a	
959	"	"	"	27,5	"	"		1H.3.5.11.28.39a	

1) Dobbelte plattformendedører.
Brede enkeltvinduer på begge
vognsider

Trykk nr. 751 1.7.63

Bo2b

TYPE 1

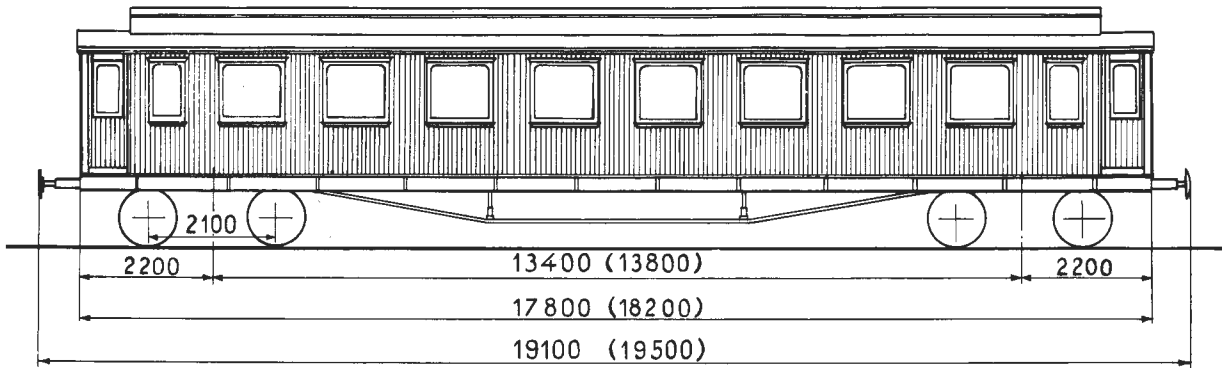

Mål i () gjelder for vogner etter grunnriss 2

Grunnriss 1

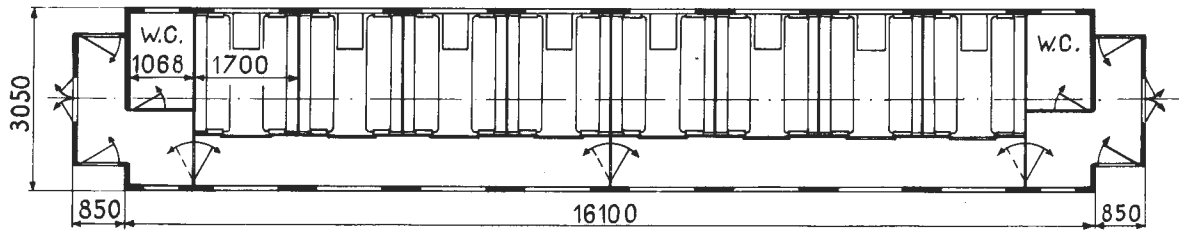

Hovedt.
1057

Grunnriss 2

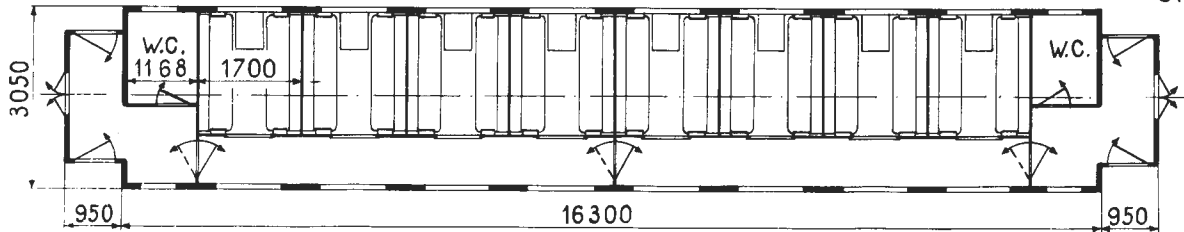

Hovedt.
1057

Vogn nr.	Distriktsmerke	Fabrikant	Byggeår	Omr. vognvekt i tonn	Sittepl. 2.klasse	Grunnriss	El varme i kW	Vognutstyr (se side 6)	Merknad
476	O	Str	11	31,0	64	1		1H.3.5.11.28.39a	
477	"	"	"	30,5	"	"		1H.3.5.11.28.39a	
539	D	Skb	"	"	"	"		1H.3.5.11.28.39a	
540	"	"	"	30,0	"	"		1H.3.11.28.39a	
541	"	"	"	"	"	"		1H.3.5.11.28.39a	
769	H	"	"	25,0	"	"		1H.3.5.11.28.39a	
981	B	Str	"	30,5	"	2		1H.3.5.11.28.39a	
982	"	"	"	29,5	"	"		1H.3.5.11.28.39a	

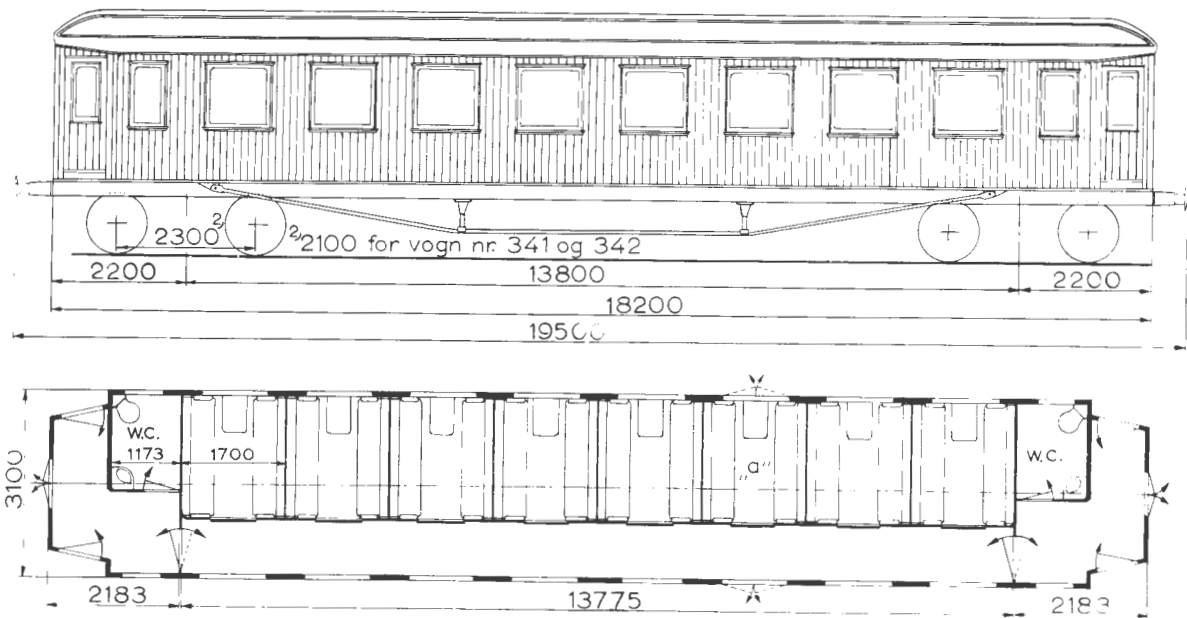
Hovedt. 2090¹⁾
2120¹⁾

Vogn nr.	Distriktsmerke	Fabrikant	Byggeår	Omr vognvekt i tonn	Sittepl 2 klasse	Grunniss	El varme i kW	Vognutstyr (se side 6)	Merknad
153	O	Skb	20	32,5	64			1H. 3. 5. 11. 28. 39a	
154	"	"	"	34,0	"			1H. 3. 5. 11. 28. 39a	
156	"	Str	15	31,5	"			1H. 3.11. 28. 39a	
157	"	"	"	33,5	"			1H. 3. 5. 11. 28. 39a	
171	"	Skb	22	34,0	"			1H. 3. 5. 11. 28. 39a	
172	"	"	"	"	"			1H. 3. 5. 11. 28. 39a	
173	"	"	"	33,0	"			1H. 3. 5. 11. 28. 39a	
174	"	"	"	"	"			1H. 3. 5. 11. 28. 39a	
280	"	"	21	32,0	"			1H. 3. 5. 11. 28. 39a	
281	"	"	"	37,5	"			1H. 3. 11. 28. 39a	
282	"	"	"	34,0	"			1H. 3. 5.11. 28. 39a	
284	"	"	"	34,5	"			1H. 3. 5.11. 28. 39a	
285	"	"	"	33,5	"			1H. 3. 5.11. 28. 39a	
290	"	Kok	"	"	"			1KK. 3. 5.11. 28. 39a	2)
291	"	"	"	"	"			1H. 3. 5.11. 28. 39a	
292	"	"	"	32,5	"			1H. 3. 11. 28. 39a	
293	"	"	"	33,5	"			1KK. 3. 5.11. 28. 39a	
341	"	Str	12	29,5	"			1H. 3. 5.11. 28. 39a	3)
342	"	"	"	30,0	"			1H. 3. 5.11. 39a	3)
343	"	"	15	32,5	"			1H. 3.11. 39a	
344	"	"	"	32,0	"			1H. 3. 5.11. 28. 39a	

1) Utvidet plattform etter tegn. 6559

2) Plattformsidedører slår ut

3) Hovedt. 2090

Bo2b

TYPE 2

Vogn nr.	Distriktsmerke	Fabrikant	Byggeår	Omr. vognvekt i tonn	Sitepl. 2.klasse	Grunnriss	El. varme i kW	Vognutstyr (se side 6)	Merknad
345	O	Skb	17	32,0	64			1H.3.11.28.39a	2)
346	"	"	"	33,5	"			1H.3.5.11.28.39a	
347	"	"	20	33,0	"			1H.3.11.28.39a	
563	D	Str	15	32,0	"			1H.3.11.28.39a	
564	"	"	"	34,0	"			1H.3.5.11.28.39a	
565	"	"	"	32,0	"			1H.3.11.28.39a	
566	"	"	"	32,5	"			1H.3.11.28.39a	
567	"	"	"	33,0	"			1H.3.5.11.28.39a	
568	"	Skb	"	"	"			1H.3.5.11.28.39a	
569	"	"	"	32,0	"			1H.3.11.28.39a	
570	"	"	"	33,5	"			1H.3.5.11.28.39a	
571	"	"	"	33,0	"			1H.3.11.28.39a	
572	"	"	"	34,0	"			1H.3.5.11.28.39a	
580	"	"	21	"	"			1H.3.5.11.28.39a	
623	"	"	22	"	"			1H.3.5.11.28.39a	
637	"	Str	24	32,5	"			1H.3.5.11.28.39a	
638	"	"	"	"	"			1H.3.11.28.39a	
639	"	"	"	33,0	"			1H.3.11.28.39a	
640	"	"	"	33,5	"			1H.3.5.11.28.39a	
744	H	"	25	"	"			1H.3.5.11.28.39a	
745	"	"	"	34,0	"			1H.3.5.11.28.39a	
770	"	Skb	17	"	"			1H.3.5.11.28.39a	
782	"	"	15	32,5	"			1H.3.5.11.28.39a	
783	"	"	"	31,0	"			1H.3.11.28.39a	
876	O	"	21	33,5	"			1H.3.5.11.28.39a	
877	"	Str	19	33,0	"			1H.3.5.11.28.39a	
878	"	"	"	32,5	"			1H.3.5.11.28.39a	
880	"	Skb	20	32,0	"			1H.3.11.28.39a	
884	"	"	18	33,0	"			1H.3.5.11.28.39a	4)
885	"	"	19	32,0	"			1H.3.11.28.39a	
18012	T	"	15	34,0	"			1H.3.5.11.28.39a	
18013	"	"	"	32,5	"			1H.3.5.11.28.39a	
18014	"	"	"	33,0	"			1H.3.5.11.28.39a	
18026	D	Str	"	"	"			1H.3.5.11.28.39a	
18027	"	"	"	"	"			1H.3.5.11.28.39a	
18028	"	"	16	33,5	"			1H.3.11.28.39a	
18037	T	Skb	18	34,0	"			1H.3.5.11.28.39a	
18042	"	"	"	33,5	"			1H.3.5.11.28.39a	
18057	D	"	21	"	"			1H.3.5.11.28.39a	
18058	"	"	"	31,5	"			1H.3.11.28.39a	
18062	"	"	"	34,5	"			1H.3.5.11.28.39a	
18099	B	Kok	"	33,5	"			1H.3.5.11.28.39a	

2) Plattformsidedører slår ut

4) Sykekupé "a"

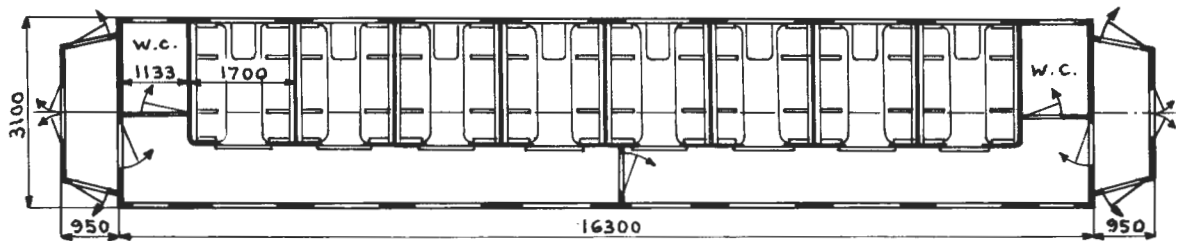
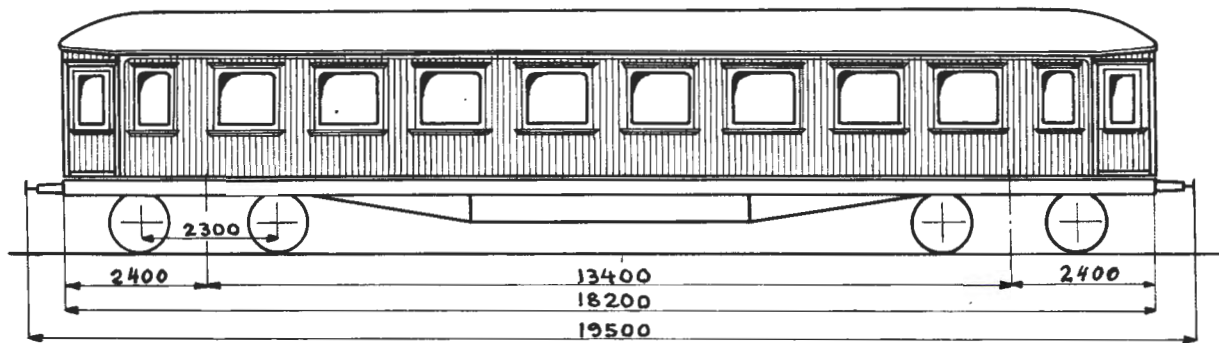

Hovedt. 3320

Vogn nr.	Distriktsmerke	Fabrikant	Byggeår	Omr. vognvekt i tonn	Sittepl. 2.klasse	Grunnriss	El. varme i kW	Vognutstyr (se side 6)	Merknad
224	0	Skb	37	33,5	64			1H.3.5.11.28.39a	
225	"	"	"	34,0	"			1H.3.5.11.28.39a	
226	"	"	"	32,5	"			1H.3.5.11.28.39a	
654	D	Str	34	34,0	"			1H.3.5.11.28.39a	
655	"	"	"	34,5	"			1H.3.5.11.28.39a	
656	"	Skb	35	32,5	"			1H.3.11.28.39a	1)
657	"	"	"	34,0	"			1H.3.5.11.28.39a	1)
660	"	"	36	"	"			1H.3.5.11.28.39a	
661	"	"	"	33,5	"			1H.3.5.11.28.39a	
662	"	"	"	"	"			1H.3.5.11.28.39a	
18131	B	"	33	"	"			1H.3.5.11.28.39a	1)
18132	"	"	"	34,0	"			1H.3.5.11.28.39a	1)
18133	"	"	"	33,5	"			1H.3.5.11.28.39a	1)
18134	"	Str	34	34,0	"			1H.3.5.11.28.39a	1)
18135	"	"	"	33,5	"			1H.3.5.11.28.39a	
18143	"	"	37	32,5	"			1H.3.11.28.39a	
18144	"	"	"	33,0	"			1H.3.5.11.28.39a	
18145	"	"	"	34,0	"			1H.3.5.11.28.39a	

1) Plattformsidedører slår inn

Trykk nr. 751 1.7.66

Bo2b

TYPE 6

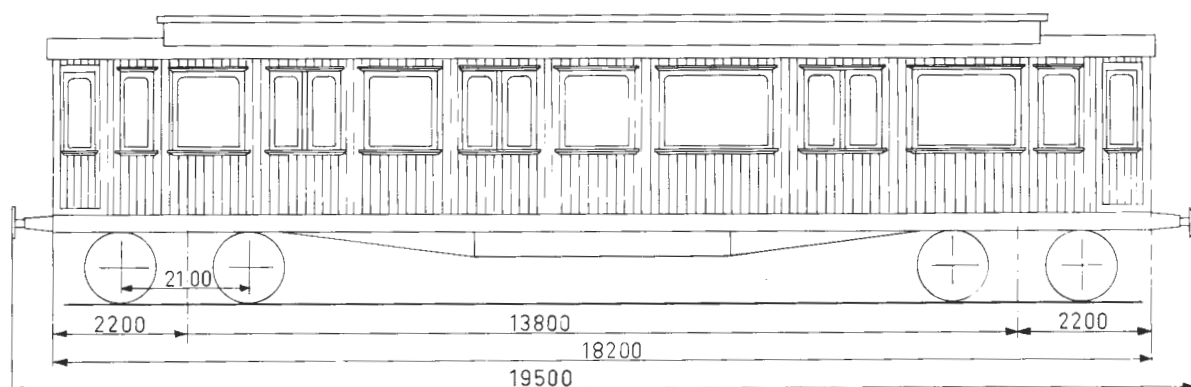

Grunnriss 1

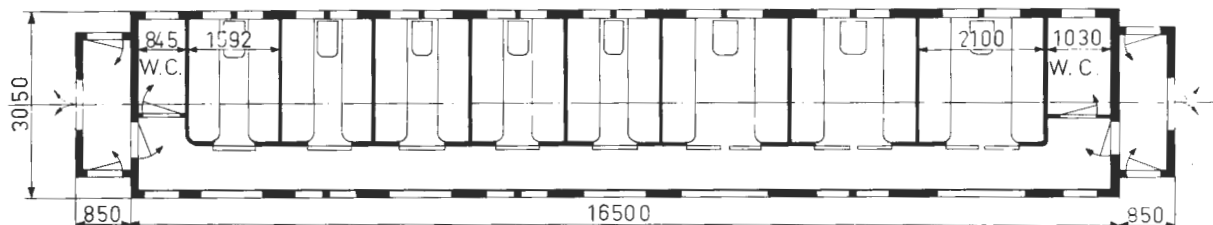

Grunnriss 2

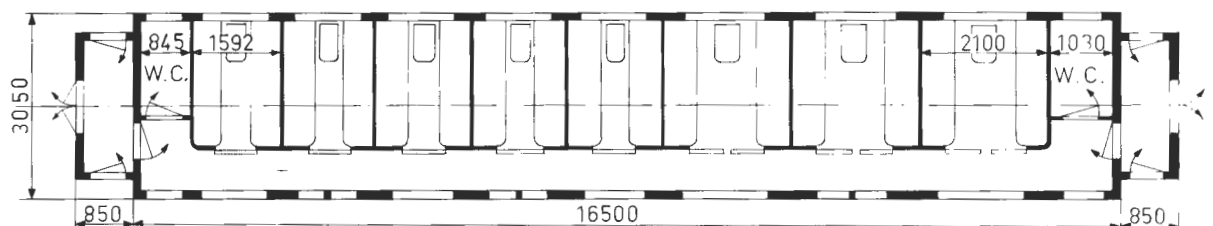

Grunnriss 3

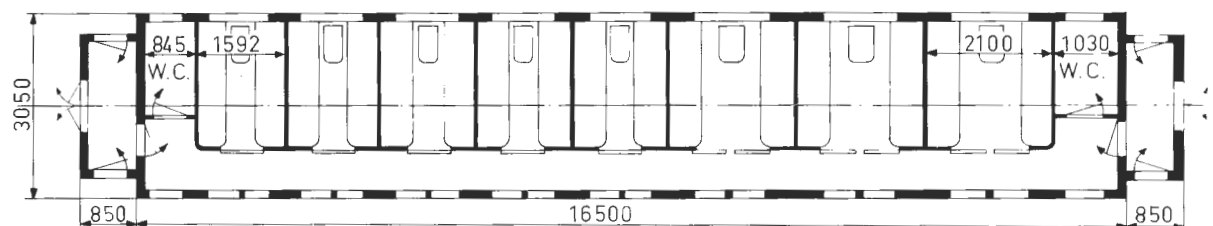

Hovedt. oppr. 699+869

Vogn nr.	Distriktsmerke	Fabrikant	Byggeår	Omr. vognvekt i tonn	Sittepl. 2.klasse	Grunnriss	EL. varme i kW	Vognutstyr (se side 6)	Merknad
307	O	Skb	09	30,5	64	2		1H.3.5.11.28.39a	
503	D	Str	"	30,0	"	"		1H.3.5.11.28.39a	
505	"	"	"	28,0	"	1		1H.3.5.11.28.39a	
506	"	"	"	30,0	"	2		1H.3.5.11.28.39a	
507	"	"	"	"	"	"		1H.3.5.11.28.39a	1)
508	"	"	"	"	"	1		1H.3.5.11.28.39a	1)

1) Brede enkeltvinduer på begge vognsider

Vogn nr.	Distriktsmerke	Fabrikant	Byggeår	Omtr. vognvekt i tonn	Sittepl. 2.klasse	Grunnriss	El. varme i kW	Vognutstyr (se side 6)	Merknad
923	B	Str	05	28,5	64	2		1H.3.11.28.39a	
925	"	"	08	29,5	"	1		1H.3.5.11.28.39a	
926	"	"	"	29,0	"	2		1H.3.5.11.28.39a	
927	"	"	"	"	"	1		1H.3.5.11.28.39a	
955	H	"	04	29,5	"	3		1H.3.5.11.39a	
956	B	"	"	"	"	2		1H.3.5.11.28.39a	

Bo2c

TYPE 5

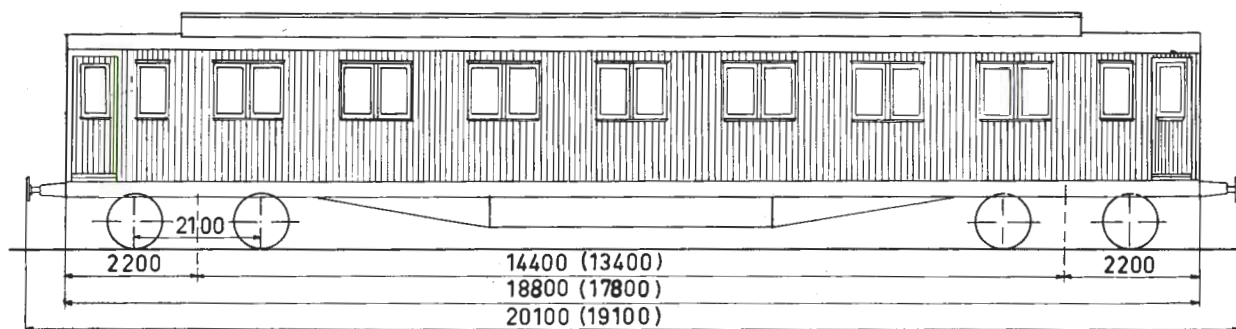

Mål i () gjelder for grunnriss 2

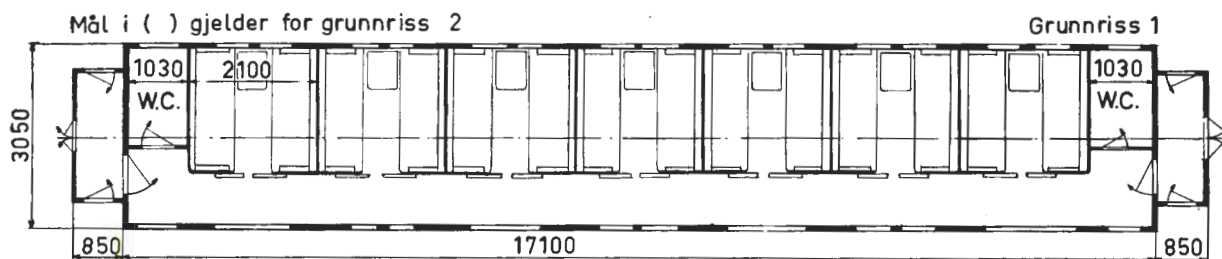

Grunnriss 2

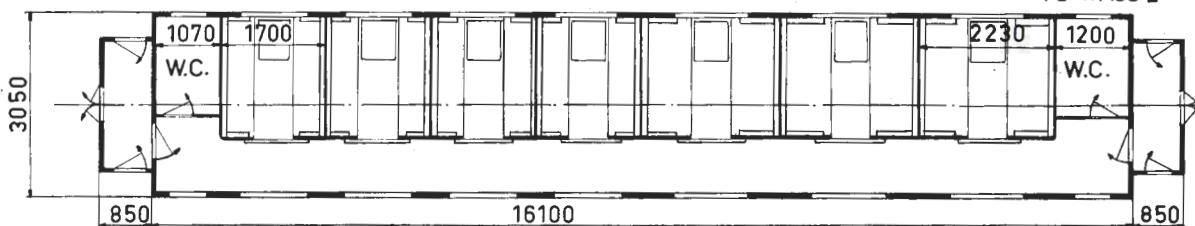

Grunnriss 3

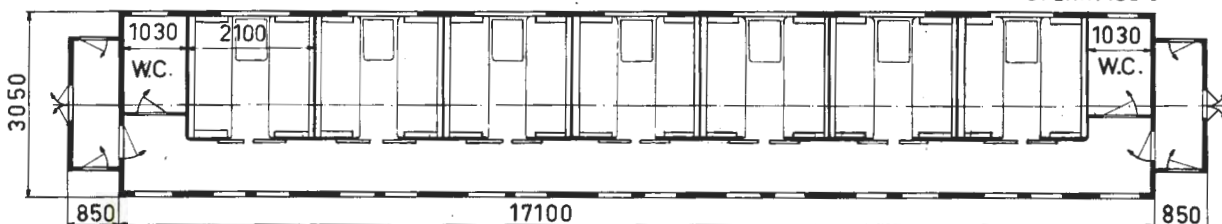

Oppr. hovedt. gr.r. 1: 700-958, gr.r. 2: 1058, gr.r. 3: 700

Vogn nr.	Distriktsmerke	Fabrikant	Byggeår	Omr. vognvekt i tonn	Sittepl. 2. klasse	Grunnriss	El. varme i kW	Vognutstyr (se side 6)	Merknad
473	O	Str	11	31,0	56	2		1H.3.5.11.28.39a	
501	D	Skb	09	29,5	"	1		1H. 3. 12.28.39a	1)
502	"	"	"	31,5	"	"		1H.3.5.11.28.39a	
542	"	Str	11	31,0	"	2		1H.3.5.11.28.39a	
543	"	"	"	30,0	"	"		1H.3.5.11.28.39a	
544	"	"	"	29,0	"	"		1H.3.5.11.28.39a	
928	B	Skb	05	29,5	"	3		1H.3.5.11.28.39a	
929	"	"	"	"	"	"		1H.3.5.11.28.39a	2)
930	"	"	09	30,0	"	"		1H.3.5.11.28.39a	2)
951	"	"	04	29,0	"	"		1H.3.5.11.28.39a	

1) Brede enkeltvinduer i kupéer

2) " " " sidegang

Trykk nr. 751 1.7.62

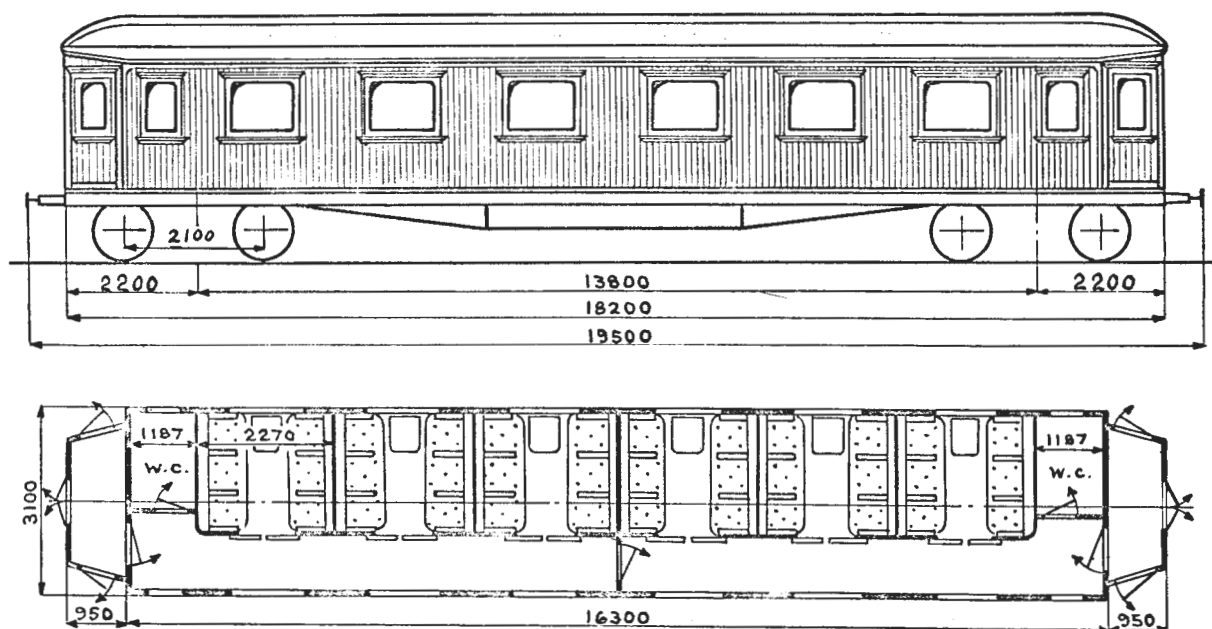
Oppr. hovedt. 699¹⁾

Vogn nr.	Distriktsmerke	Fabrikant	Byggeår	Omr. vognvekt i tonn	Sittepl. 2.klasse	Grunnriss	El. varme i kW	Vognutstyr (se side 6)	Merknad
504	D	Str	09	30,5	48			1H.3.5.11.28.39a	

1) Ny vognkasse

Trykk nr. 751 1.7.66

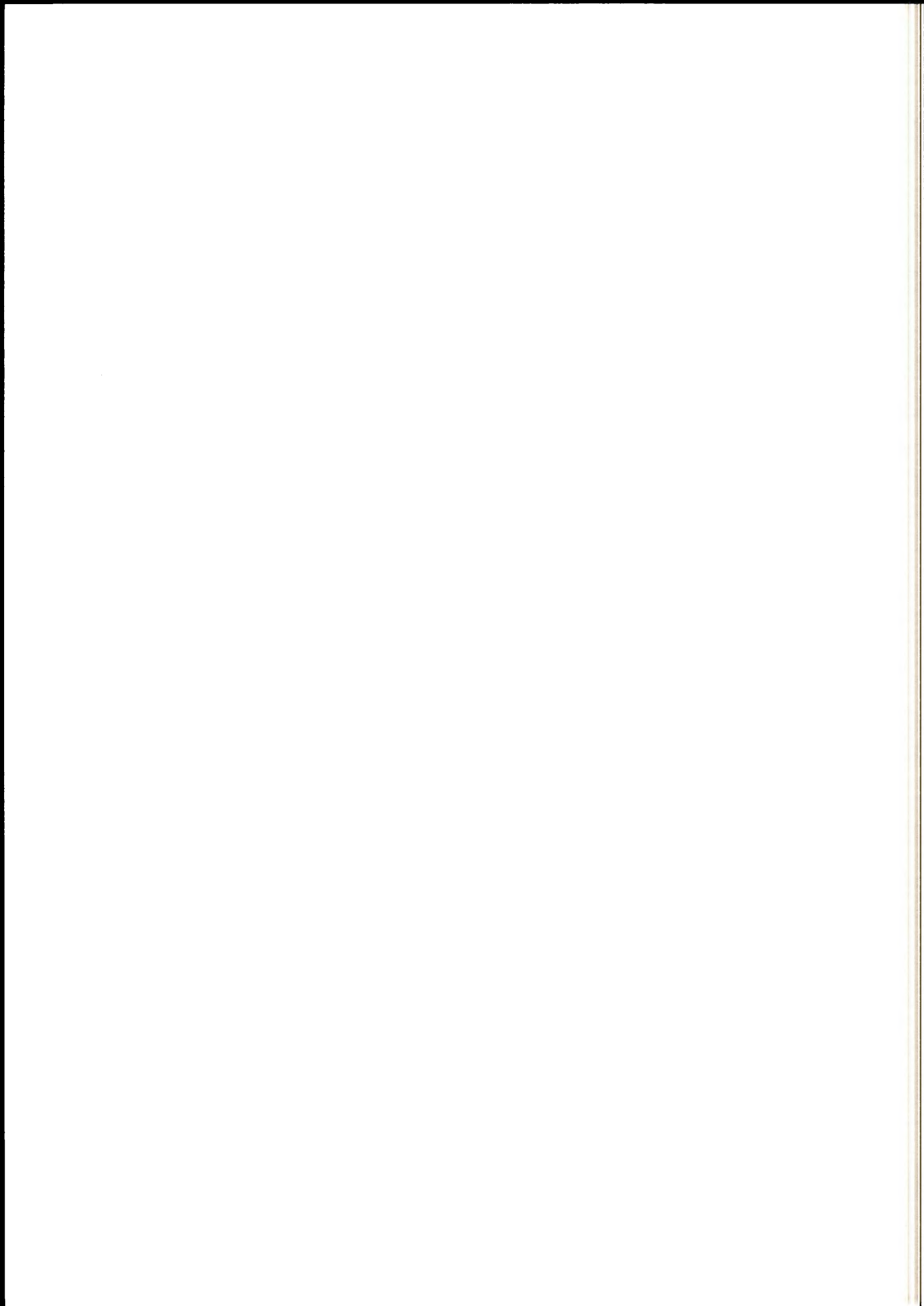

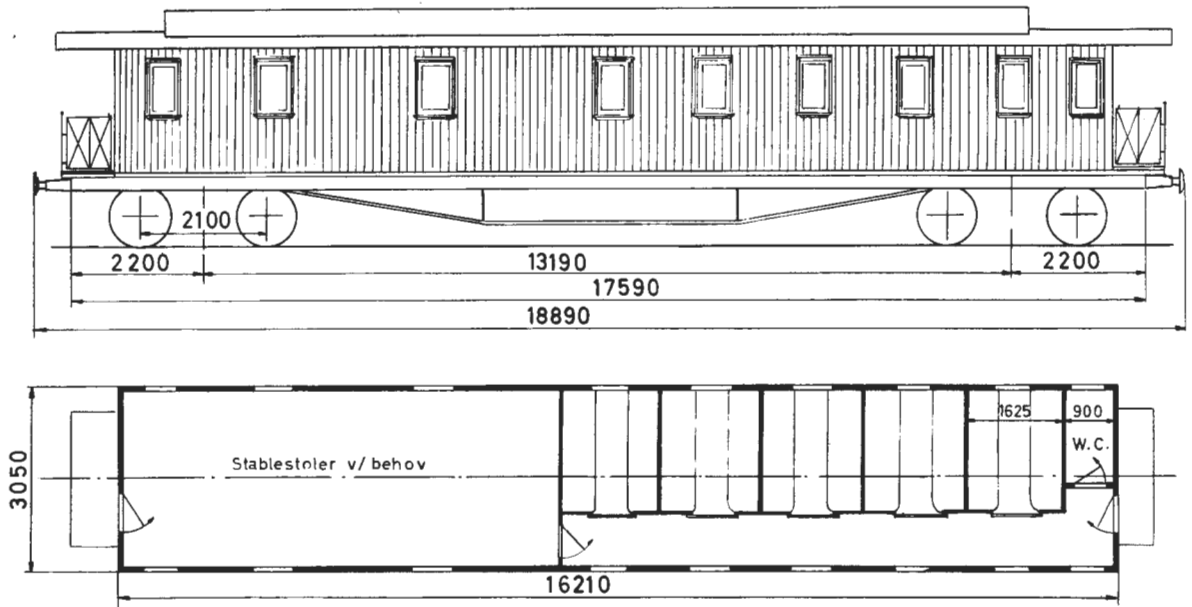

Oppr. hovedt. 460

Vogn nr.	Distriktsmerke	Fabrikant	Byggeår	Omtr. vognvekt i tonn	Sittepl. 2.klasse	Grunnriss	El.varme i kW	Vognutstyr (se side 6)	Merknad
182	O	Sk b	00	26,0	40	-		1H.3.11.39a	

Bo3a

TYPE 1

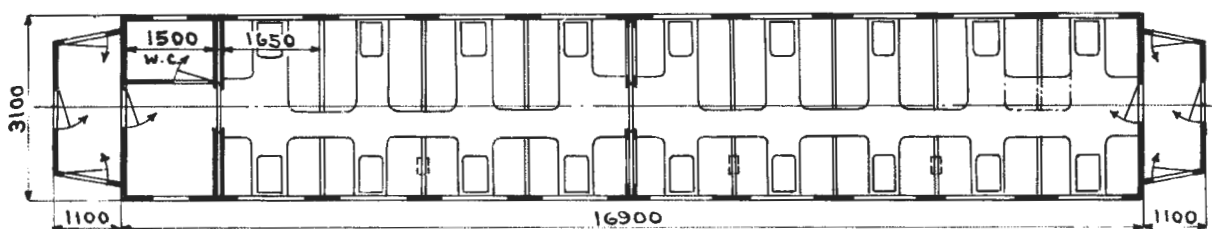
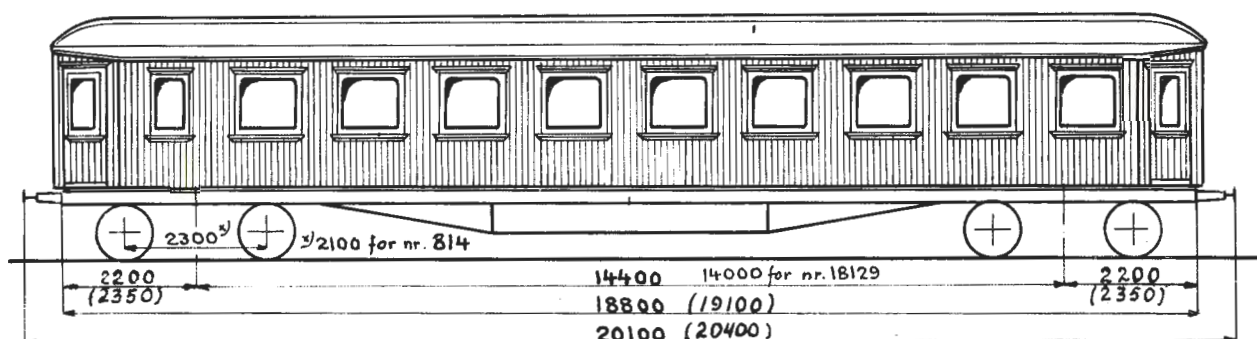

Mål i () gjelder vogner som har fått montert overgangsbelger (post 28 i utstyrsrubrikken).

Hovedt. 1843
2062
2966

Vogn nr.	Distriktsmerke	Fabrikant	Byggeår	Omt. vognvekt i tonn	Sittepl. 2.klasse	Grunnriss	El. varme i kW	Vognutstyr (se side 6)	Merknad
175	O	Skb	23	31,5	84			1H.3.5.11.39a	1)
176	"	Str	25	32,5	"			1H.3.5.11.39a	1)
177	"	"	"	32,0	"			1H.3.5.11.28.39a	1) 4)
179	"	"	"	31,0	"			1H.3.5.11.28.39a	1) 3) 4)
186	"	"	"	31,5	"			1H.3.5.11.28.39a	1) 4)
217	"	"	30	30,5	"			1H.3.11.39a	2)
219	"	"	"	31,0	"			1H.3.5.11.28.39a	2) 4)
631	D	Skb	23	"	"			1H.3.5.11.39a	1) 4)
634	"	"	"	28,5	"			1H.3.5.11.39a	1)
635	"	"	"	30,0	"			1H.3.5.11.28.39a	1) 4)
636	"	"	24	32,0	"			1H.3.5.11.28.39a	1) 4)
651	K	"	29	31,0	"			1H.3.11.28.39a	2) 4)
788	H	"	24	32,0	"			1H.3.5.11.28.39a	1) 4)

- 1) Hovedt. 1843
- 2) " 2966. Hvelvet tak
- 3) Plattformsidedører slår ut
- 4) Dobbelte plattformendedører

Trykk nr. 751 1.7.66

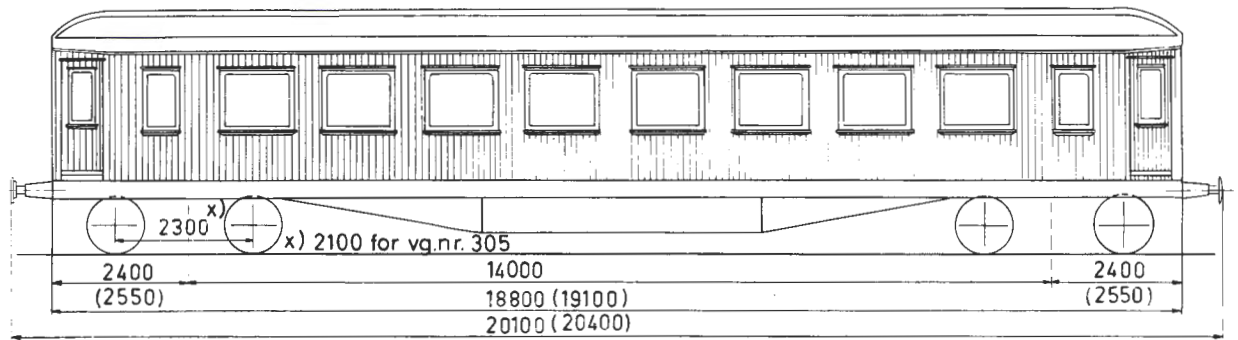

Mål i () gjelder vogn nr.18138

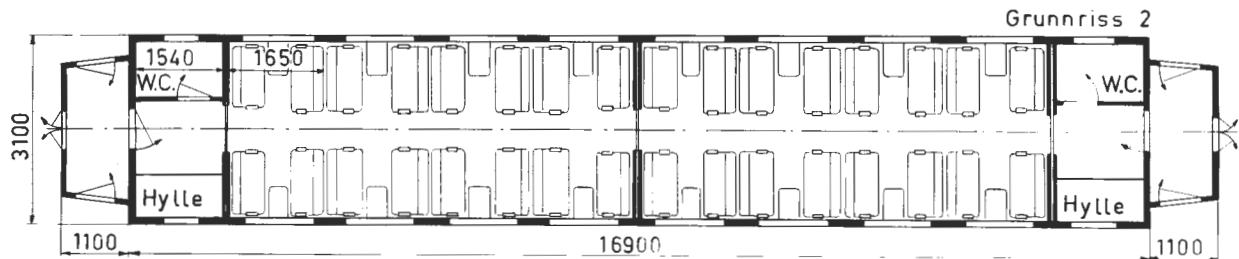
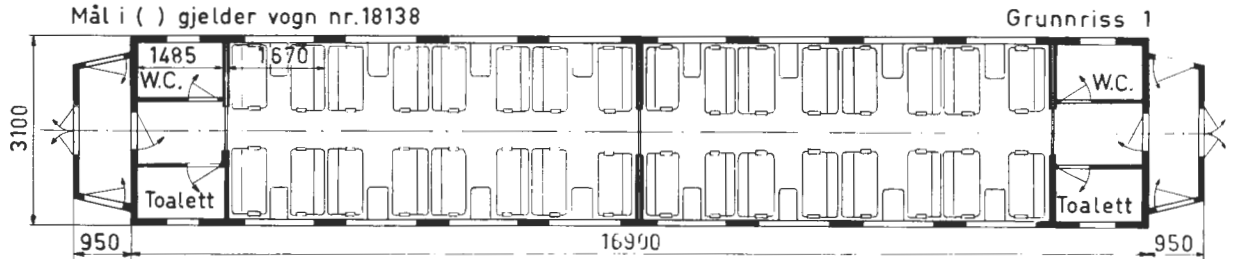

Hovedt. gr.r. 1: 4194. Oppr. hovedt. gr.r. 2: 4000

Vogn nr	Distriktsmerke	Fabrikant	Byggeår	Omr. vognvekt i tonn	Sittepl. 2. klasse	Grunniss	El.varme i kW	Vognutstyr (se side 6)	Merknad
294	O	Str	21	31,5	64	1		1H.3.5.11.28.39a	1)
305	"	Skb	08	30,0	"	"		1H.3.5.11.28.39a	1)
645	K	"	28	32,5	"	"		1H.3.5.11.28.39a	1)
665	D	"	37	32,0	"	"		1H.3. 11.28.39a	2)
666	"	"	"	"	"	"		1H.3.5.11.28.39a	2)
707	H	Str	26	33,0	"	"		1H.3.5.11.28.39a	1)
747	O	Skb	28	32,5	"	"		1H.3.5.11.28.39a	1)
18036	T	Str	16	33,5	"	"		1H.3.5.11.28.39a	1)
18049	"	Skb	17	33,0	"	"		1H.3.5.11.28.39a	1)
18138	"	Str	37	32,0	"	2		1H.3.5.11.28.39a	1)
18146	B	Skb	"	32,5	"	1		1H.3.5.11.28.39a	2)
18147	"	"	"	33,5	"	"		1H.3.5.11.28.39a	2)
18148	"	"	"	33,0	"	"		1H.3.5.11.28.39a	2)
18149	"	"	"	32,5	"	"		1H.3.11.28.39a	2)

1) Nye vognkasser

2) Plattformsidedører slår ut

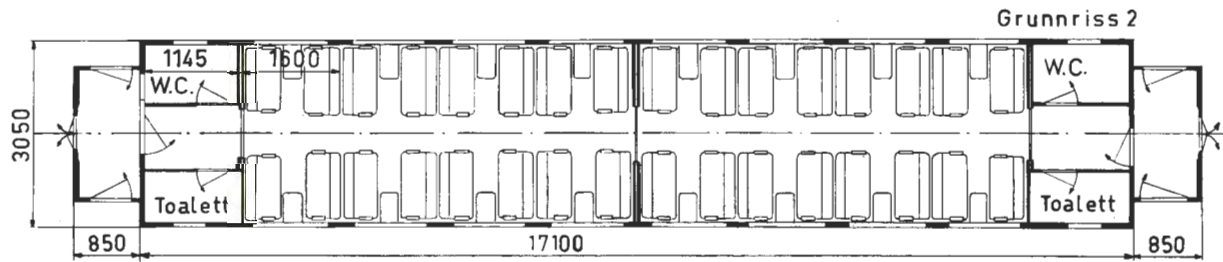
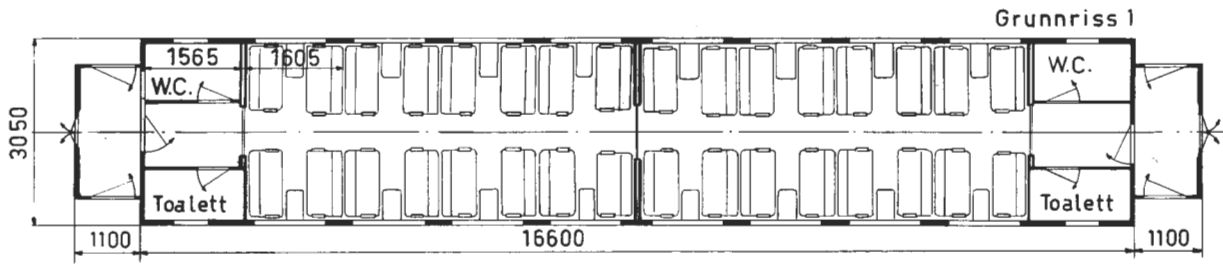
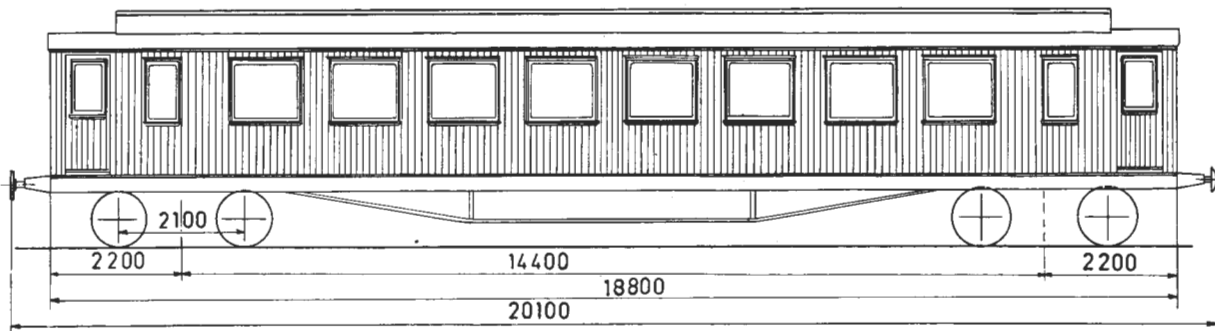

Hovedt. gr. r. 1:999, oppr. hovedt. gr. r. 2: 922

Vogn nr.	Distriktsmerke	Fabrikant	Byggear	Omtr. vognvekt i tonn	Sittepl. 2.klasse	Grunnriss	El.varme i kW	Vognutstyr (se side 6)	Merknad
899	O	Skb	09	28,0	64	2		1H. 3. 5. 11. 28. 39a	1)
920	B	Str	"	30,0	"	1		1H. 3. 5. 11. 28. 39a	
948	"	Skb	10	28,5	"	2		1H. 3. 5. 11. 28. 39a	
973	"	Str	09	29,5	"	1		1H. 3. 5. 11. 28. 39a	
974	"	"	"	"	"	"		1H. 3. 5. 11. 28. 39a	
975	"	"	"	28,5	"	"		1H. 3. 11. 28. 39a	

1) Enkle plattformendedører

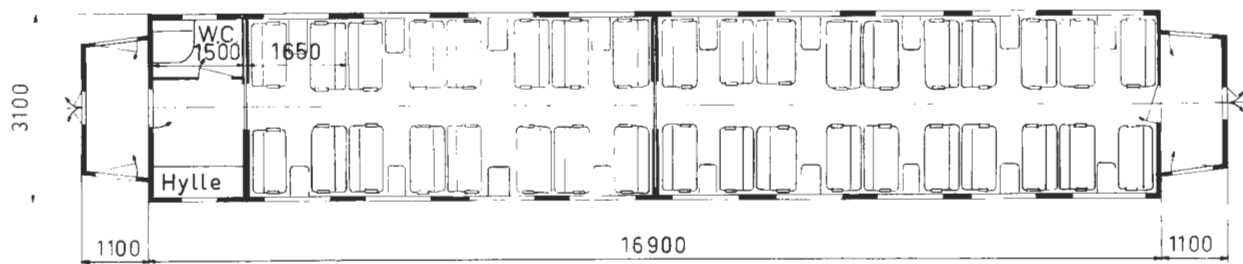
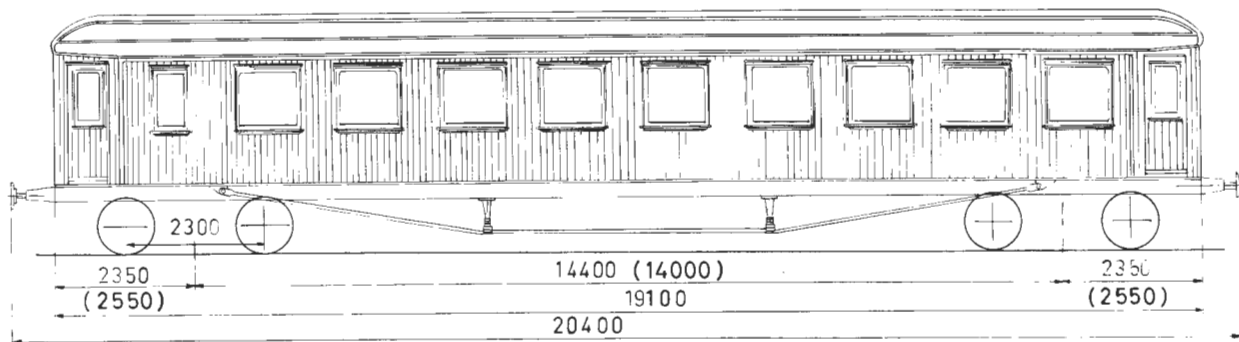

1843
Oppr. hovedt. 2966
4000

Vogn nr.	Distriktsmerke	Fabrikant	Byggeår	Omtr. vognvekt i tonn	Sittepl. 2.klasse	Grunnriss	El.varme i kW	Vognutstyr (se side 6)	Merknad
180	O	Str	25	34,0	72			1H.3.5.11.28.39a	
187	"	"	"	33,0	"			1H.3.5.11.28.39a	
603	K	Kok	20	32,0	"			1H.3.5.11.28.39a	
633	D	Skb	23	"	"			1H.3.5.11.39a	
643	"	Str	26	"	"			1H.3.5.11.28.39a	1)
658	"	"	36	32,5	"			1H.3.5.11.28.39a	2) 3)
18053	T	"	17	33,0	"			1H.3.5.11.28.39a	
18110	"	Skb	24	"	"			1H.3.5.11.28.39a	

Mål i () gjelder vogn nr. 658

1) Oppr. hovedt. 2966

2) " " 4000

3) Har toalettrom istedenfor hylle

Bo3d

TYPE 1

Trevogner med platekledning

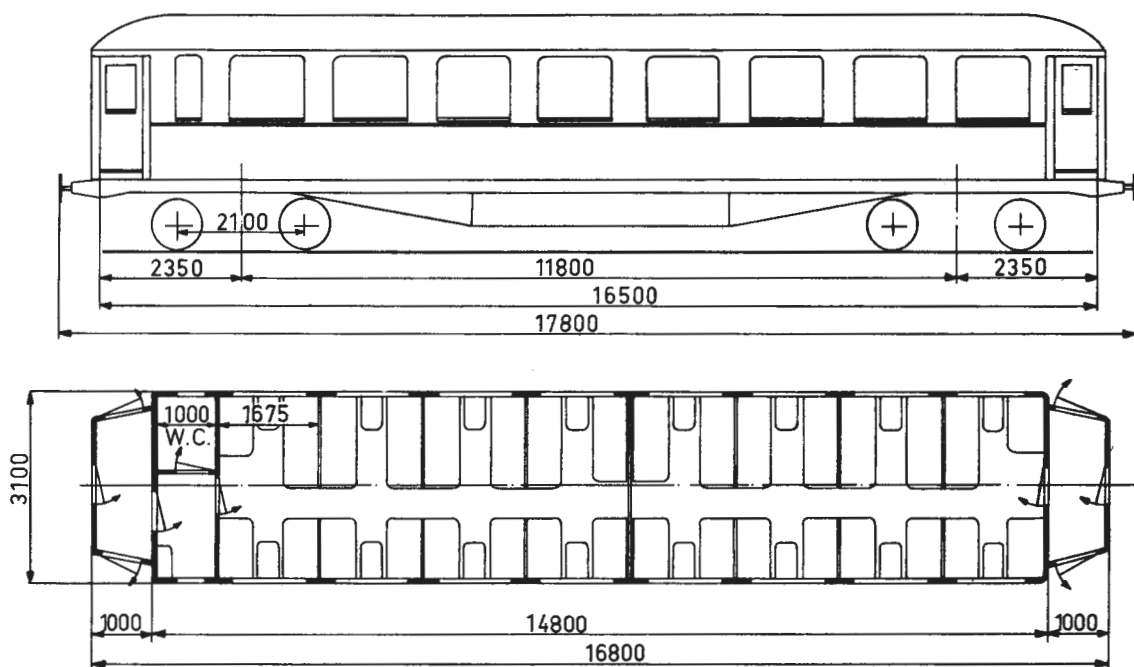

Hovedt. 3590

Vogn nr.	Distriktsmerke	Fabrikant	Byggear	Omr. vognvekt i tonn	SittepL2.klasse	Grunnriss	El.varme i kW	Vognutstyr (se side 6)	Merknad
450	B	Skb	34	21,5	78			1H.3.5.12.39a	} Tilhenger for motorvogn
451	"	"	"	21,0	"			1H.3.5.12.39a	
452	"	"	"	"	"			1H.3.5.12.39a	
453	"	"	"	22,0	"			1H.3.5.12.39a	

Bo3d
 TYPE 2
 Lettmetallvogner

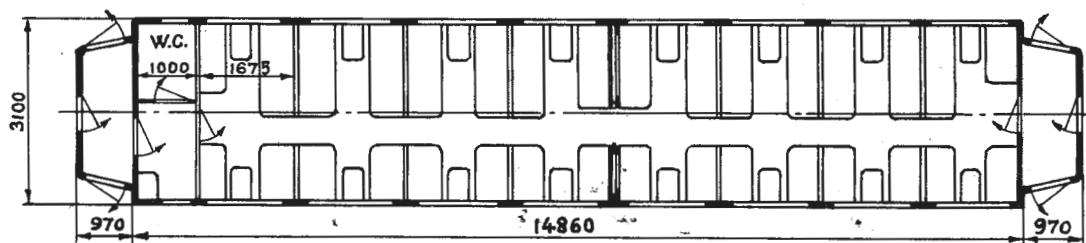
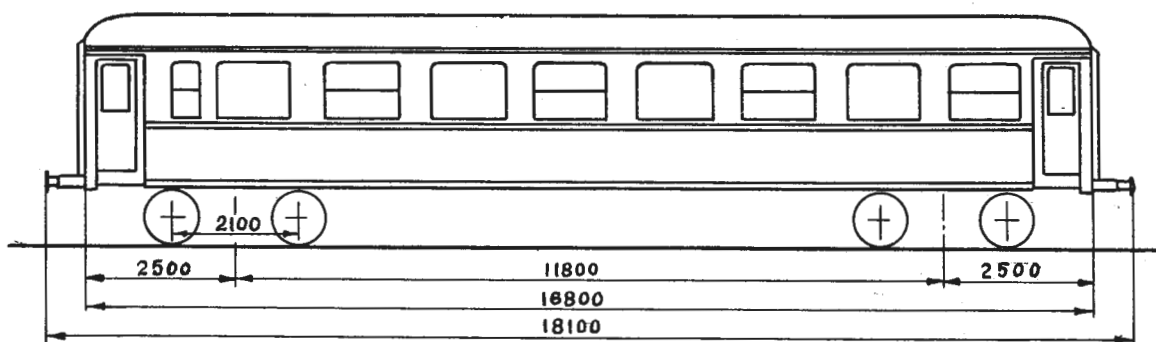

Hovedt. 5190

Vogn nr.	Distriktsmerke	Fabrikant	Byggeår	Omtr. vognvekt i tonn	Sittepl. 2.klasse	Grunnriss	El. varme i kW	Vognutstyr (se side 6)	Merknad
18171	B	Str	47	20,0	78			1H.3.6.12.39a	
18172	"	"	"	"	"			1H.3.6.12.39a	
18173	"	"	"	"	"			1H.3.6.12.39a	

Bo3f

TYPE 1
Stålvogner

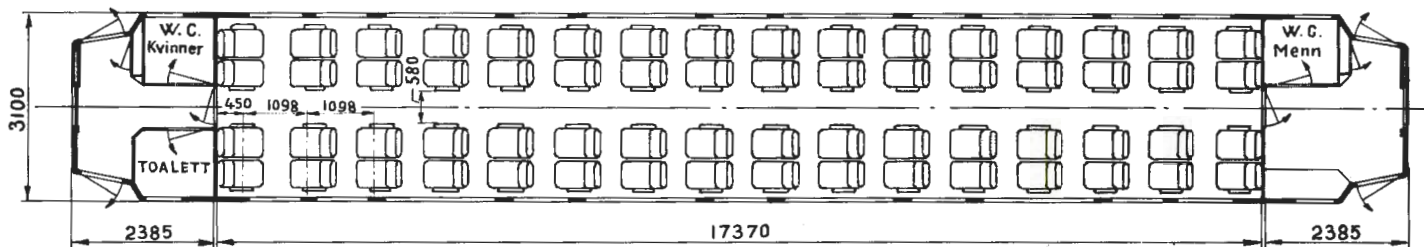
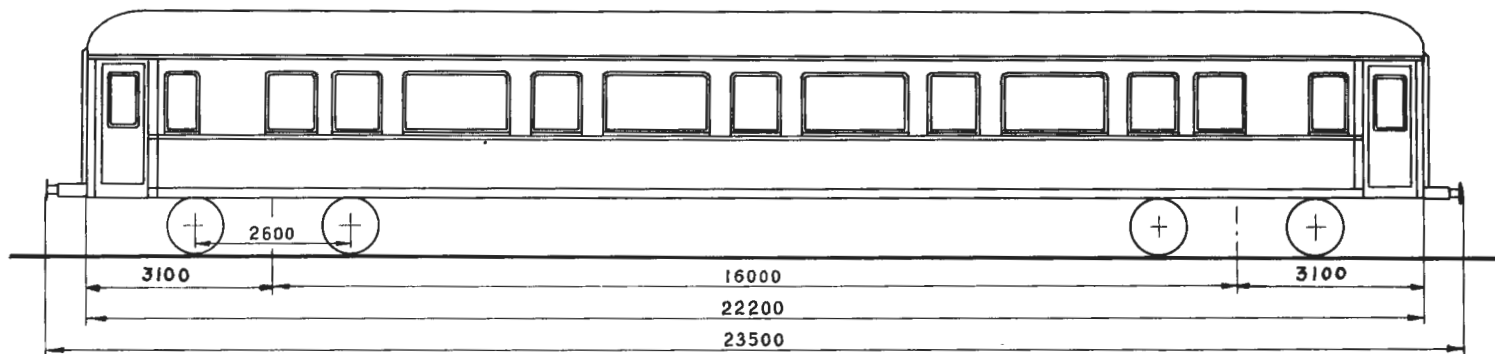

Hovedt. 5971

Vogn nr.	Distriktsmerke	Fabrikant	Byggeår	Omr. vognvekt i tonn	Sittep. 2.klasse	Grunnriss	El. varme i kW	Vognutstyr (se side 6)	Merknad
25503	0	Skb	50	39,0	64	31		1KE.3.5.11.28.39a	
25504	"	"	"	38,0	"	"		1KE.3.5.11.28.39a	
25505	"	"	"	"	"	"		1KE.3.5.11.28.39a	
25506	"	"	"	"	"	"		1KE.3.5.11.28.39a	
25507	"	"	"	"	"	"		1KE.3.5.11.28.39a	
25508	"	"	51	37,5	"	"		1KE.3.5.11.28.39a	
25509	"	"	"	38,5	"	"		1KE.3.5.11.28.39a	
25510	"	"	"	38,0	"	"		1KE.3.5.11.28.39a	
25512	D	"	"	"	"	"		1KE.3.5.11.28.39a	
25513	"	"	"	37,5	"	"		1KE.3.5.11.28.39a	
25514	"	"	"	38,0	"	"		1KE.3.5.11.28.39a	
25515	"	"	"	"	"	"		1KE.3.5.11.28.39a	
25516	"	"	"	38,5	"	"		1KE.3.5.11.28.39a	
25517	"	"	52	"	"	"		1KE.3.5.11.28.39a	
25518	"	"	"	38,0	"	"		1KE.3.5.11.28.39a	
25519	"	"	"	39,0	"	"		1KE.3.5.11.28.39a	
25520	"	"	"	37,5	"	"		1KE.3.5.11.28.39a	
25521	0	"	"	38,0	"	"		1Hs.3.5.11.28.39a	
25525	"	"	"	37,5	"	"		1Hs.3.5.11.28.39a	

Trykk nr. 751 1.7.66

Vogn nr.	Distriktsmerke	Fabrikant	Byggeår	Omt. vognvekt i tonn	Sittepl. 2.klasse	Grunnriss	El. varme i kW	Vognutstyr (se side 6)	Merknad
25526	0	Skb	53	38,0	64		31	1Hs.3.5.11.28.39a	
25530	"	"	"	"	"		"	1Hs.3.5.11.28.39a	

Bo3g

TYPE 1
Stålvogner

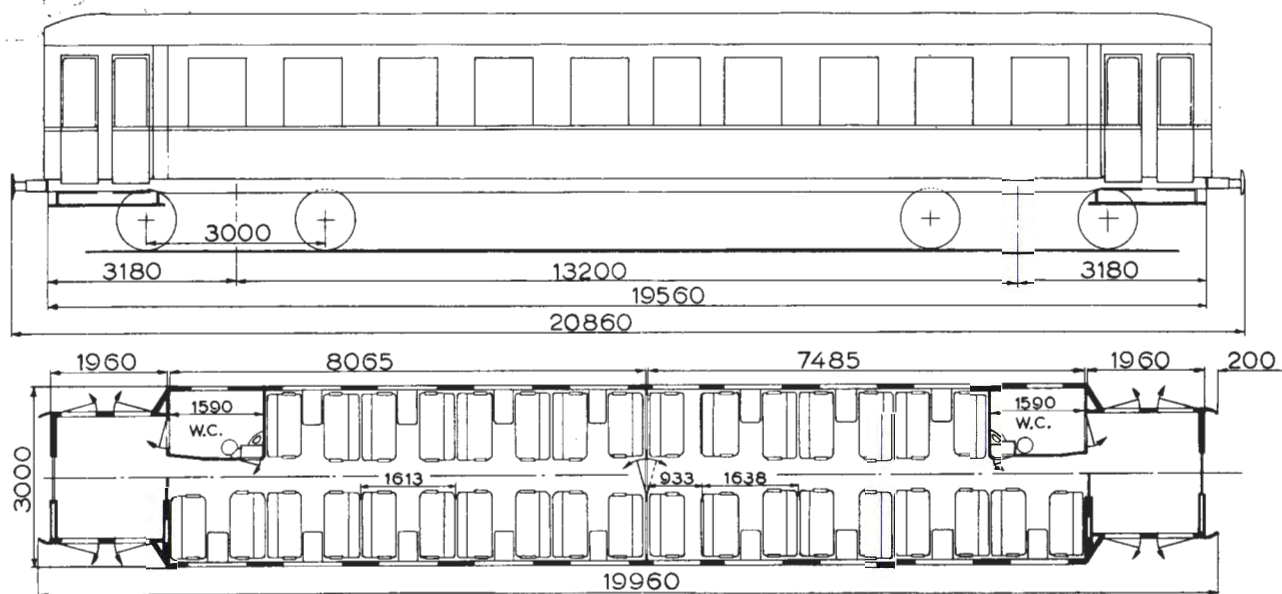

Hovedt. 7442

Vogn nr.	Distriktsmerke	Fabrikant	Byggeår	Omt. vognvekt i tonn	Sittepl. 2.klasse	Grunnriss	El. varme i kW	Vognutstyr (se side 6)	Merknad
19922	O		39	32,5	68	27	1H. 3. 5. 11. 28. 39a		
19923	"	"	"	"	"	"	1H. 3. 5. 11. 28. 39a		
19924	"	"	"	"	"	"	1H. 3. 5. 11. 28. 39a		
19925	"	"	"	"	"	"	1H. 3. 5. 11. 28. 39a		
19926	"	"	"	33,0	"	"	1H. 3. 5. 11. 28. 39a		
19927	"	"	"	32,5	"	"	1H. 3. 5. 11. 28. 39a		
19928	"	"	"	"	"	"	1H. 3. 5. 11. 28. 39a		
19929	"	"	40	"	"	"	1H. 3. 5. 11. 28. 39a		

Bo31
TYPE 2
Stålvogner

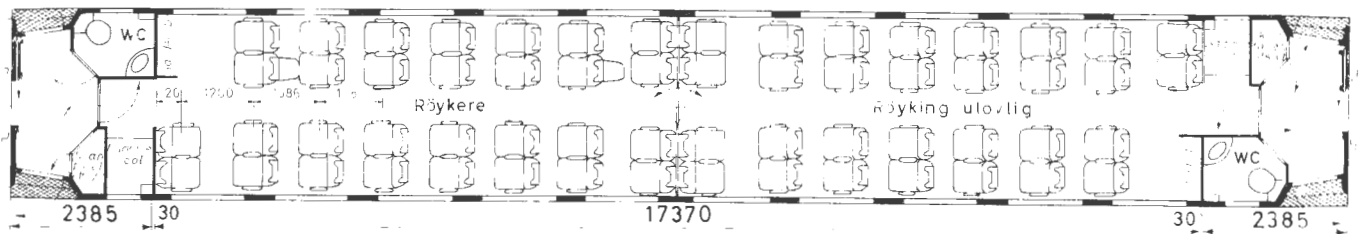
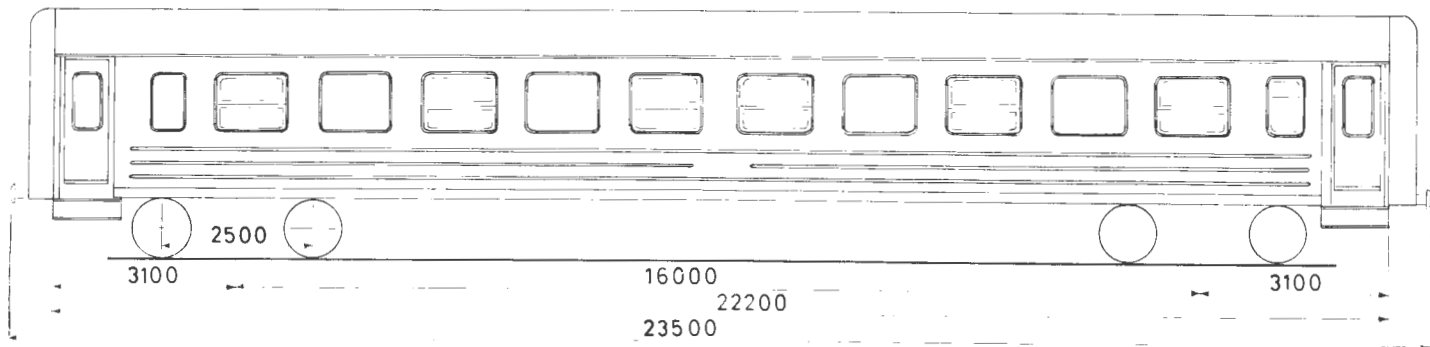

Hovedt. 14030

Vogn nr.	Distriktsmerke	Fabrikant	Byggeår	Omtr. vognvekt i tonn	Sittepl. 2 klasse	Grunnriss	El. varme i KW	Vognutstyr (se side 6)	Merknad
25563	Str		64	37,5	60		50	IKEs. 3.12.28.39b	
25564	"	"	"	"	"		"	IKEs. 3.12.28.39b	
25565	"	"	"	"	"		"	IKEs. 3.12.28.39b	
25566	"	"	"	"	"		"	IKEs. 3.12.28.39b	
25567	"	"	"	"	"		"	IKEs. 3.12.28.39b	
25568	"	"	"	"	"		"	IKEs. 3.12.28.39b	
25569	"	"	"	"	"		"	IKEs. 3.12.28.39b	
25570	"	"	"	"	"		"	IKEs. 3.12.28.39b	
25571	"	"	"	"	"		"	IKEs. 3.12.28.39b	
25572	"	"	"	"	"		"	IKEs. 3.12.28.39b	
25573	"	"	65	"	"		"	IKEs. 3.12.28.39b	
25574	"	"	"	"	"		"	IKEs. 3.12.28.39b	
25575	"	"	66	"	"		"	IKEs. 3.12.28.39b	
25576	"	"	"	"	"		"	IKEs. 3.12.28.39b	
25577	"	"	"	"	"		"	IKEs. 3.12.28.39b	
25578	"	"	"	"	"		"	IKEs. 3.12.28.39b	
25579	"	"	"	"	"		"	IKEs. 3.12.28.39b	
25580	"	"	"	"	"		"	IKEs. 3.12.28.39b	
25581	"	"	"	"	"		"	IKEs. 3.12.28.39b	
25582	"	"	"	"	"		"	IKEs. 3.12.28.39b	
25583	"	"	"	"	"		"	IKEs. 3.12.28.39b	
25584	"	"	"	"	"		"	IKEs. 3.12.28.39b	
25585	"	"	"	"	"		"	IKEs. 3.12.28.39b	

Bo3m

TYPE 1

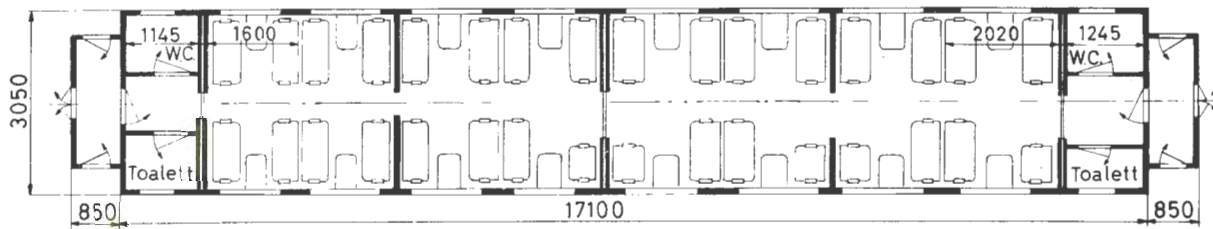
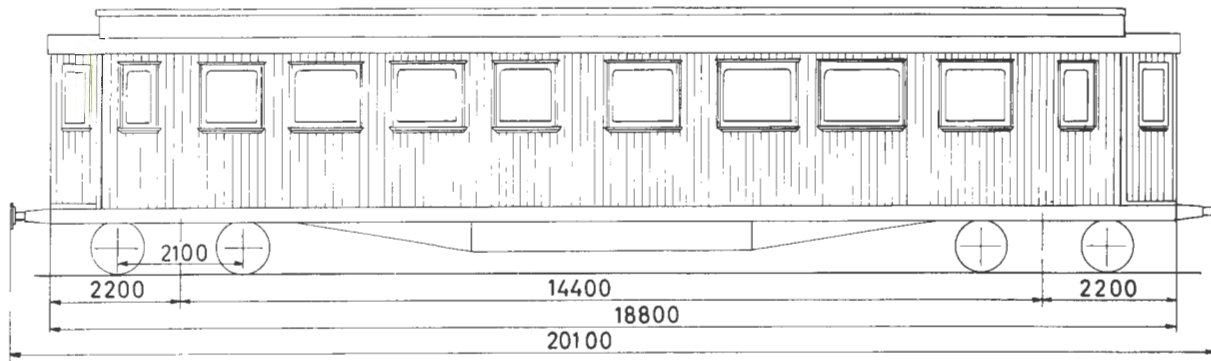

Oppr. hovedt. 922 1)

Vogn nr.	Distriktsmerke	Fabrikant	Byggeår	Omtr. vognvekt i tonn	Sittepl. 2. klasse	Grunnriss	El.varme i kW	Vognutstyr (se side 6)	Merknad
306	O	Str	08	29,0	59			1H. 3.11. 28. 39a	
898	"	Skb	09	30,5	"			1H. 3. 5. 11. 28. 39a	
919	"	Str	08	30,0	"			1H. 3. 5. 11. 28. 39a	
949	B	Skb	10	31,0	"			1H. 3. 5. 11. 28. 39a	

1) Forandr. etter Stb.Vst.O. skisse 973

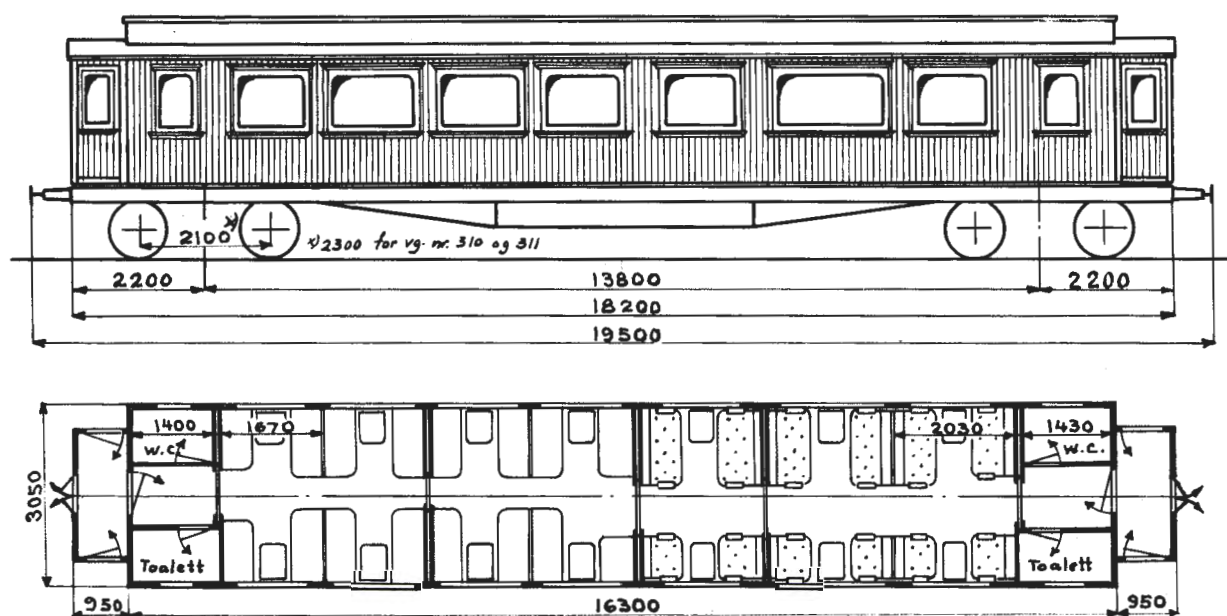

Hovedt. 1200

Vogn nr.	Distriktsmerke	Fabrikant	Byggeår	Omr. vognvekt i tonn	Sittepl. 2.klasse	Grunnriss	El. varme i kW	Vognutstyr (se side 6)	Merknad
308	0	Skb	11	28,5	49			1H.3.5.11.28.39a	
310	"	Str	13	32,0	"			1H.3.5.11.28.39a	1)
311	"	"	"	"	"			1H.3.5.11.39a	1)

1) Hovedt. 2095

Bo3p
Type 1
Stålvogner

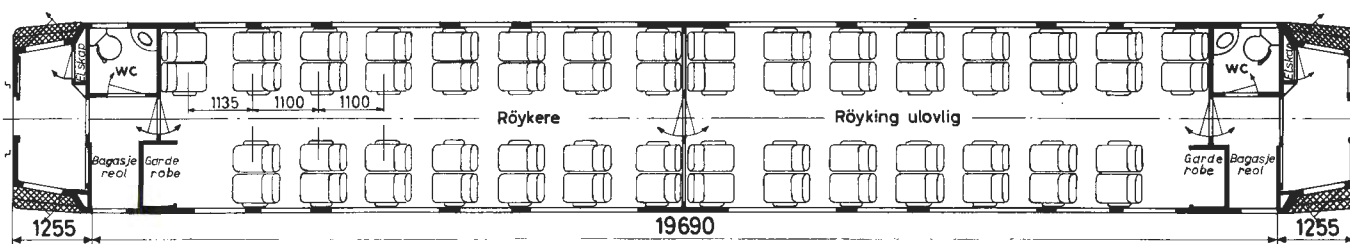
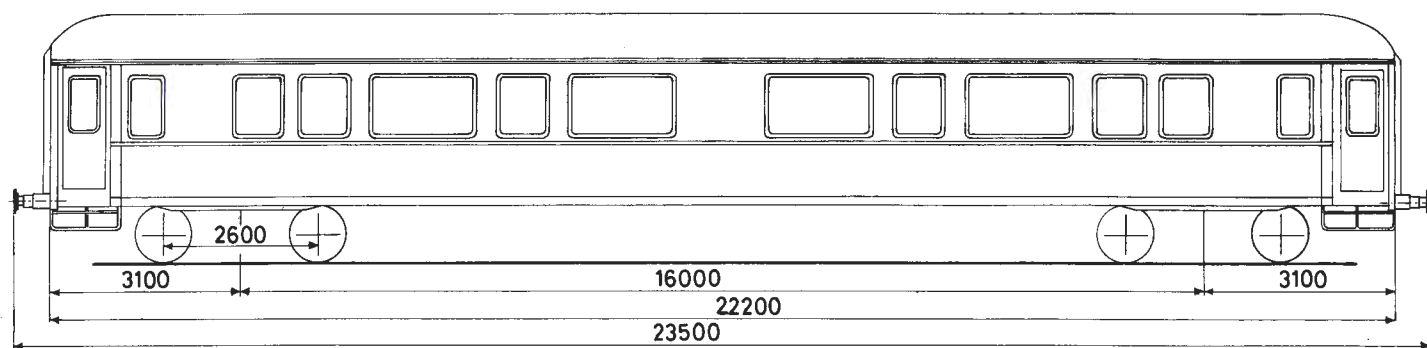

Hovedt. 12238
Oppr. hovedt. 5971

Vogn nr.	Distriktsmerke	Fabrikan	Byggeår	Omkr. vognvekt i tonn	Sitteplasser 2. kl.	Grunnriss	El. varme i KW	Vognutstyr (se side 6)	Merknad
25501	O	Skb	50	38,0	60		31	1KE. 3.5.11.28.39a	
25502	"	"	"	"	"		"	1KE. 3.5.11.28.39a	
25511	D	"	51	39,0	"		"	1KE. 3.5.11.28.39a	
25522	O	"	52	"	"		"	1Hs. 3.5.11.28.39a	
25523	"	"	"	37,5	"		"	1Hs. 3.5.11.28.39a	
25524	"	"	"	38,5	"		"	1Hs. 3.5.11.28.39a	
25527	"	"	53	38,0	"		"	1Hs. 3.5.11.28.39a	
25528	T	"	"	39,0	"		"	1Hs. 3.5.11.28.39a	
25529	"	"	"	"	"		"	1Hs. 3.5.11.28.39a	

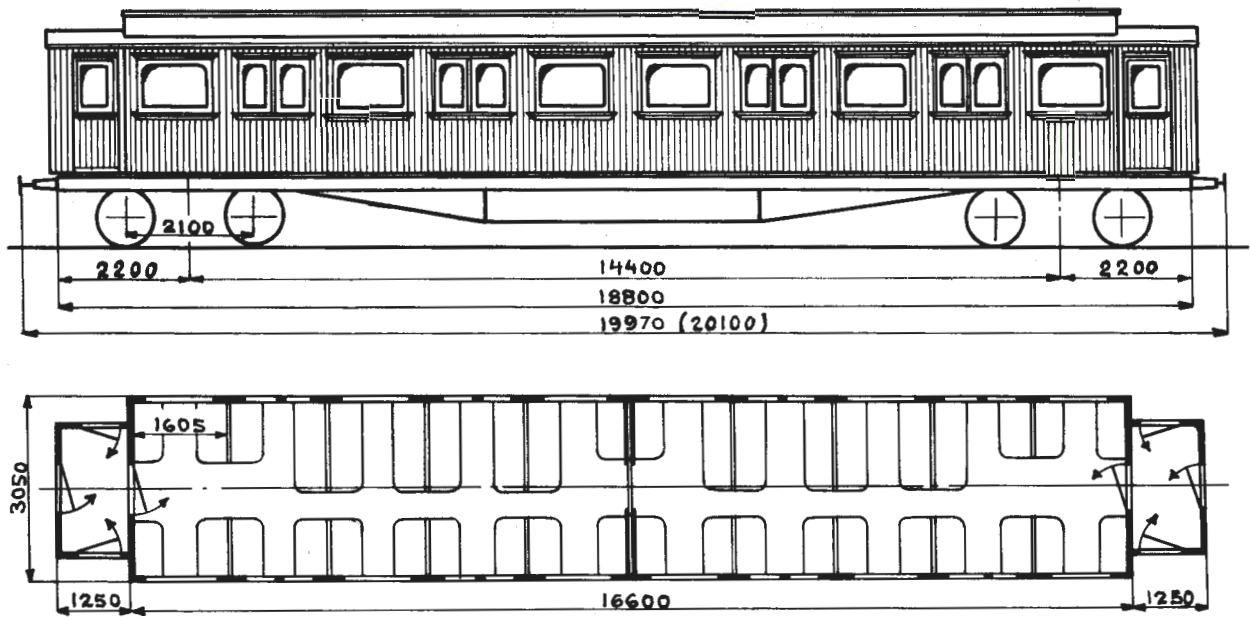

Hovedt. 704

Vogn nr.	Distriktsmerke	Fabrikant	Byggeår	Omr. vognvekt i tonn	Sittepl. 2.klasse	Grunnriss	El.varme i kW	Vognutstyr (se side 6)	Merknad
966	B	Str	04	26,0	92			1H.3.5.11.39a	Ny vognkasse etter tegn. 5897
967	"	"	"	26,5	"			1H.3.5.11.39a	
968	"	"	"	"	"			1H.3.5.11.39a	
969	"	"	"	27,5	"			1H.3.5.11.39a	
970	"	"	"	25,0	"			1H.3.5.11.39a	

Bo4b

TYPE 4

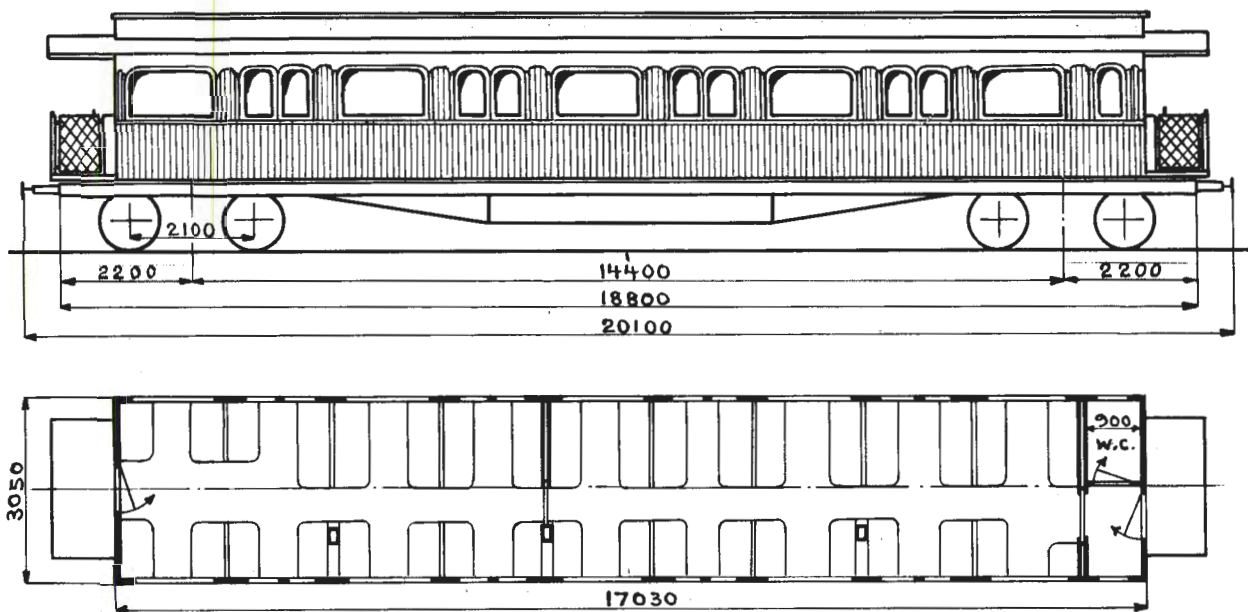

Hovedt. B. 175

Vogn nr.	Distriktsmerke	Fabrikant	Byggear	Omtr. vognvekt i tonn	Sittepl. 2.klasse	Grunnriss	El.varme i kW	Vognutstyr (se side 6)	Merknad
78	0	Str	07	27,5	86			1H.3.5.11.39a	

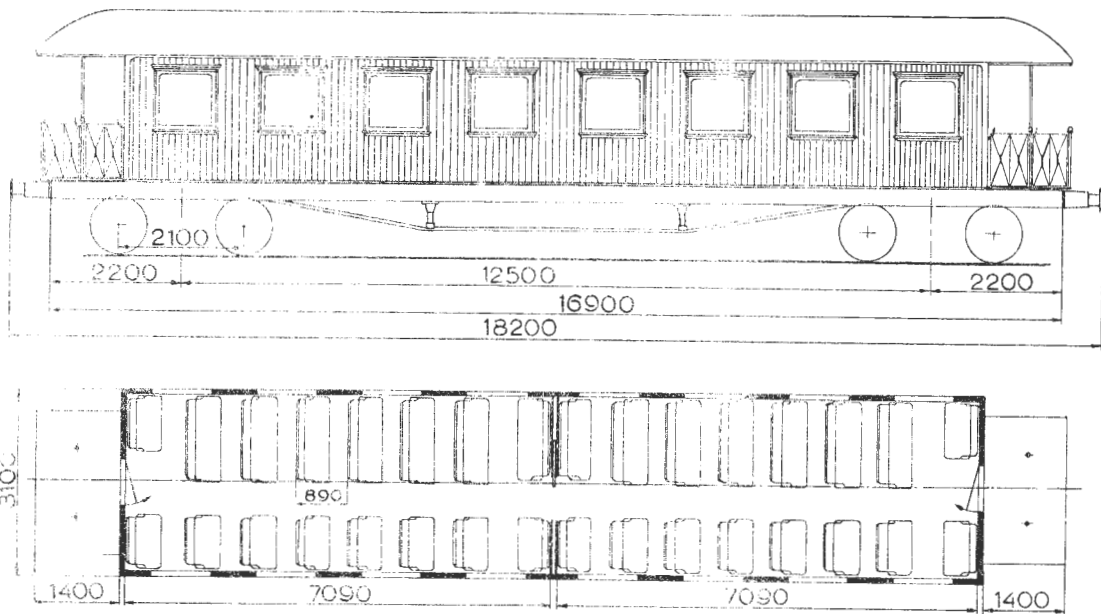

Hovedt. 2369

Vogn nr.	Distriktsmerke	Fabrikant	Byggeår	Omr. vognvekt i tonn	Sittepl. 2.klasse	Grunnriss	El. varme i kW	Vognutstyr (se side 6)	Merknad
39	0	SJv	20	28,5	78			1H.3.5.11.39a	
44	"	"	"	27,5	"			1H.3.11.39a	
47	"	"	"	28,5	"			1H.3.5.11.39a	
586	D	Scd	"	27,5	"			1H.3.5.11.39a	
587	"	"	"	"	"			1H.3.5.11.39a	
601	"	Skb	22	28,5	"			1H.3.11.39a	
605	"	SMv	21	27,5	"			1H.3.5.11.39a	
606	"	"	"	"	"			1H.3.11.39a	
607	"	"	"	27,0	"			1H.3.11.39a	
608	"	"	"	"	"			1H.3.11.39a	
609	"	"	"	"	"			1H.3.11.39a	
610	"	"	"	27,5	"			1H.3.11.39a	

Bo4d

TYPE 2

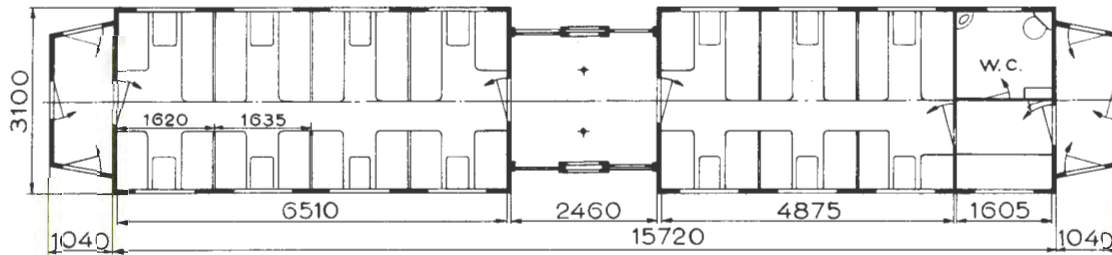
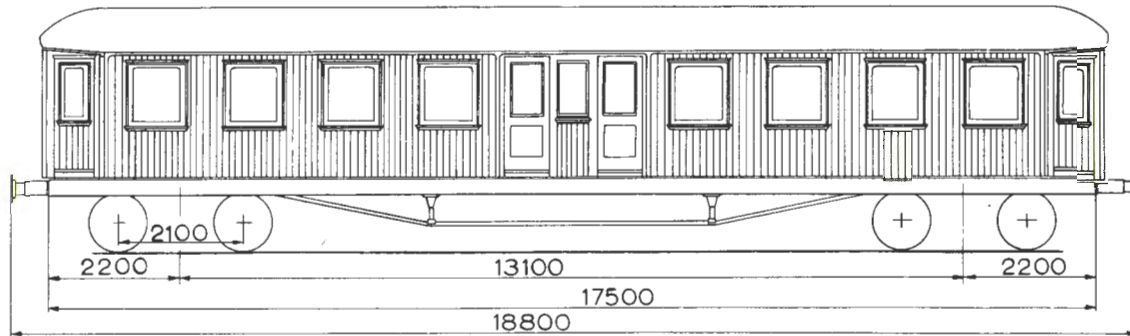

Oppr. hovedt. 2845

Vogn nr.	Distriktsmerke	Fabrikant	Byggeår	Omr. vognvekt i tonn	Sittepl. 2.klasse	Grunnriss	Elvarme i kW	Vognutstyr (se side 6)	Merknad
18118	B	Skb	25	27,0	66			1H.3. 5.11	
18119	"	"	"	27,5	"			1H.3. 5.11	
18120	"	"	"	"	"			1H.3. 5.11.39a	
18121	"	"	26	27,0	"			1H.3. 5.11.39a	
18122	"	"	"	"	"			1H.3. 5.11.39a	
18123.	"	"	"	"	"			1H.3. 5.11.39a	
18124	"	"	"	26,5	"			1H.3. 5.11.39a	

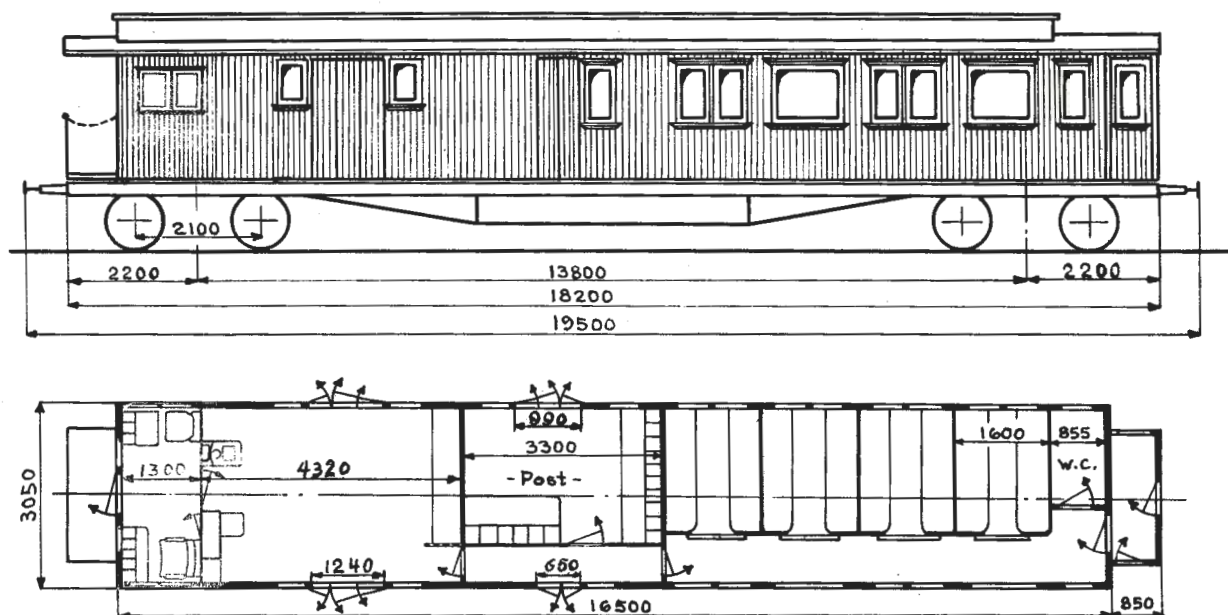

Hovedt. 701

Vogn nr.	Distriktsmerke	Fabrikant	Byggeår	Omtr. vognvekt i tonn	Sittepl. 2.klasse	Post, last i tonn	Reisegods, last i tonn	Grunnriss	El. varme i kW	Vognutstyr (se side 6)	Merknad
963	B	Skb	04	26,5	32	0,5	2,0			1H.3.5.8.11.28.39a	
964	K	"	"	28,5	"	"	"			1H.3.5.7.8.11.39a	

BDFo2-7

TYPE 2

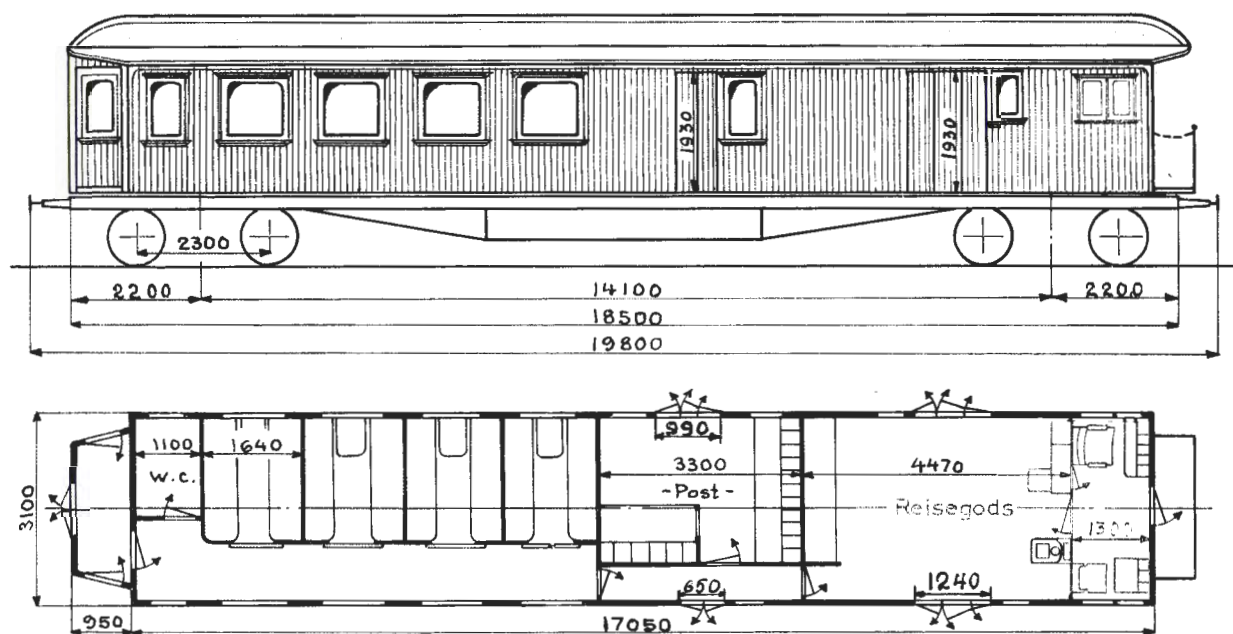

Hovedt. 1928

Vogr nr.	Distriktsmerke	Fabrikant	Byggeår	Omr. vognvekt i tonn	Sittepl. 2.klasse	Post, last i tonn	Reisegods, last i tonn	Grunnriss	El.varme i kW	Vognutstyr (se side 6)	Merknad
18081	B	SJv	21	35,0	32	1,5	3,0			1H.3.5.7.8.11.28.39a	1)
18082	"	"	"	34,5	"	"	"			1H.3.5.7.8.11.28 ²).39a	1)
18083	"	"	"	"	"	"	"			1H.3.5.7.8.11.28 ²).39a	1)
18092	T	"	"	34,0	"	"	"			1H.3.5.7.8.11.28.39a	

1) Innb. plattform i begge vogn-ender

2) Bare i ende ved 2. kl. avd.

Trykk nr. 751 1.7.66

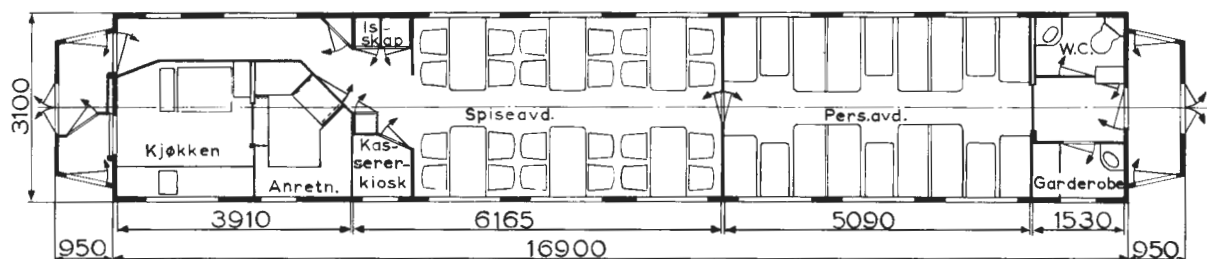
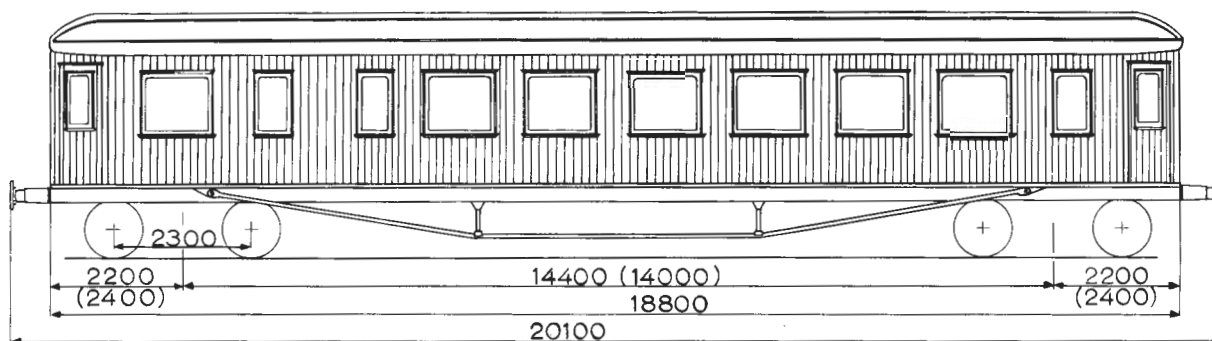
Oppr. hovedt. 2125¹⁾ (4190¹⁾)

Vogn nr.	Distriktmerke	Fabrikant	Byggeår	Omr. vognvekt i tonn	Sittepl. 2.klasse	Grunnriss	El.varme i kW	Vognutstyr (se side 6)	Merknad
772	H	Str	20	33,5	48			1H.3.5.11.28.39a	2)
18039	T	"	16	34,0	"			1H.3.5.11.28.39a	2)
18139	D	Skb	37	"	"			1H.3.12.28.39a	3)
18140	"	"	"	35,0	"			1H.3.12.28.39a	3)

Mål i () gjelder vogn nr. 18139 og 18140

1) Forandr. etter tegn. 6405

2) Koksomfyr og isskap

3) Elektr. komfyr og kjøleskap

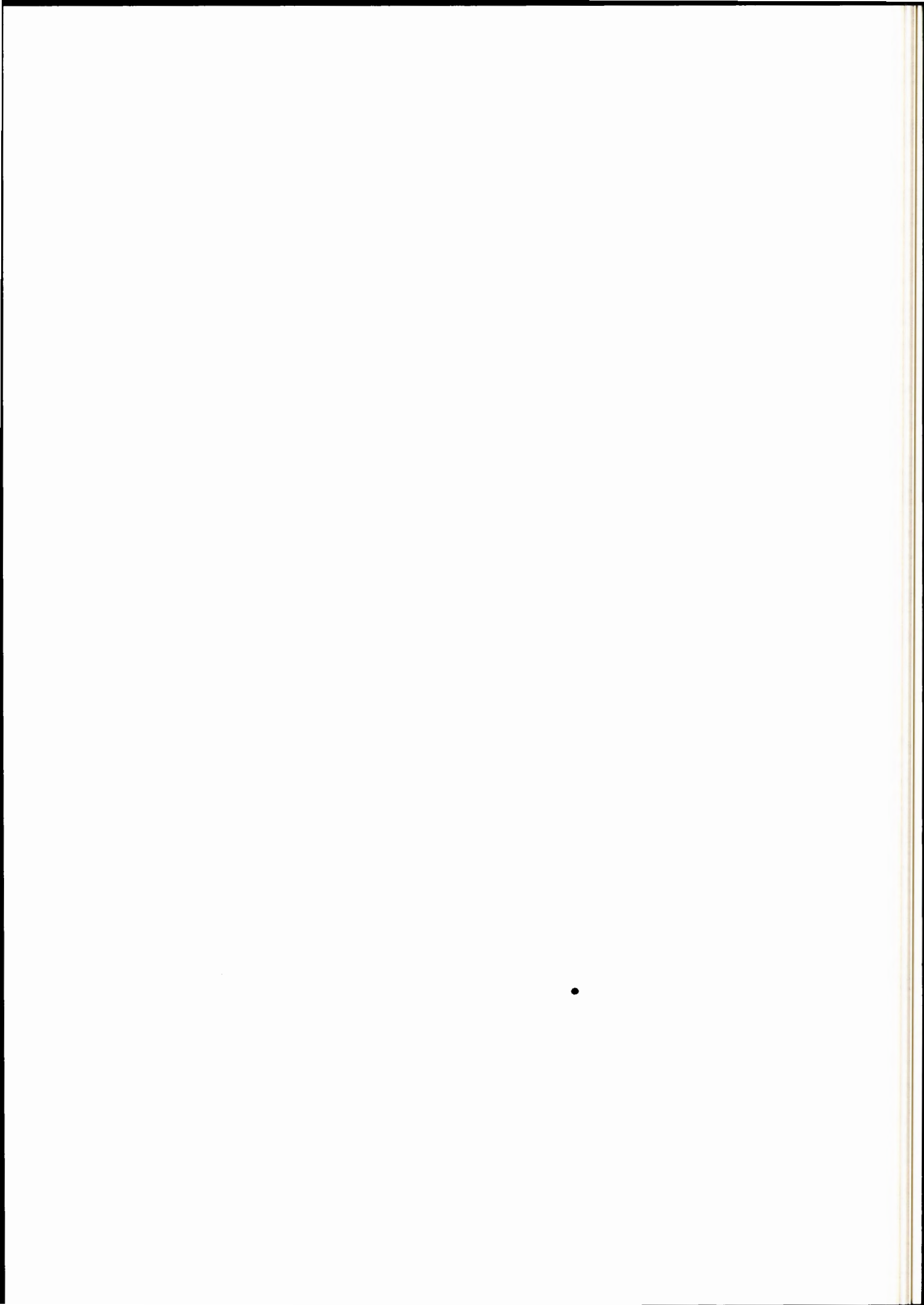

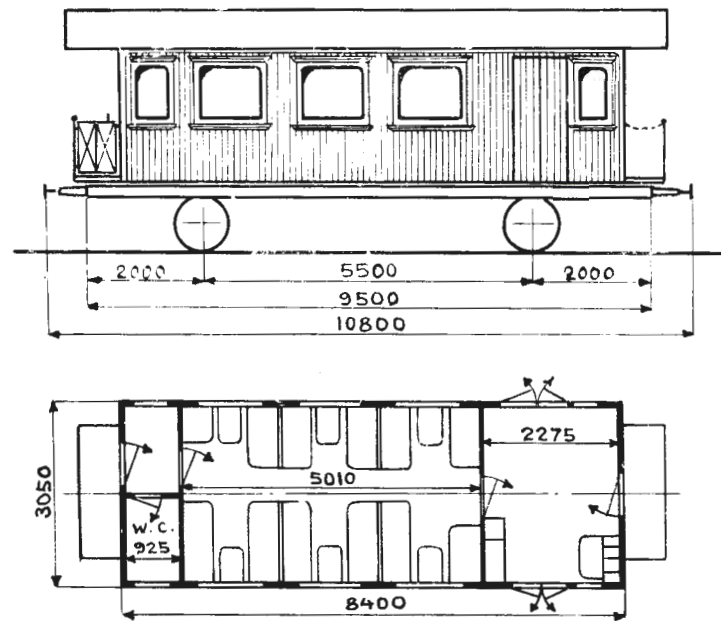
Oppr. hovedt. 1245¹⁾

Vogn nr.	Distriktsmerke	Fabrikant	Byggeår	Omr. vognvekt i tonn	Sittepl. 2.klasse	Reisegods, last i tonn	Grunnriss	El. varme i kW	Vognutstyr (se side 6)	Merknad
697	N	Skb	20	13,5	28	0,5			1W.3.6.7.8.10.24.40	

1) Forandr. etter Krv d. tegn. N 453

BF3b

TYPE 1

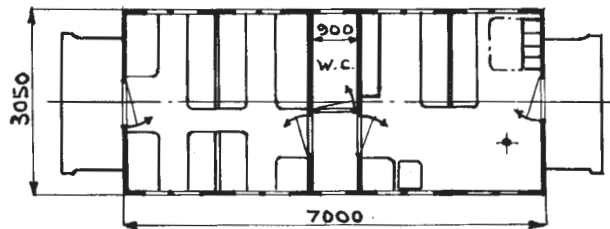
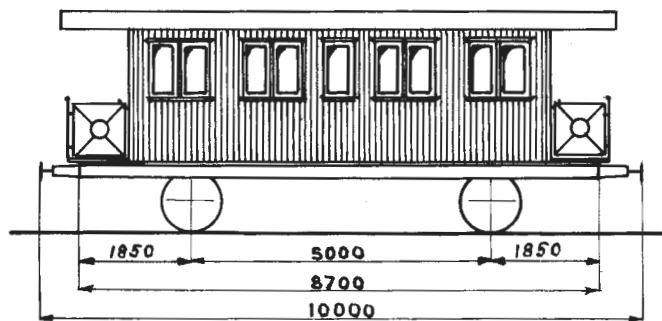

Oppr. hovedt. Valdresbanens nr. 3¹⁾

Vogn nr.	Distriktsmerke	Fabrikant	Byggeår	Omtr. vognvekt i tonn	Sittepl. 2.klasse	Reisegods, last i tonn	Grunnriss	El. varme i kW	Vognutstyr (se side 6)	Merknad
237	0	Sk'b	02	11,0	22	0,5			3.5.7.8.13.15.24	
240	"	"	"	"	"	"			3.5.7.13.15.24	

1) Forandr. etter O.d. M 3874

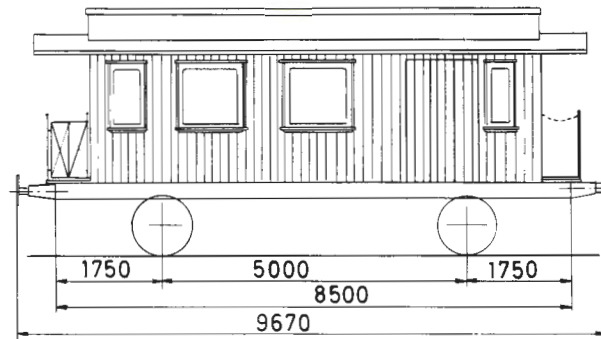

Grunnriss 1

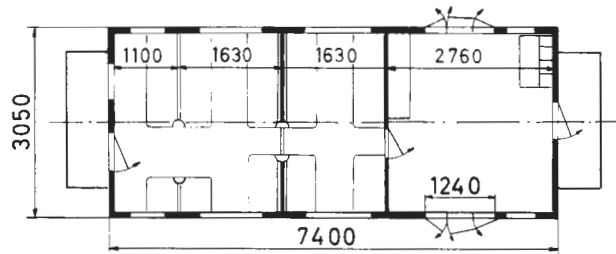

Grunnriss 2¹⁾

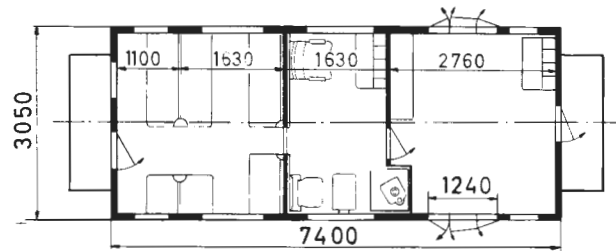

Hovedt. 1209

Vogn nr.	Distriktsmerke	Fabrikant	Byggeår	Omtr. vognvekt i tonn	Sittepl. 2.klasse	Reisegods, last i tonn	Grunnriss	El.varme i kW	Vognutstyr (se side 6)	Merknad
547	D	Str	12	11,5	13	1,0	2		1H. 3.7.8.11.24	
548	"	"	"	11,0	23	"	1		1H. 3. 6.7.8.11.24	
549	K	"	"	11,5	13	"	2		1H. 3. 6.7.8.11.24	

1) Forandr. etter Krs. tegn. K dM. 369

BFo2a

TYPE 3

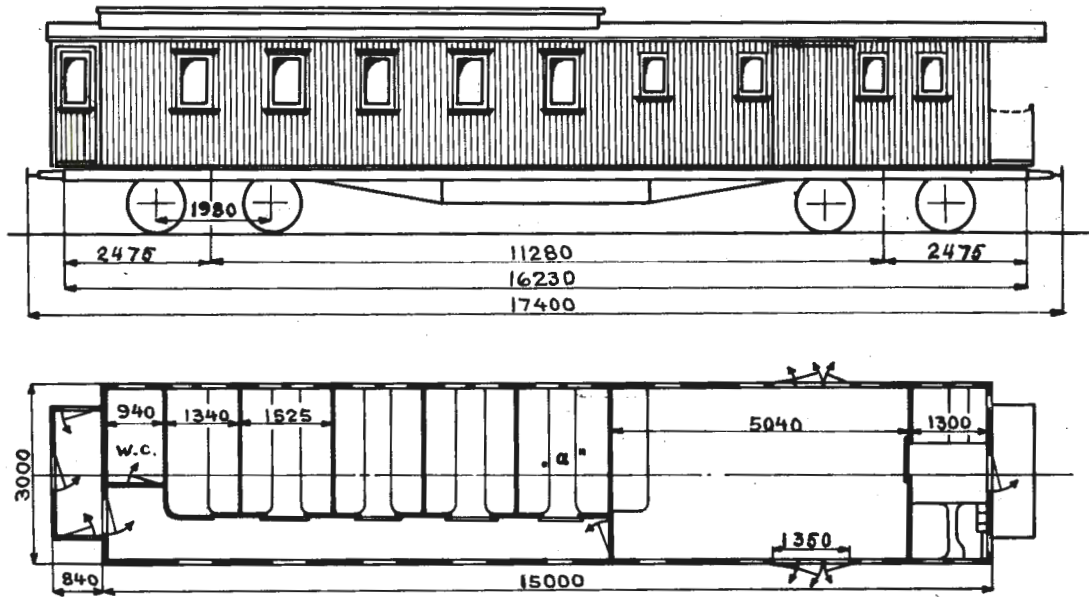

Oppr. hovedt. 369

Vogn nr.	Distriktsmerke	Fabrikant	Byggear	Omtr. vognvekt i tonn	Sittepl. 2.klasse	Reisegods, last i tonn	Grunnriss	El. varme i kW	Vognutstyr (se side 6)	Merknad
805	H	Str	96	22,5	36				1H.3.5.7.8.13	Prov. postkupé "a"

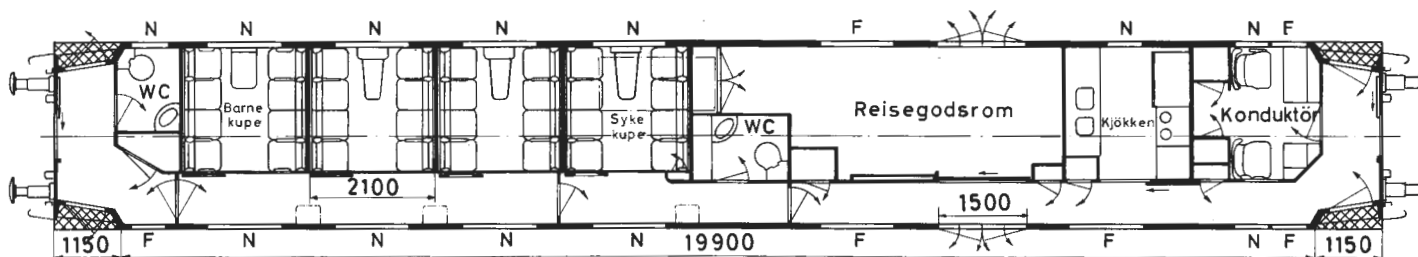
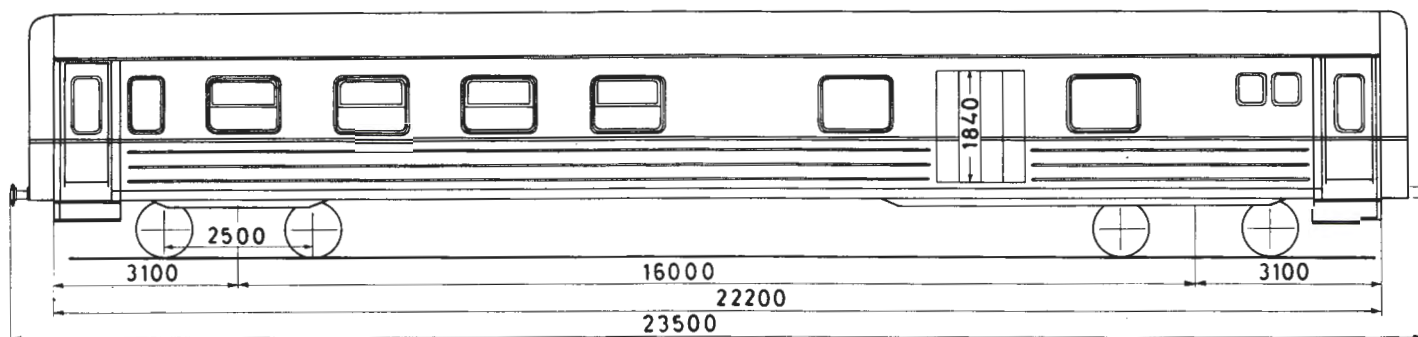

Hovedt.15004

Vogn nr.	Fabrikant	Byggedr	Omr. vognvekt i tonn	Sittepl. 2.kl.	Reisegods, last i tonn	Grunnriss	El. varme i kW	Vognutstyr (se side 6)	Merknad
21515	Str	65	34,5	32	3,0	40	1KEs. 3. 4 b.12. 28. 39a		
21516	"	"	"	"	"	"	1KEs. 3. 4 b.12. 28. 39a		
21517	"	66	"	"	"	"	1KEs. 3. 4 b.12. 28. 39a		
21518	"	"	"	"	"	"	1KEs. 3. 4 b.12. 28. 39a		
21519	"	"	"	"	"	"	1KEs. 3. 4 b.12. 28. 39a		
21520	"	"	"	"	"	"	1KEs. 3. 4 b.12. 28. 39a		
21521	"	"	"	"	"	"	1KEs. 3. 4 b.12. 28. 39a		
21522	"	"	"	"	"	"	1KEs. 3. 4 b.12. 28. 39a		
21523	"	"	"	"	"	"	1KEs. 3. 4 b.12. 28. 39a		
21524	"	"	"	"	"	"	1KEs. 3. 4 b.12. 28. 39a		

BFo2b

TYPE 1

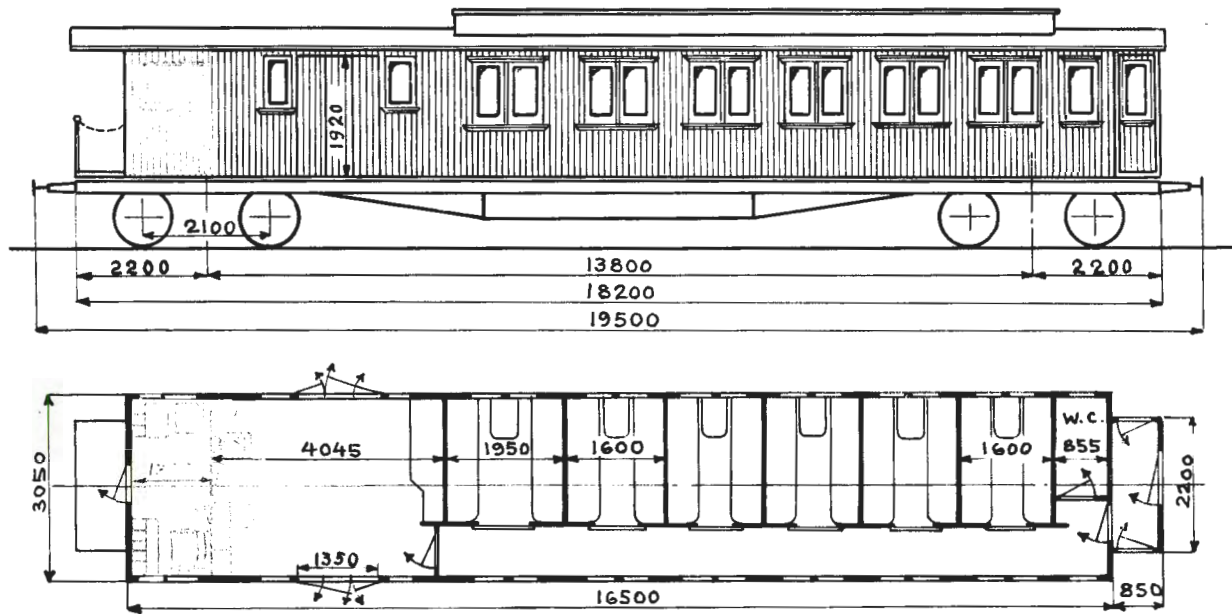

Oppr. hovedt. 702

Vogn nr.	Distriktsmerke	Fabrikant	Byggeår	Omr. vognvekt i tonn	Sittepl. 2.klasse	Reisegods, last i tonn	Grunnriss	El. varme i kW	Vognutstyr (se side 6)	Merknad
965	B	Skb	04	28,0	48	2,0			1H.3.5.8.11.28.39a	

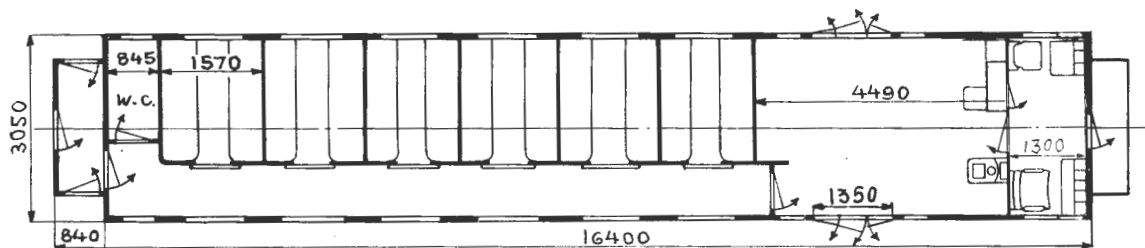
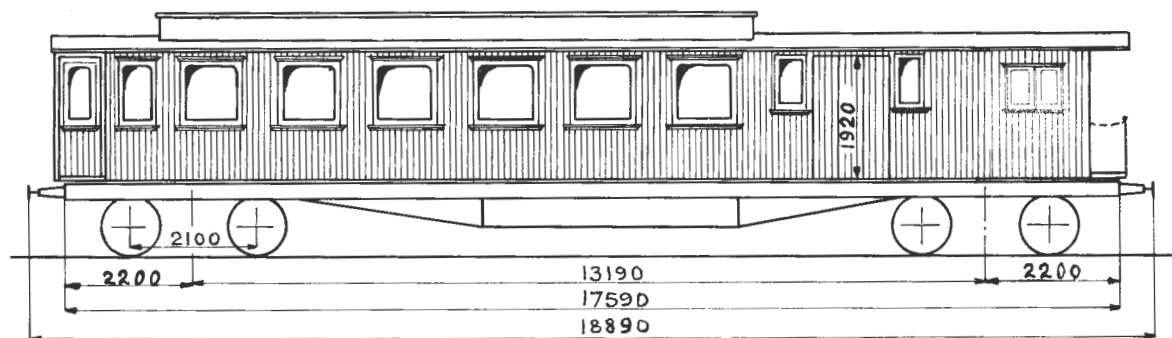

Hovedt. 612

Vogn nr.	Distriktsmerke	Fabrikant	Byggear	Omr. vognvekt i tonn	Sittepl. 2.klasse	Reisegods, last i tonn	Grunnriss	El. varme i kW	Vognutstyr (se side 6)	Merknad
778	H	Skb	09	28,0	48	1,0			1H.3.5.7.8.11.39a	1)
837	T	Str	05	27,0	"	2,0		1H.3.5.7.8.11		

1) Oppr. hovedt. 745

Trykk nr. 751 1.7.66

BFo2b

TYPE 3

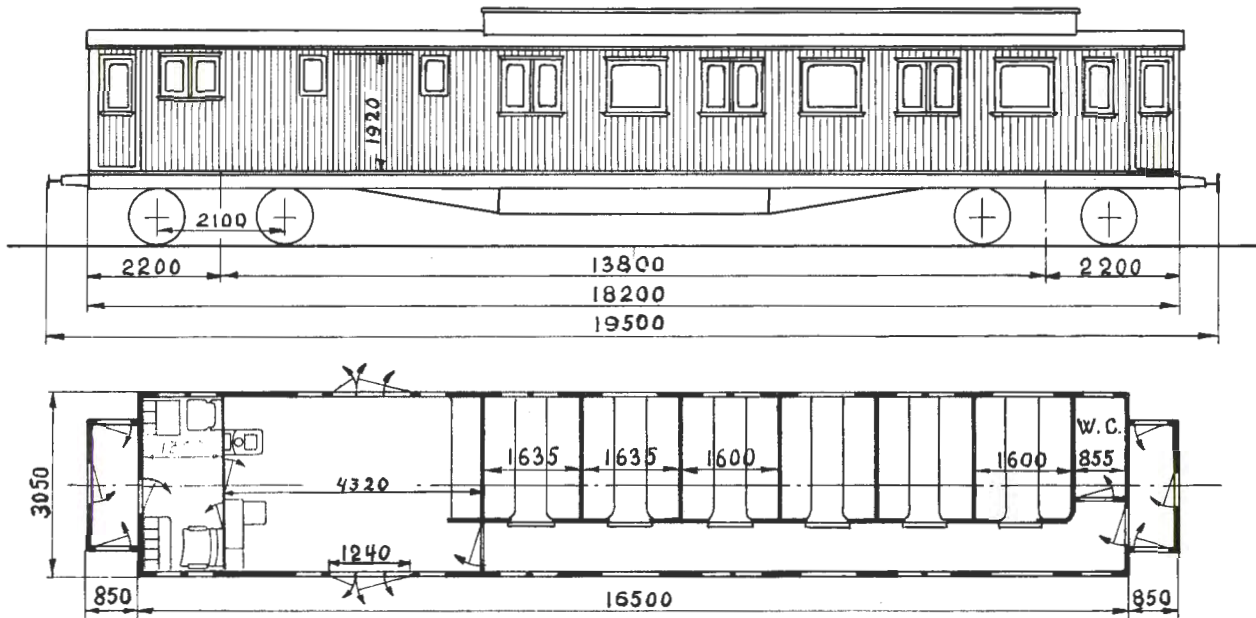

Oppr. hovedt. 701

Vogn nr.	Distriktsmerke	Fabrikant	Byggeår	Omtr. vognvekt i tonn	Sittepl. 2.klasse	Reisegods, last i tonn	Grunnriss	El. varme i kW	Vognutstyr (se side 6)	Merknad
514	D	Skb	09	27,5	48	2,0			1H.3.8.11.28.39a	2)
515	"	Str	"	29,0	"	"			1H.3.8.11.39a	2)
940	B	"	07	"	"	1,5			1H.3.5.8.11.28 ¹⁾ .39a	
941	"	"	08	28,5	"	"			1H.3.5.8.11.28 ¹⁾ .39a	
942	"	"	"	27,0	"	"			1H.3.5.8.11.28.39a	

- 1) Bare i ende ved 2. kl. avd.
 2) Innb. plattform bare i ende ved 2. kl. avd.

Trykk nr. 751 1.7.62

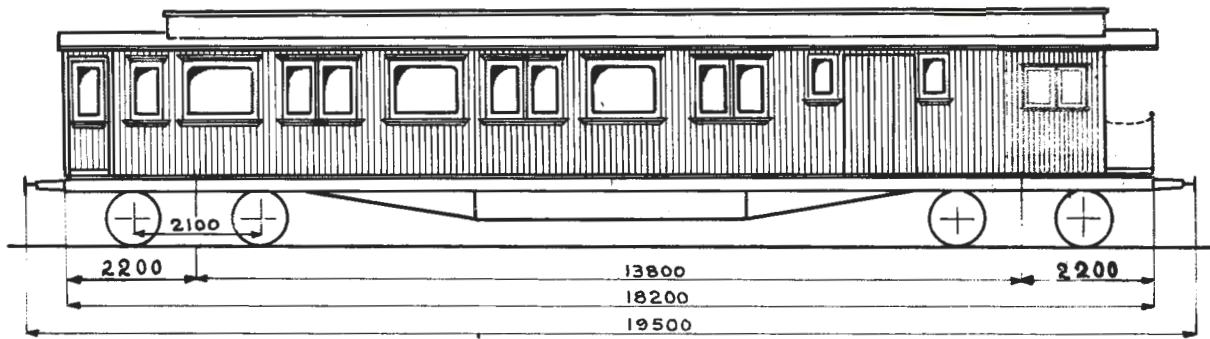

Grunnriss 1

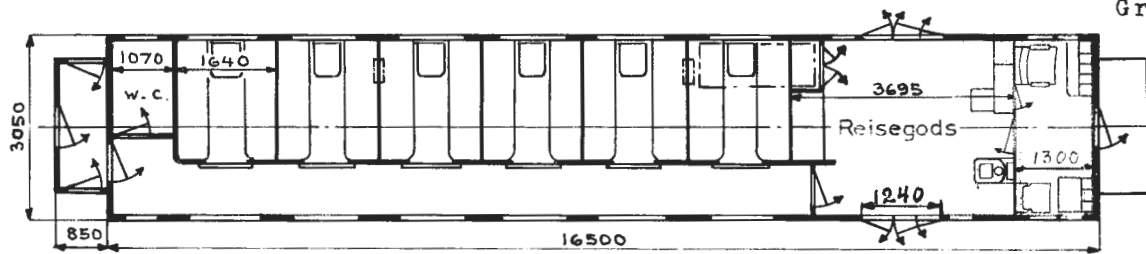

Grunnriss 2

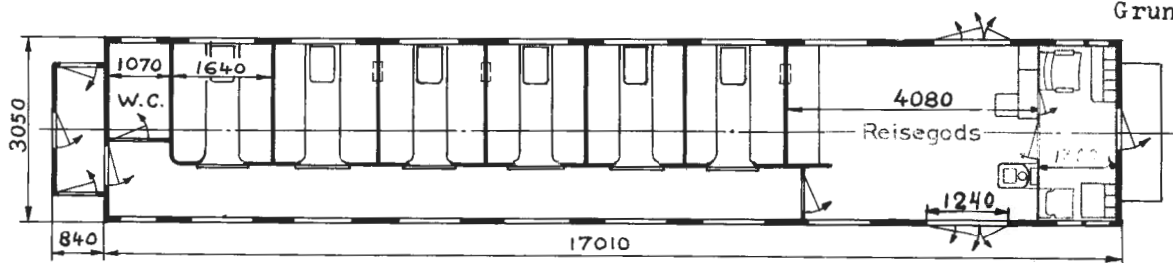

Hovedt. gr.riss 1: 1073
" 2: 1074

Vogn nr.	Distriktsmerke	Fabrikant	Byggeår	Omtr. vognvekt i tonn	Sittepl. 2.klasse	Reisegods, last i tonn	Grunnriss	El. varme i kW	Vognutstyr (se side 6)	Merknad
545	D	Skb	11	28,0	48	1,5	1		1H.3.5.8.11.28.39a	1)
779	H	"	10	31,0	"	"	2		1H.3.5.7.8.11.39a	
812	T	"	11	30,0	"	"	"		1H.3.5.7.8.11.39a	
977	B	"	10	"	"	"	1		1H.3.5.8.11.39a	

1) Har ikke sykekupé

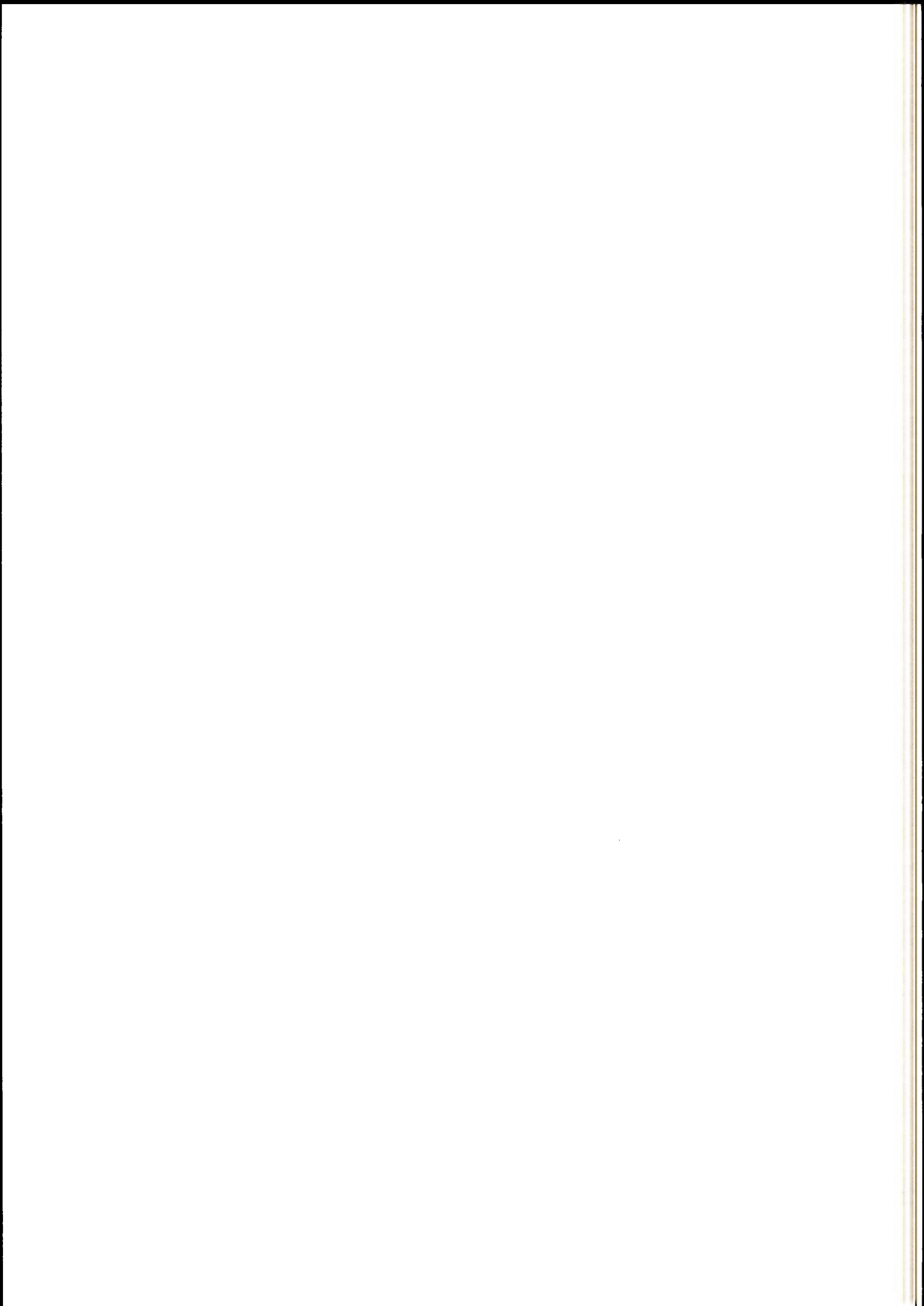

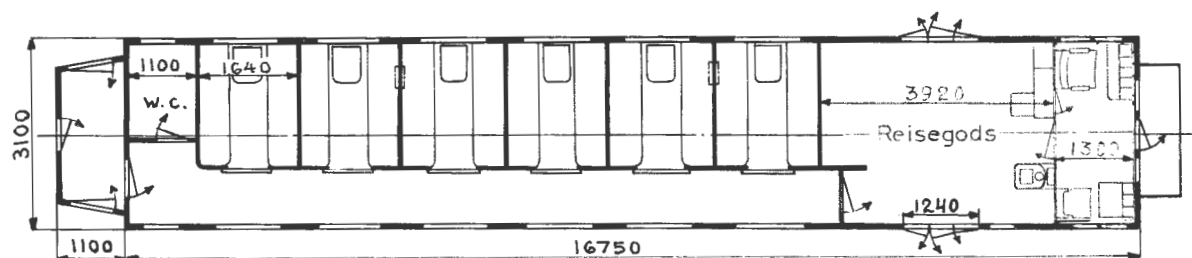
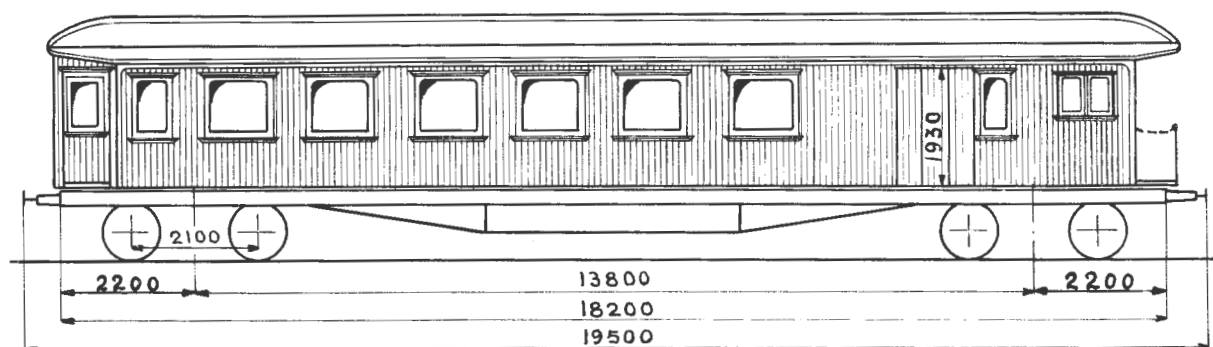

Hovedt. 2061

Vogn nr.	Distriktsmerke	Fabrikant	Byggear	Omr. vognvekt i tonn	Sittepl. 2.klasse	Reisegods, last i tonn	Grunnriss	El. varme i kW	Vognutstyr (se side 6)	Merknad
815	T	Skb	13	31,0	48	2,0			1H.3.5.7.8.11.39a	1)
18001	"	"	"	29,5	"	"			1H.3.5.8.11.39a	

1) Sykekupé med inng. fra reisegodsrom

Trykk nr. 751 1.7.62

BFo2b

TYPE 6

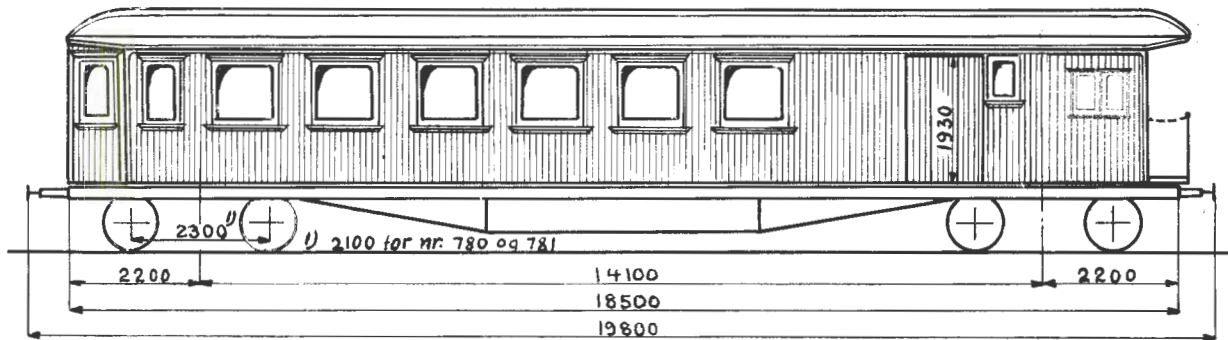

Grunnriss 1

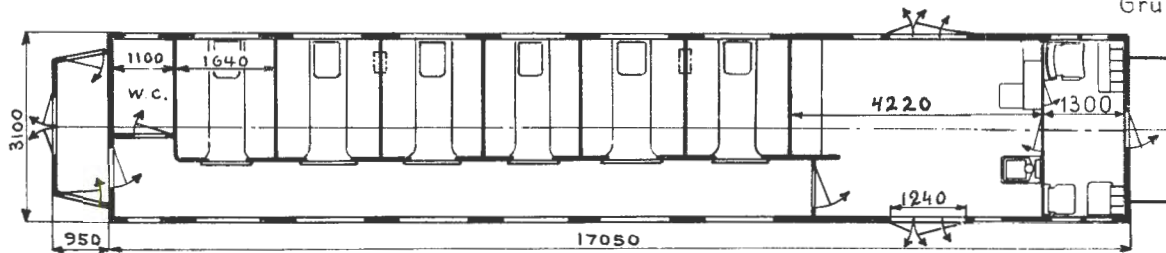

Grunnriss 2

Hovedt. gr.riss 1: 1841
" 2: 3109

Vogn nr.	Distriktsmerke	Fabrikant	Byggeår	Omr. vognvekt i tonn	Sittepl. 2.klasse	Reisegods, last i tonn	Grunnriss	El. varme i kW	Vognutstyr (se side 6)	Merknad
183	O	Str	17	32,5	48	3,0	2		1H.3.5.8.11.28.39a	1)5)
575	D	"	15	32,0	"	"	"		1H.3.8.11.28.39a	1)
576	K	"	"	33,5	"	"	"		1H.3.5.7.8.11.39a	1)
577	D	"	"	31,5	"	"	1		1H.3.8.11.28.39a	
578	"	"	"	32,5	"	"	"		1H.3.7.8.11.28.39a	
649	"	"	29	33,0	"	"	2		1H.3.5.8.11.28.39a	
650	"	"	"	"	"	"	"		1H.3.5.8.11.28.39a	
776	H	"	21	32,0	"	"	"		1H.3.5.8.11.28.39a	1)
780	"	Skb	13	31,5	"	2,0	1		1H.3.5.7.8.11.39a	3)
781	"	"	"	31,0	"	"	"		1H.3.5.7.8.11.39a	3)

1) Oppr. hovedt. 1841
3) " " 2060
5) Kond.rom utv. til 1800 mm
Trykk nr. 751 1.7.66

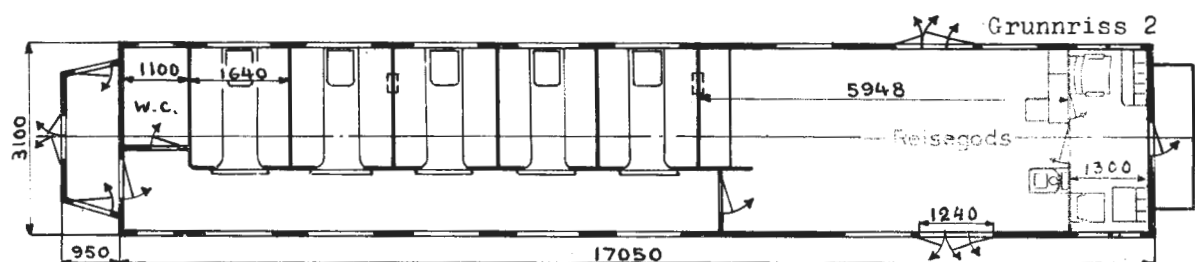
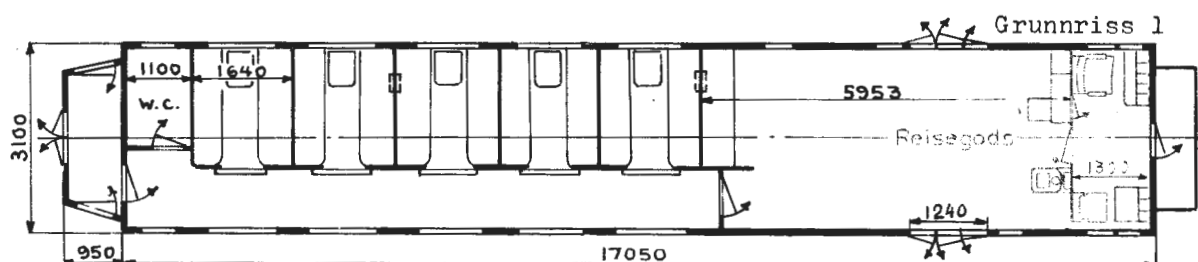
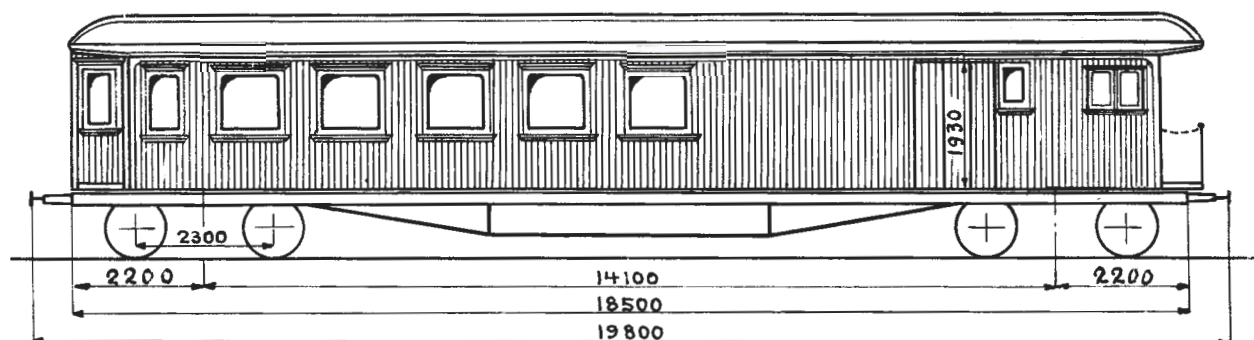

Hovedt. gr.riss 1: 2126
" 2: 2126, 3053

Vogn nr.	Distriktsmerke	Fabrikant	Byggear	Omr. vognvekt i tonn	Sittepl. 2.klasse	Reisegods, last i tonn	Grunnriss	El. varme i kW	Vognutstyr (se side 6)	Merknad
188	0	Str	25	30,5	40	4,0	2		1H.3.5.8.11.39a	1)
296	"	"	16	31,0	"	"	1		1H.3.8.11.39a	1)
647	D	"	27	32,5	"	"	2		1H.3.5.8.11.28.39a	
648	"	"	"	33,0	"	"	"		1H.3.5.7.8.11.28.39a	
879	0	"	17	31,0	"	"	1		1H.3.8.12.28.39a	
888	"	Skb	16	32,0	"	"	"		1H.3.5.8.11.39a	1)
18015	D	"	15	33,0	"	"	"		1H.3.5.7.8.11.28.39a	2)

- 1) Sykekupé med inng. fra reisegodsrom
2) Utvidet forgang

BFo2 c

TYPE 3

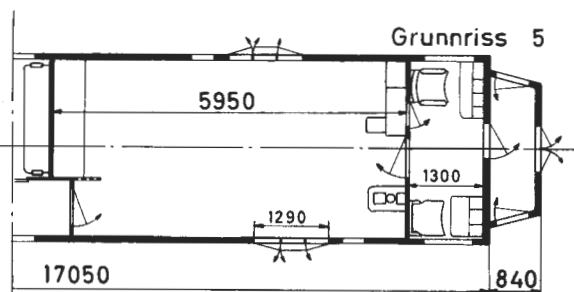
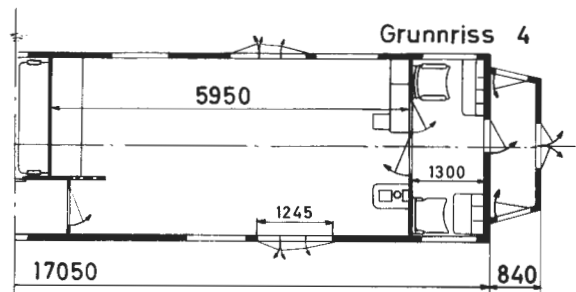
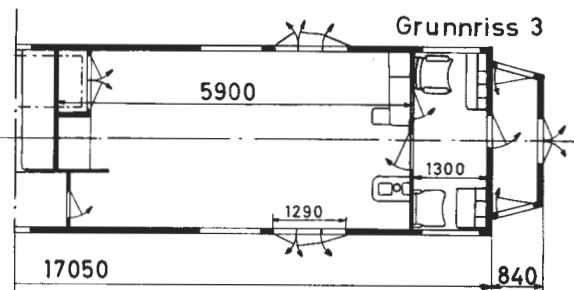
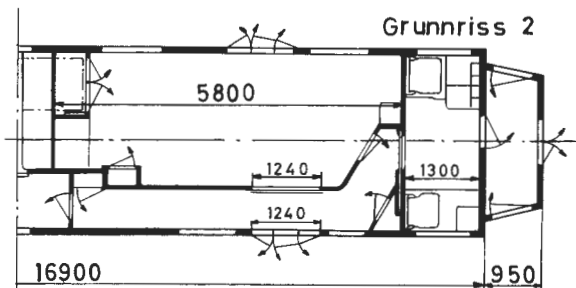
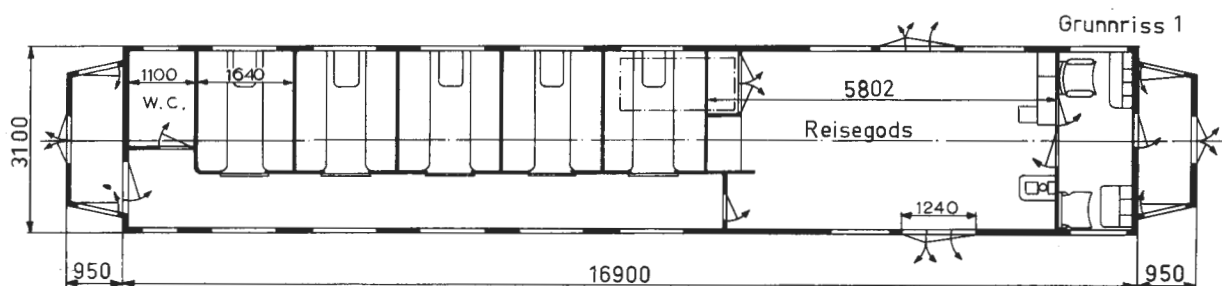
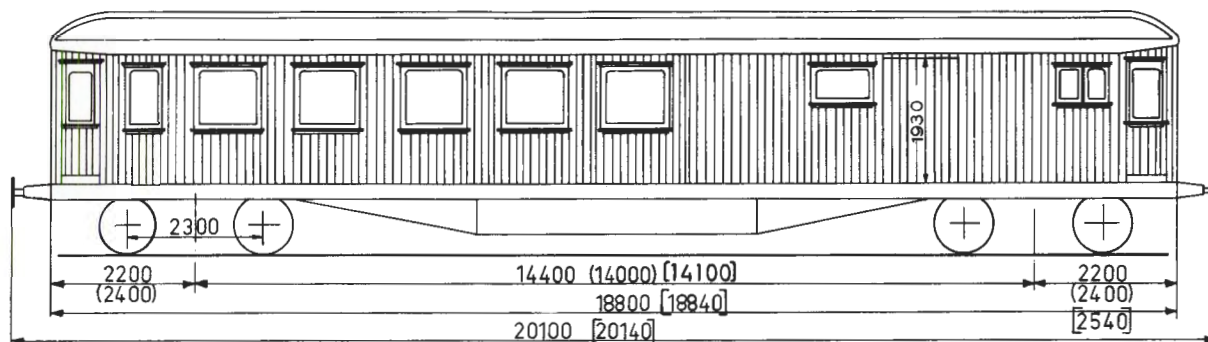

Hovedt. gr.riss 1: 3039, gr.riss 2: 3231
 Oppr. hovedt. " " 3: 1841, " " 4: 2126 og 3053, gr.riss 5: 2126.

Vogn nr.	Distriktsmerke	Fabrikant	Byggeår	Omr. vognvekt i tonn	Sittepl. 2 klasse	Reisegods, last i tonn	Grunnriss	El. varme i kW	Vognutstyr (se side 6)	Merknad
97	0	Str	23	31,5	40	4,0	4		1H. 3. 8. 11. 28. 39a	
98	"	"	"	33,0	"	"	"		1H. 3. 5. 8. 11. 28. 39a	
120	"	"	28	"	"	"	"		1H. 3. 5. 8. 11. 28. 39a	

Mål i () gjelder for gr.riss 2
 " [] " " " " 3,4 og 5

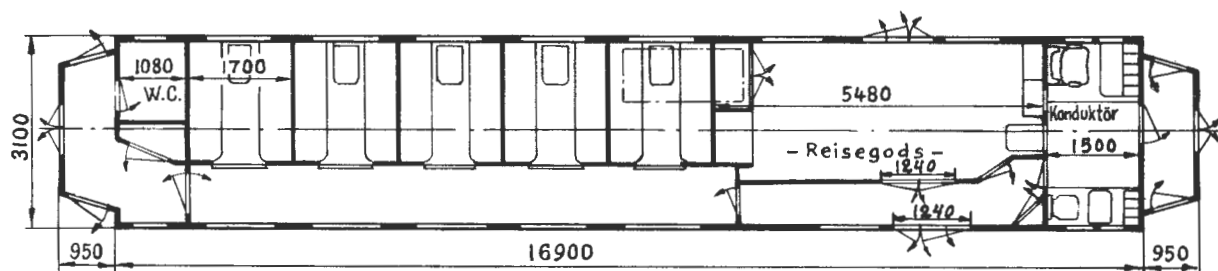
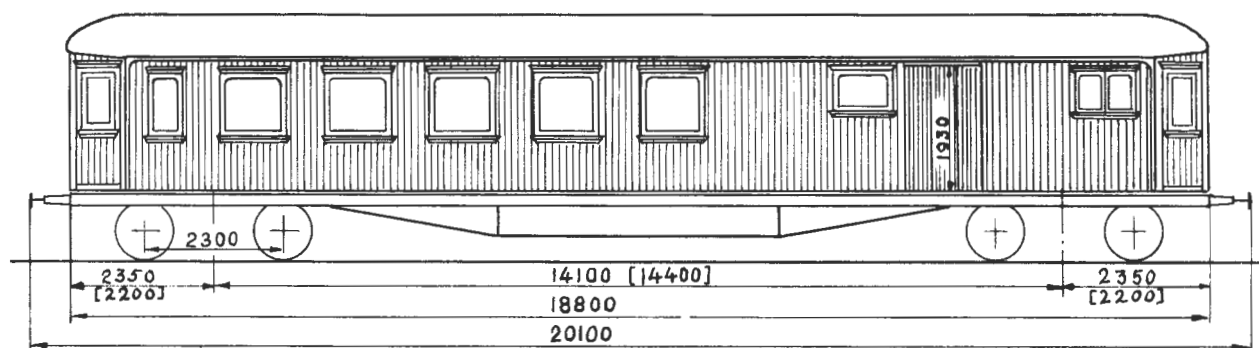

Oppr. hovedt. 1843¹⁾
2126¹⁾

Vogn nr.	Distriktsmerke	Fabrikant	Byggeår	Omr. vognvekt i tonn	Sittepl. 2.klasse	Reisegods, last i tonn	Grunnriss	El. varme i kW	Vognutstyr (se side 6)	Merknad
632	D	Skb	23	33,0	40				1H.3.5.8.11.28.39a	
784	H	Str	17	33,5	"	4,0			1H.3.5.8.11.28.39a	

Mål i () gjelder vg. nr. 632

1) Forandr. etter tegn. 6263

Trykk nr. 751 1.7.60

BFo2d

TYPE 1
Stålvogner

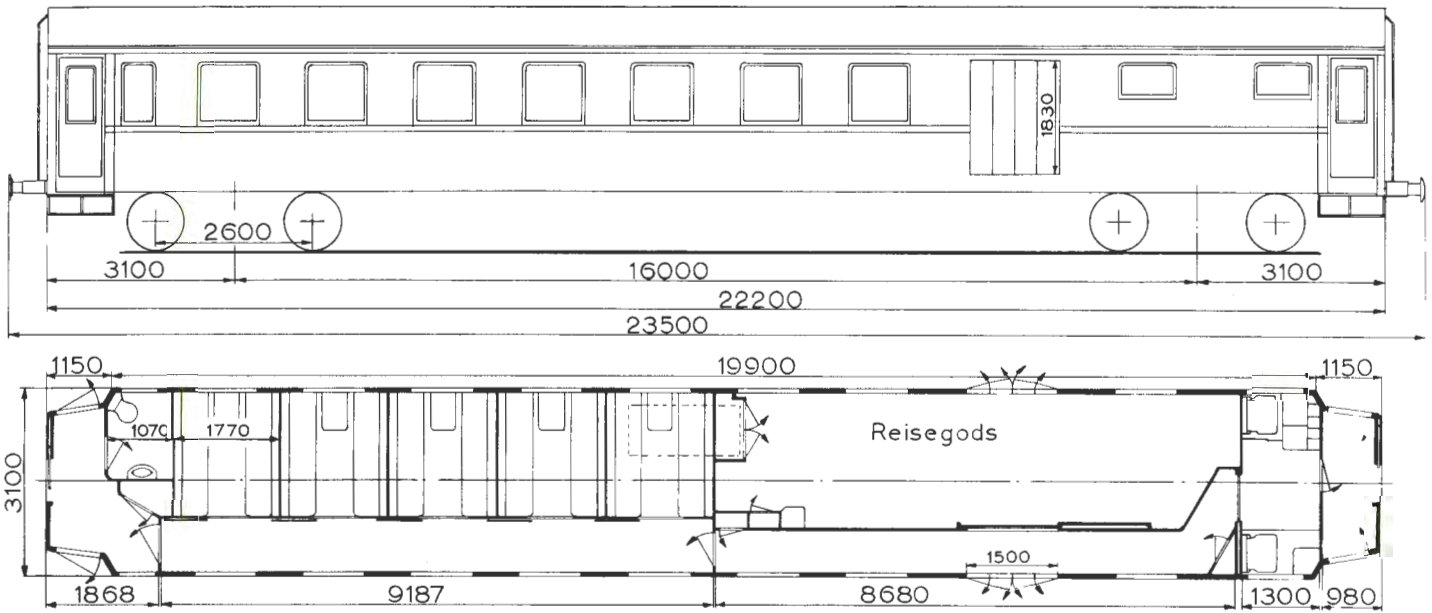

Hovedt. 4100

Vogn nr.	Distriktsmerke	Fabrikant	Byggear	Omtr. vognvekt i tonn	Sittepl. 2. klasse	Reisegods, last i tonn	Grunnriss	El. varme i kW	Vognutstyr (se side 6)	Merknad
21501	O	Skb	38	36,5	40	4,0	23	1H. 3. 5. 11. 28. 39a	1)	
21503	=	"	"	37,5	"	"	"	1H. 3. 5. 11. 28. 39a	1)	

1) Barnekupé

Trykk nr. 751 1.7.66

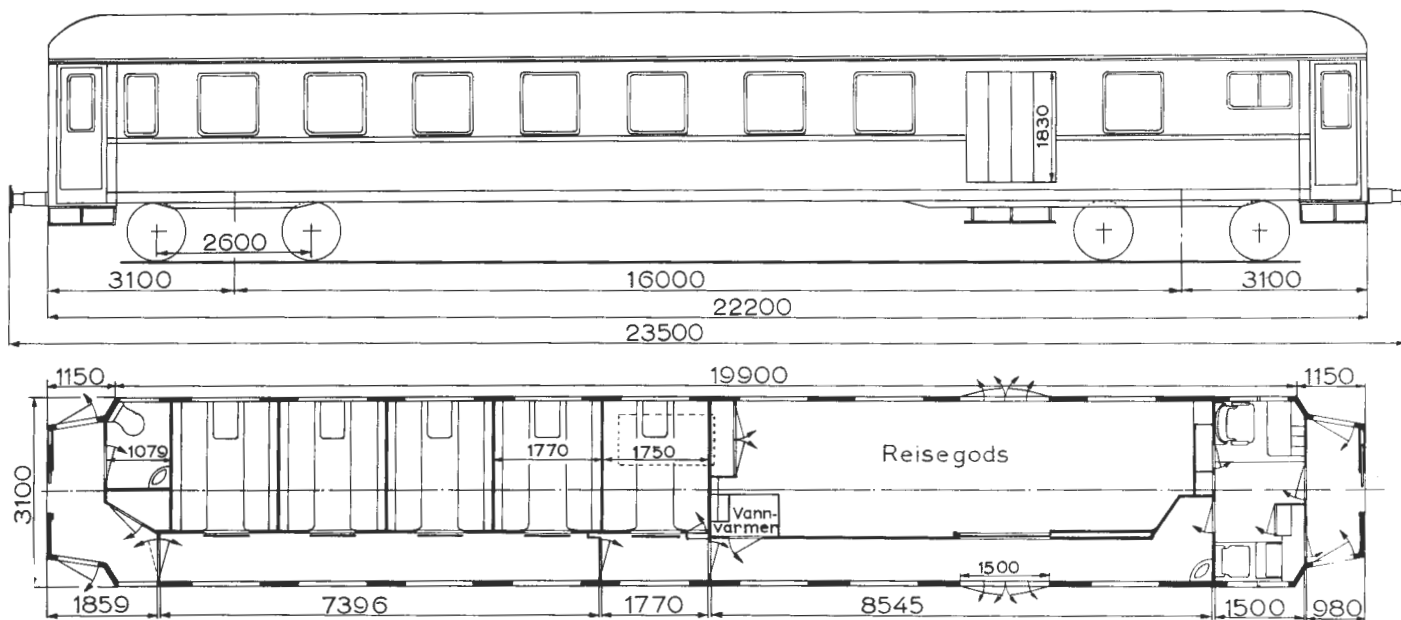

Hovedt. 6490

Vogn nr.	Distriktsmerke	Fabrikant	Byggeår	Omr. vognvekt i tonn	Sittepl. 2. klasse	Reisegods, last i tonn	Grunnriss	El. varme i kW	Vognutstyr (se side 6)	Merknad
21504	O	Str	55	38,0	40	4,0	28	1H. 3. 5. 11. 28. 39a	1)	
21505	"	"	"	38,5	"	"	"	1H. 3. 5. 11. 28. 39a	1)	
21506	"	"	"	37,0	"	"	"	1Hs. 3. 5. 11. 28. 39a	1)	
21508	"	"	"	38,0	"	"	"	1Hs. 3. 5. 11. 28. 39a	1)	
21509	"	"	"	38,5	"	"	"	1Hs. 3. 5. 11. 28. 39a	1)	
21510	"	"	"	38,0	"	"	"	1Hs. 3. 5. 11. 28. 39a	1)	
21511	D	"	"	37,0	"	"	30	1Hs. 3. 12 28 39a	1)	
21513	"	"	"	"	"	"	"	1Hs. 3. 12. 28. 39a	1)	
21514	"	"	"	"	"	"	"	1Hs. 3. 12. 28. 39a	1)	

1) Barnekupe

BFo2dk

TYPE 1

Stålvogner

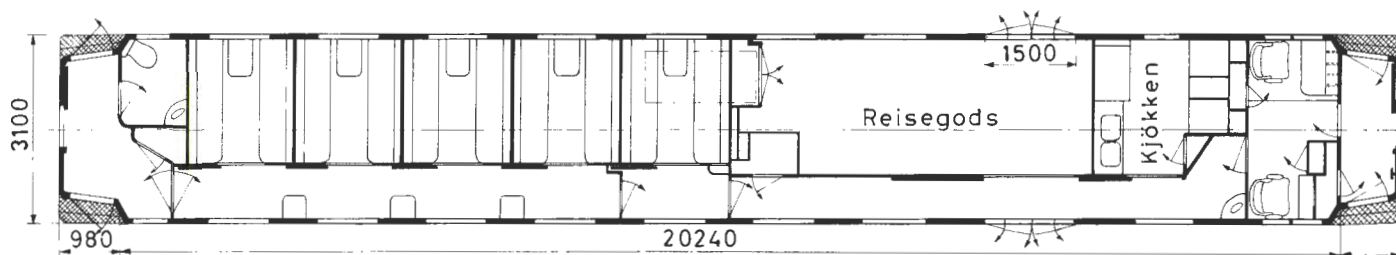
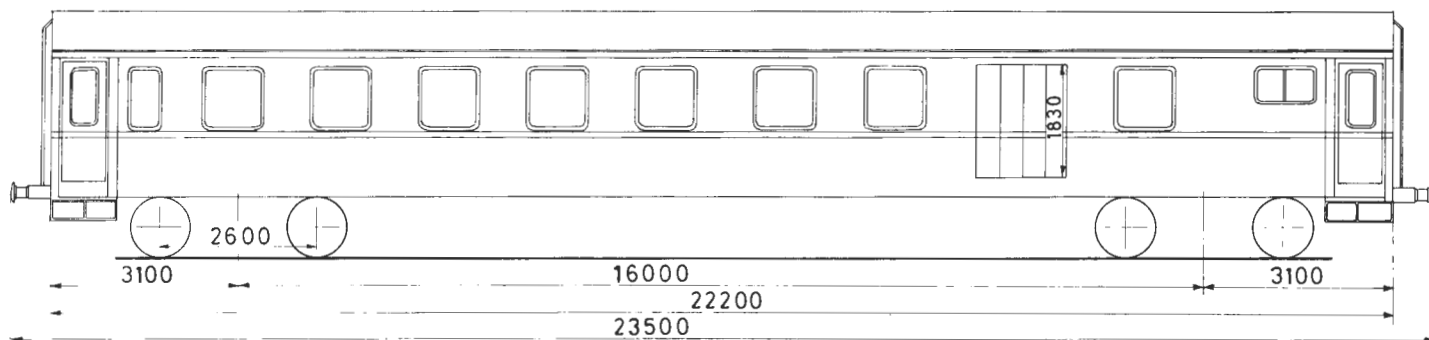

Oppr. hovedt. 4100 1)

Vogn nr.	Distriktsmerke	Fabrikant	Byggeår	Omtr. vognvekt i tonn	Sittepl. 2. klasse	Reisegods, last i tonn	Grunnriss	El. varme i kW	Vognutstyr (se side 6)	Merknad
21502	0	Skb	38	37,5	40	3,0			1H.3.5.11. 28.39a.99	2)

1) Forandr. etter tegn. 15646

2) Barnekupe

BFo 2 dk

TYPE 2

Stålvogner

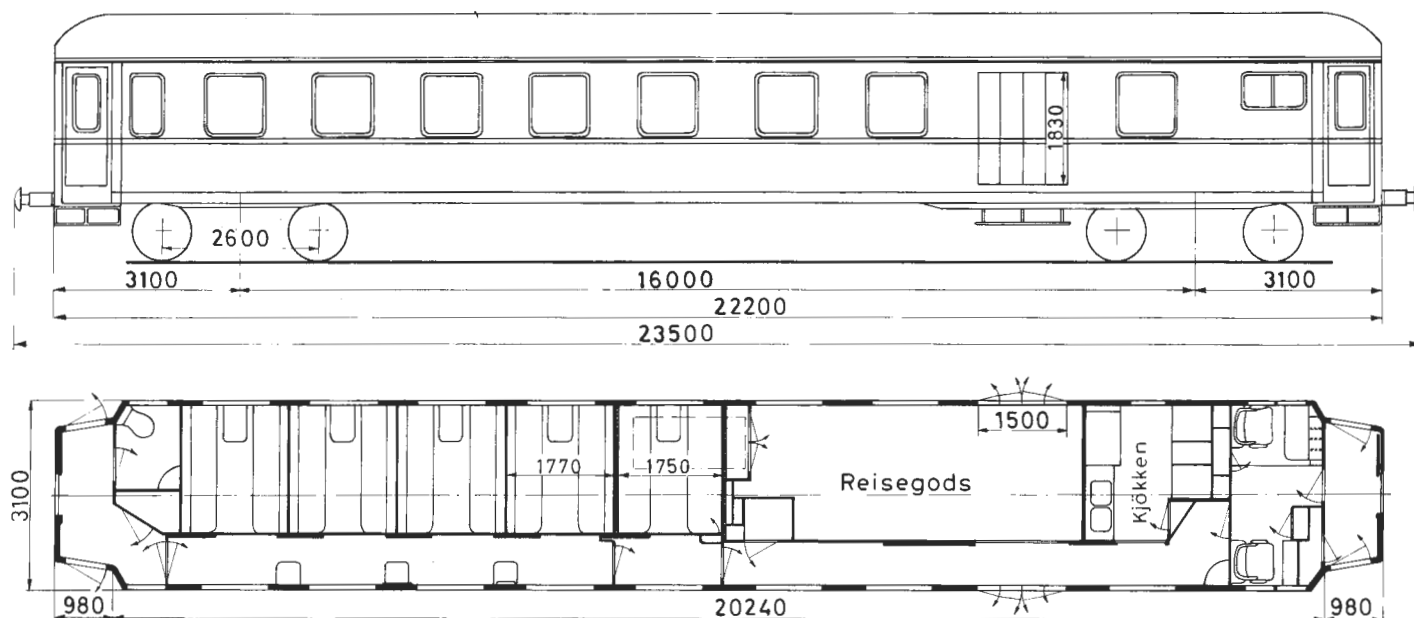

Oppr. hovedt. 6490 1)

Vogn nr.	Distriktsmerke	Fabrikant	Byggeår	Omr. vognvekt i tonn	Sittepl. 2. klasse	Reisegods, last i tonn	Grunnriss	El. varme i KW	Vognutstyr (se side 6)	Merknad
21507	O	Str	55	37,5	40	3,0		28	1Hs.3.5.11.28.39a	2)
21512	D	"	"	36,0	"	"		30	1Hs.3.12.28.39a	2)

1) Forandr. etter tegn. 15645

2) Barnekupe

BFo3a

TYPE 2

Trevogner med platekledning

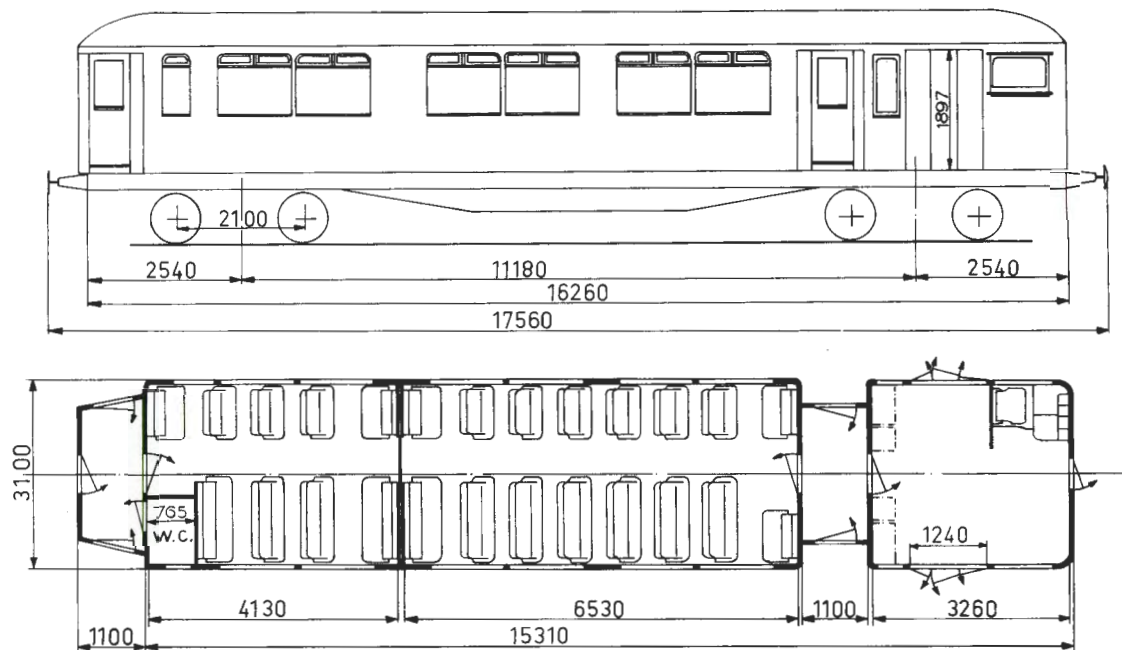

Oppr.hovedt.B.65¹⁾

Vogn nr.	Distriktsmerke	Fabrikant	Byggeår	Omr. vognvekt i tonn	Sittepl. 2.klasse	Reisegods, last i tonn	Grunnriss	El.varme i kW	Vognutstyr (se side 6)	Merknad
67	T	Str	99	24,0	61	1,0			1H.3.5.11.41	Tilhenger for motorvogn

1) Ny vognkasse i 1933 etter tegn. 3405

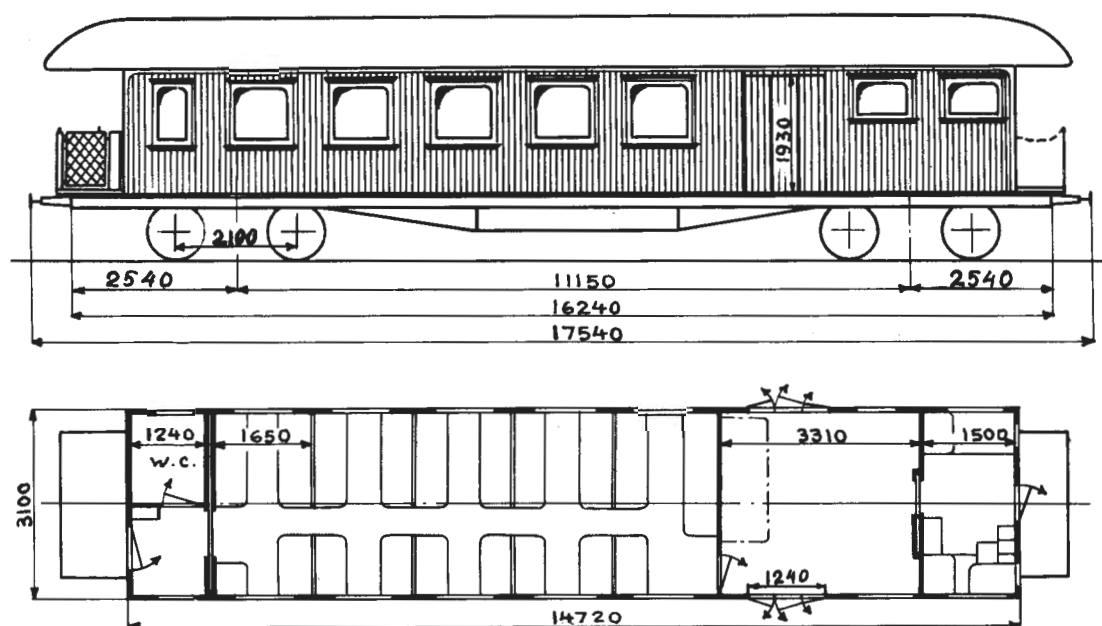

Hovedt. B. 529

Vogn nr.	Distriktsmerke	Fabrikant	Byggeår	Omt. vognvekt i tonn	Sittepl. 2.klasse	Reisegods, last i tonn	Grunnriss	El. varme i kW	Vognutstyr (se side 6)	Merknad
9 0	Skb	97	28,0	48	2,0				1H.3.5.11.39a	

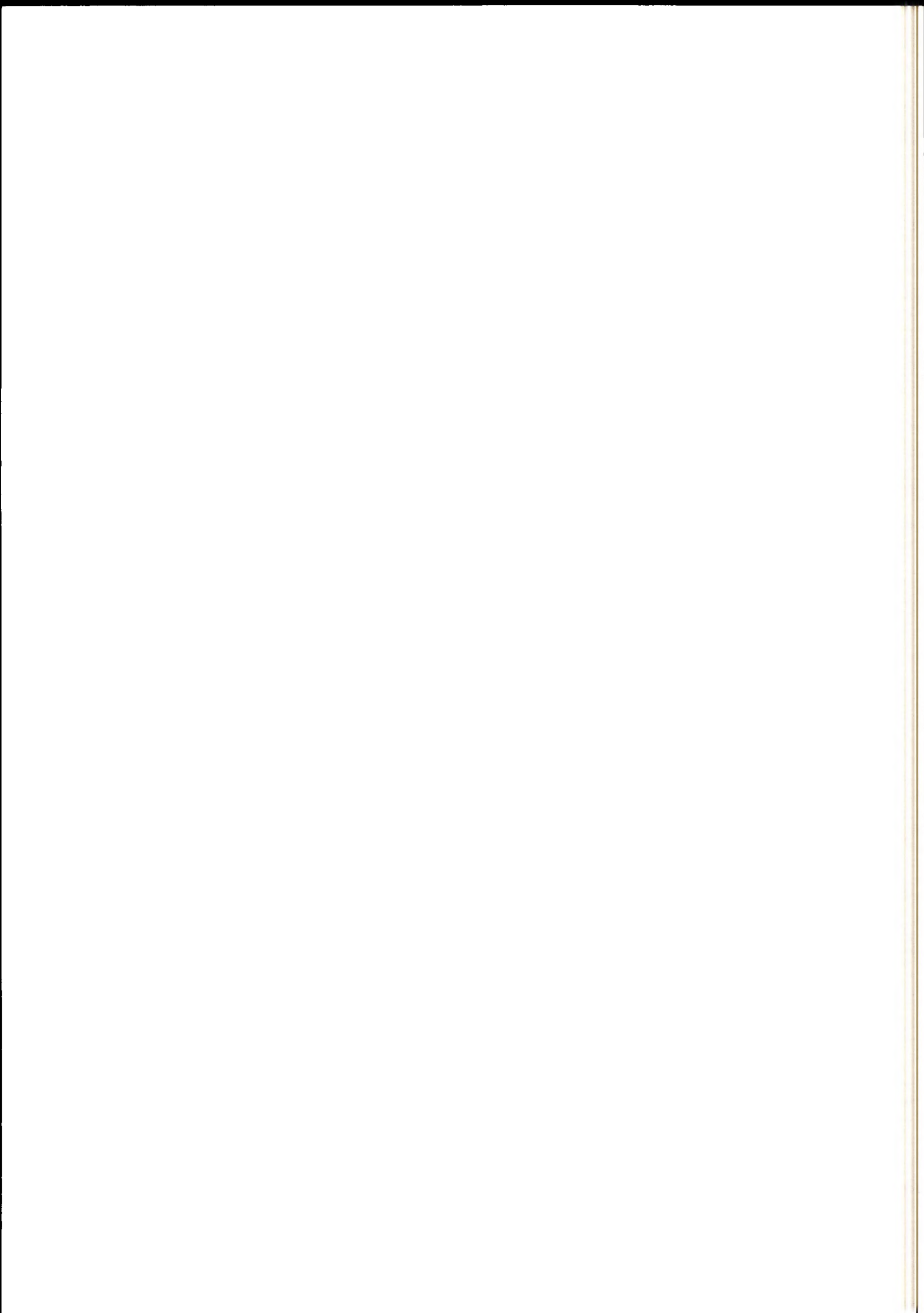

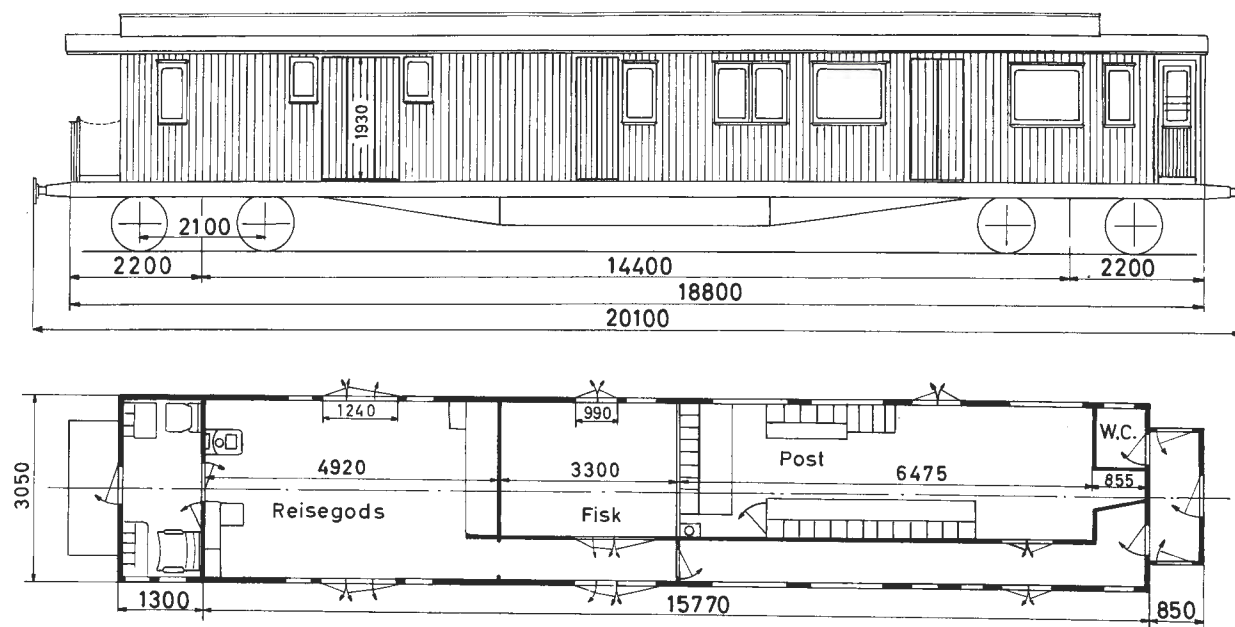

Hovedt. 1)

Vogn nr.	Distriktsmerke	Fabrikant	Byggedr	Omr. vognvekt i tonn	Post, last i tonn	Reisegods, last i tonn	Grunnriss	Elvarme i kW	Vognutstyr (se side 6)	Merknad
512	D	Str	09	29,0	2,0	2,0 ²⁾			1H.3.8.11.28.39a.99	
513	"	"	"	30,5	"	"			1H.3.8.11.28.39a.99	

1) Oppr. BDFo etter hovedt. 989
 Senere DFZo " " 4067
 1962 DFo i.h.t. Hst.jnr. 3531/12

2) Herav i fiskerom 0,5t

DFo-22

TYPE 2

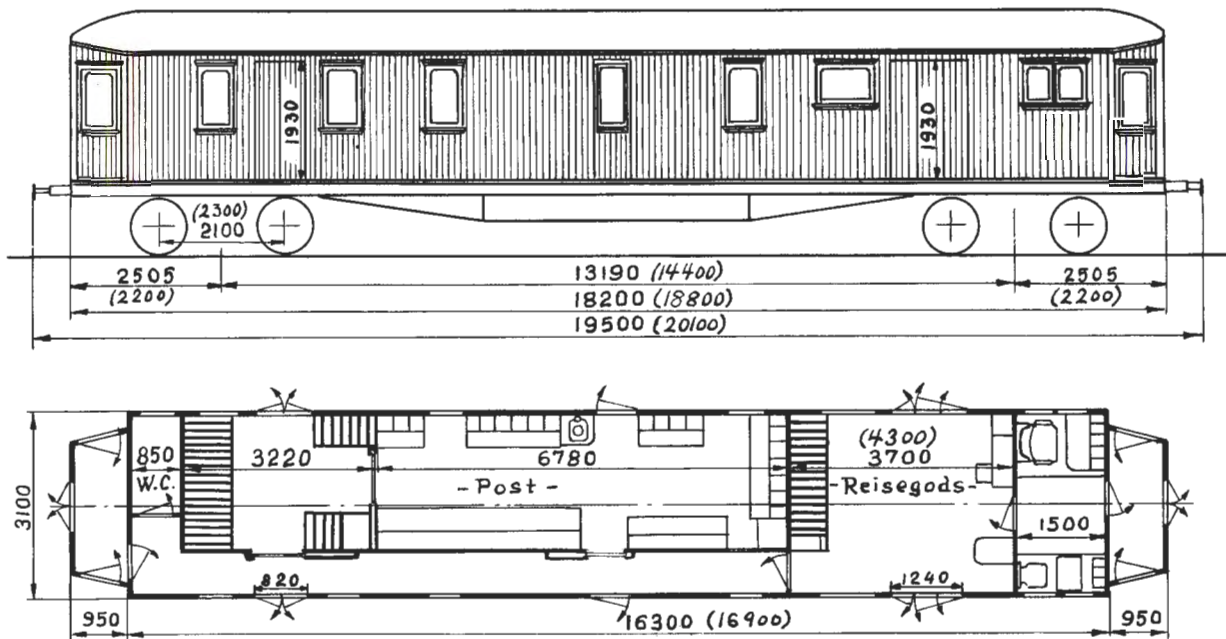

Oppr. hovedt. 439¹⁾

Vogn nr.	Distriktsmerke	Fabrikant	Byggeår	Omr. vognvekt i tonn	Post, last i tonn	Reisegods, last i tonn	Grunnriss	El. varme i kW	Vognutstyr (se side 6)	Merkeid
912	0	Str	01	29,5	4,5	2,5			1H.3.5.8.11.39a	2)
18038	T	"	16	31,0	"	"			1H.3.5.8.11.28 ³⁾ .39a	2) 4)

Mål i () gjelder vg. nr. 18038

1) Forandret etter tegn. 5948

2) Ny vognkasse i 1948

3) Bare i ende ved kond.rom

4) Vognkasse fra vg. nr. 911 montert på understilling til vg. nr. 18038. Forandret etter B.V. skisse nr. 1047

Trykk nr. 751 1.7.66

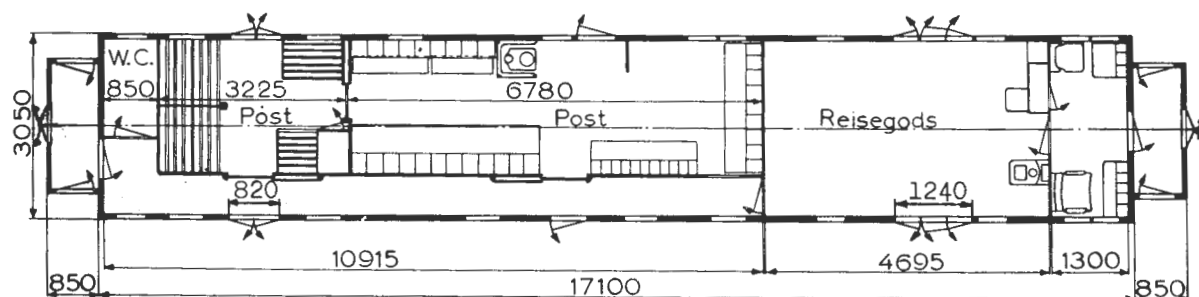
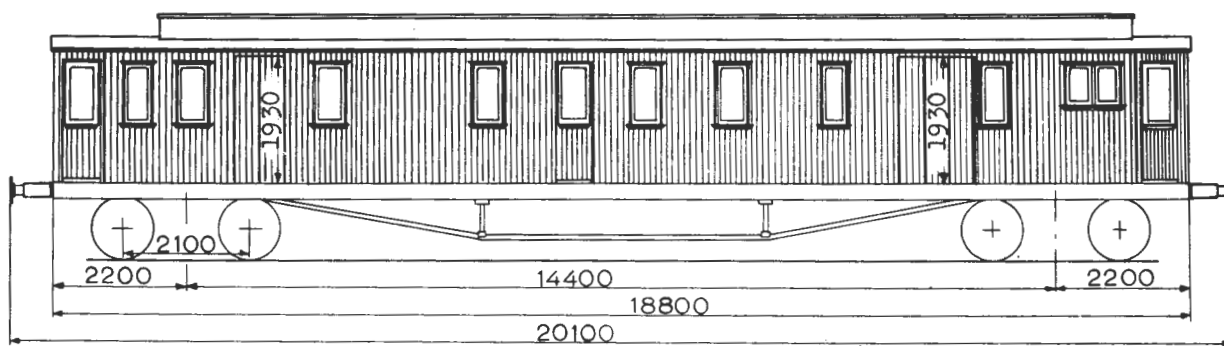
Oppr. hovedt. 968¹⁾

Vogn nr.	Distriktsmerke	Fabrikant	Byggeår	Omtr. vognvekt i tonn	Post, last i tonn	Reisegods, last i tonn	Grunnriss	El. varme i kW	Vognutstyr (se side 6)	Merknad
517	D	Skb	09	28,5	3,5	2,0			1H.3.5.8.11.28.39a	

1) Forandr. etter tegn. 5488 og skisse 1248

DFo-22

TYPE 4

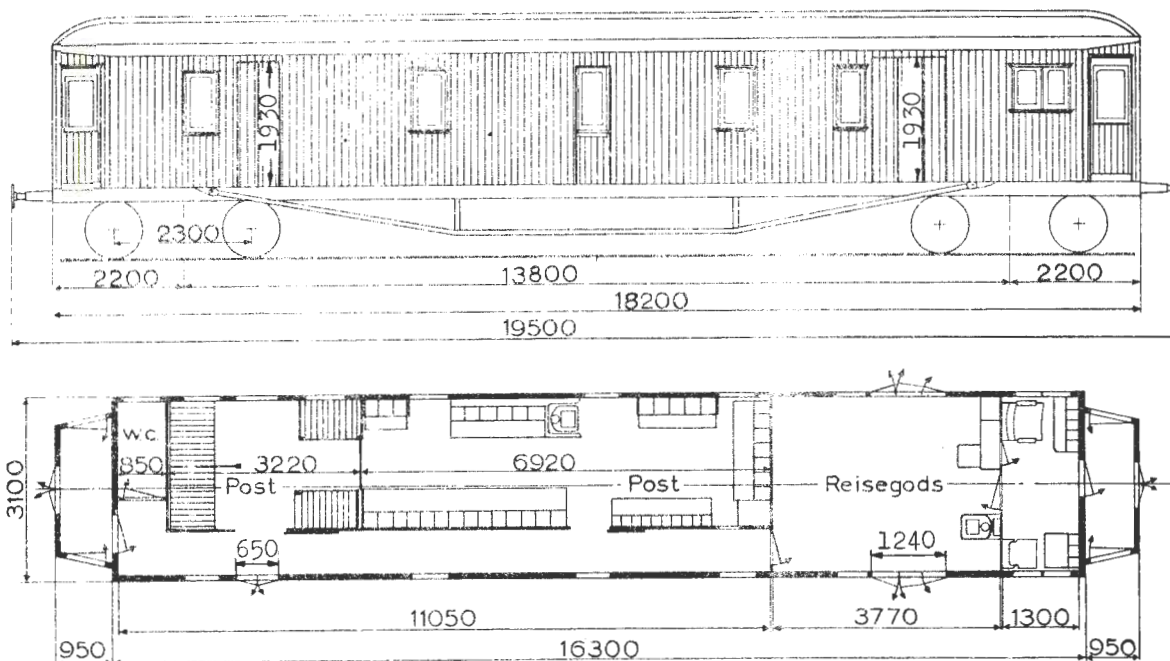

Oppr. hovedt. 1853¹⁾

Vogn nr.	Distriktsmerke	Fabrikant	Byggeår	Omr. vognvekt i tonn	Post, last i tonn	Reisegods, last i tonn	Grunnriss	El. varme i kW	Vognutstyr (se side 6)	Merknad
432	B	SMv	20	32,0	4,5	1,5			1H.3.5.8.11.28.39a.99	

1) Forandr. etter tegn. 6350
Trykk nr. 751 1.7.66

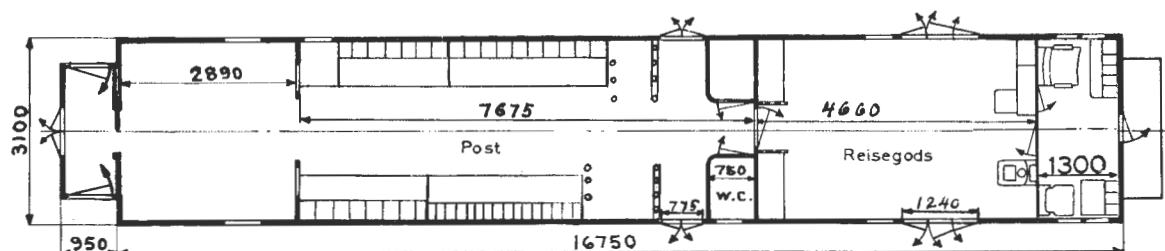
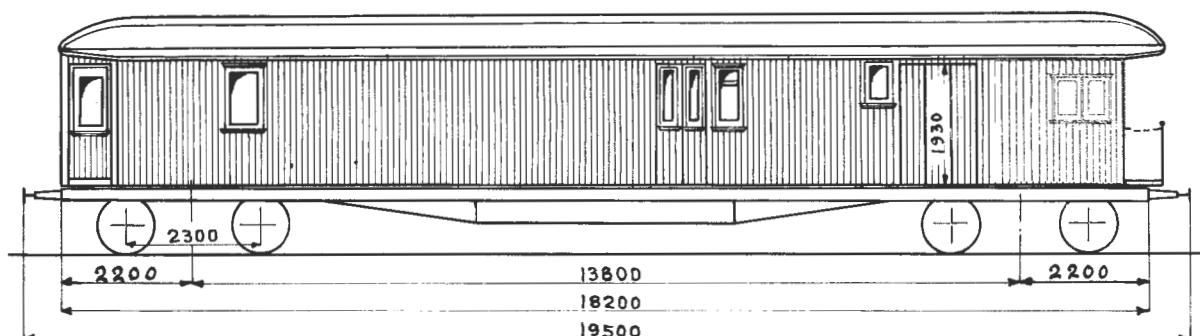
Oppr. hovedt. 2114¹⁾

Vogn nr.	Distriktsmerke	Fabrikant	Byggeår	Omr. vognvekt i tonn	Post, last i tonn	Reisegods, last i tonn	Grunnriss	El. varme i kW	Vognutstyr (se side 6)	Merknad
18010	0	Skb	14	31,5	6,5	4,5			1H.3.5.8.11.28.39a	

1) Forandr. etter tegn. 7058

Trykk nr. 751 1.7.66

DFo-32

TYPE 2

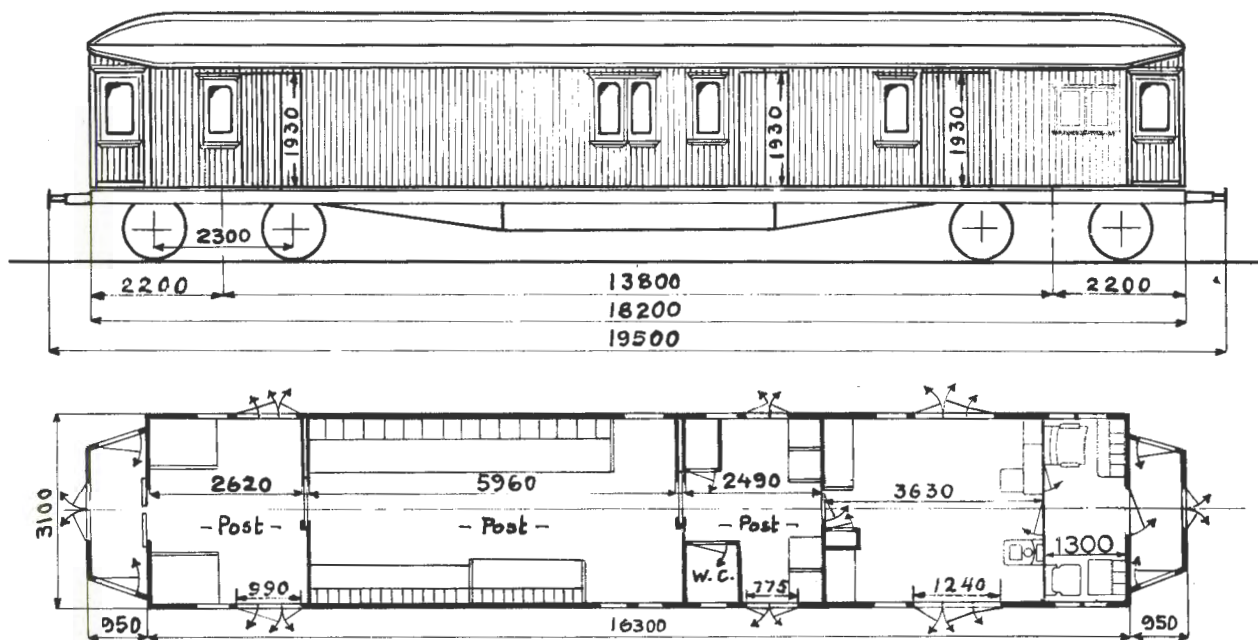

Oppr. hovedt. 1853¹⁾

Vogn nr.	Distriktsmerke	Fabrikant	Byggeår	Omr. vognvekt i tonn	Post, last i tonn	Reisegods, last i tonn	Grunnriiss	El.varme i kW	Vognutstyr (se side 6)	Merknad
622	D	SMv	20	30,5	5,5	3,5			1H.3.5.8.11.28.39a.99	

1) Forandr. etter tegn. 4940
Trykk nr. 751 1.7.64

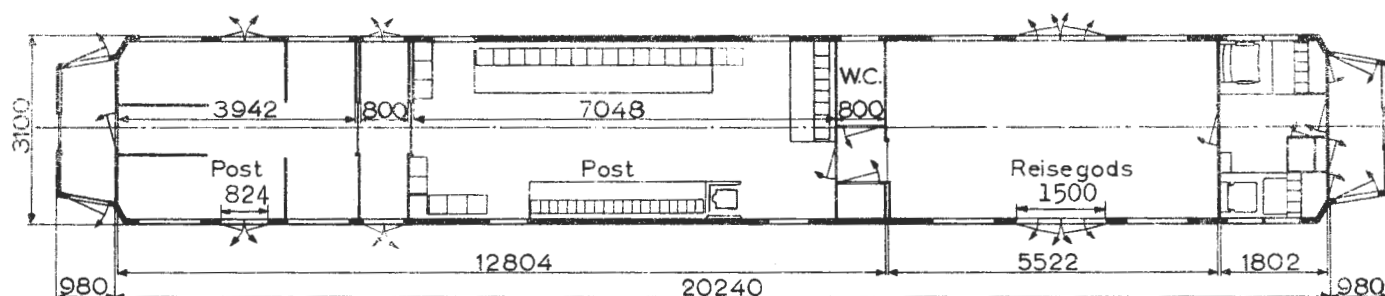
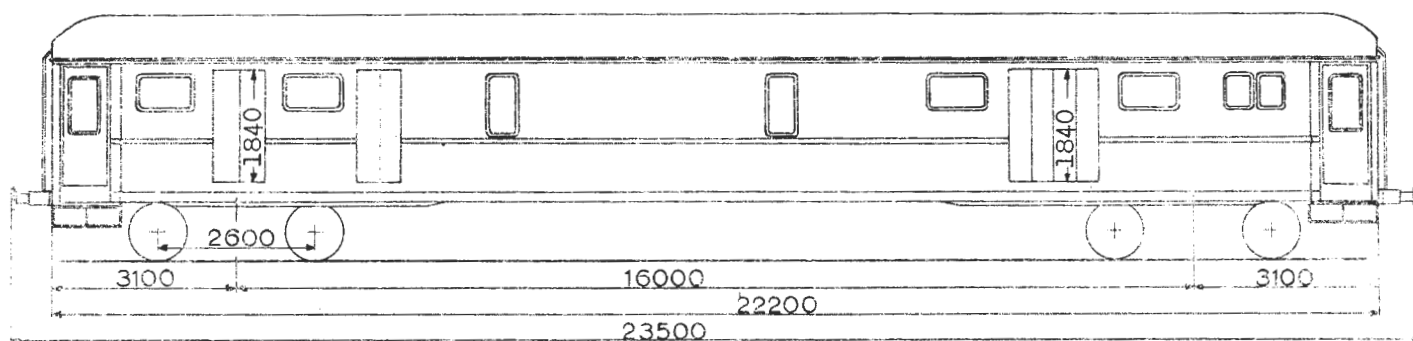
Hovedt. 6565¹⁾
12354¹⁾

Vogn nr:	Distriktsmerke	Fabrikant	Byggeår	Omtr. vognvekt i tonn	Post, last i tonn	Reisegods, last i tonn	Grunnriss	El. varme i kW	Vognutstyr (se side 6)	Merknad
21304	B	Skb	54	38,0	6,7	3,0	23	1KE.3.5.8.11.28.39a		
21305	"	"	55	37,0	"	"	"	1KE.3.5.8.11.28.39a		
21306	0	"	54	37,5	"	"	"	1KE.3.5.8.11.28.39a		
21307	"	"	55	36,5	"	"	"	1KE.3.5.8.11.28.39a		
21318		Str	65	36,0	"	"	"	1KEs.3.12.28 ²⁾ .39a		
21319		"	"	"	"	"	"	1KEs.3.12.28 ²⁾ .39a		
21320		"	"	"	"	"	"	1KEs.3.12.28.39a		
21321		"	"	"	"	"	"	1KEs.3.12.28.39a		

1) For vg. nr. 21318-21321

2) Bare i ende ved kond.rom

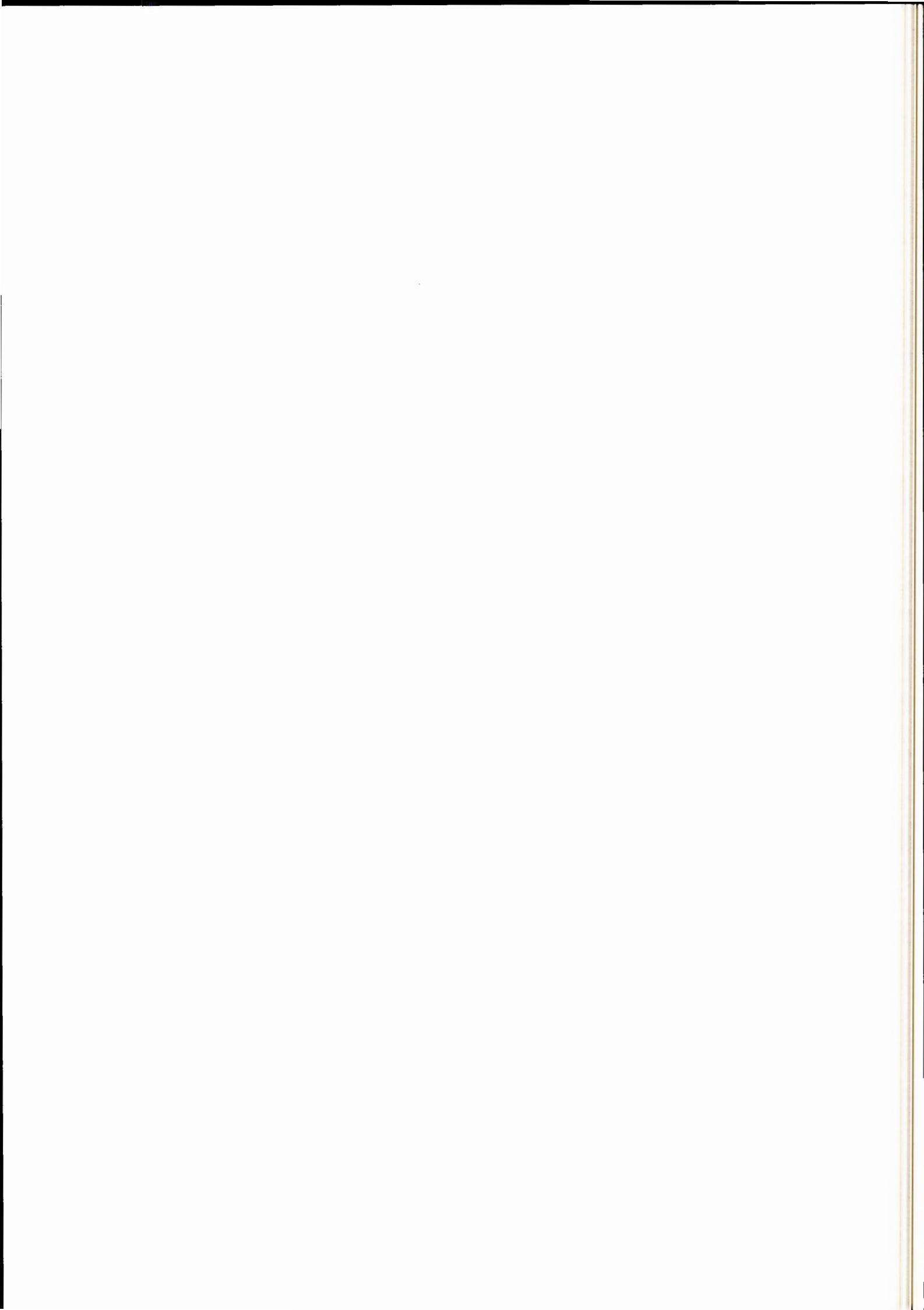

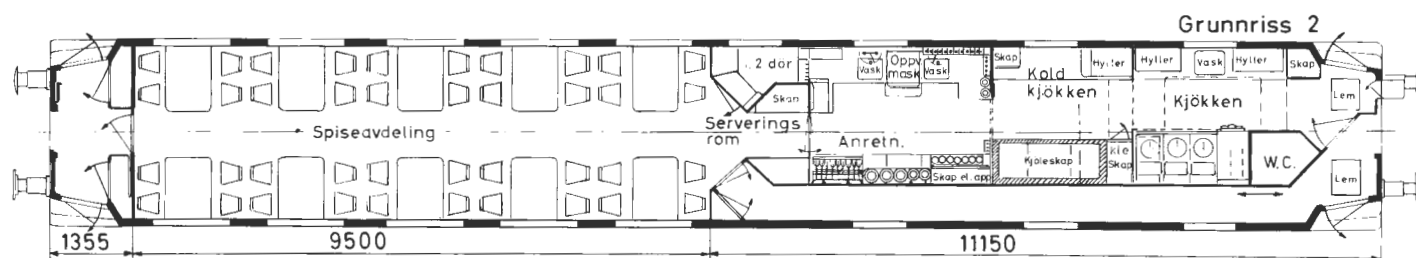
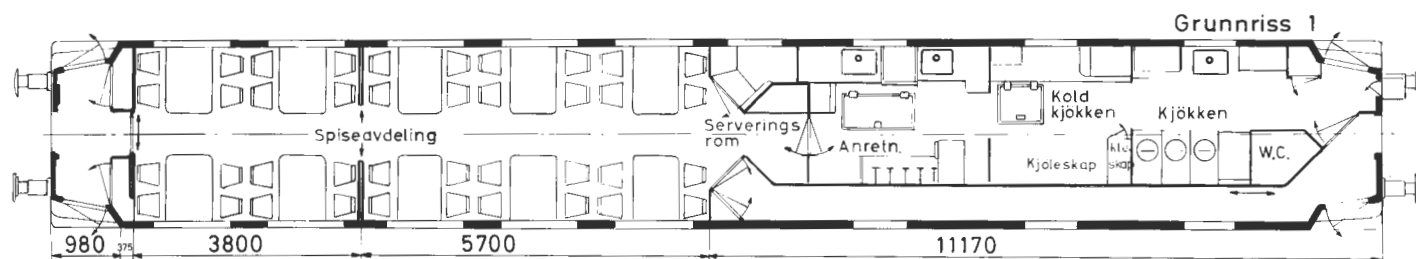
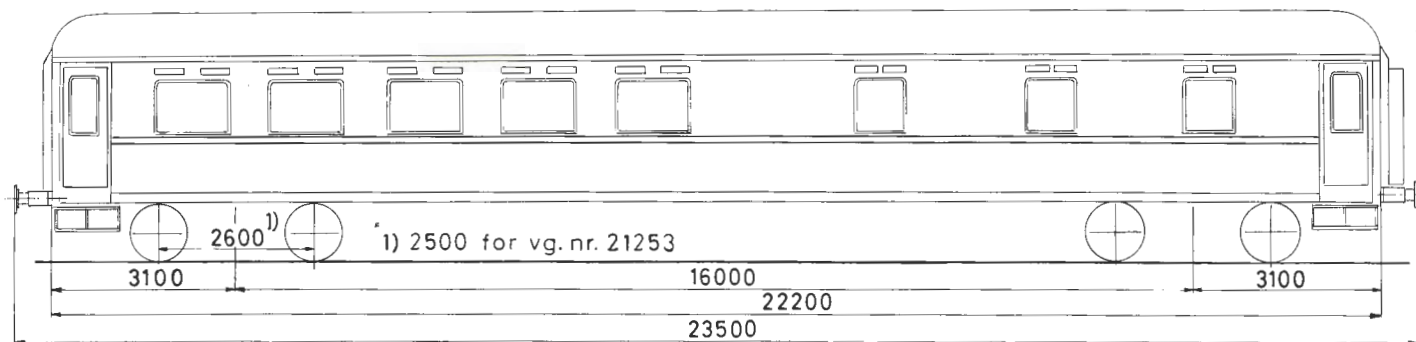

Hovedt. 7650

Vogn nr.	Distriktsmerke	Fabrikant	Byggeår	Omr. vognvekt i tonn	Sittepl.	Grunnriss	El. varme i kW	Vognutstyr (se side 6)	Merknad
21251	O	Scd	53	47,0	40	2	100	1 Hs . 3 . 4b.12. 28.39a	
21252	"	"	"	46,0	"	"	"	1 Hs . 3 . 4b.12. 28.39a	
21253	D	"	"	47,5	"	"	"	1 Hs . 3 . 4b.12. 28.39a	
21254	"	"	"	45,5	"	"	"	1 Hs . 3 . 4b.12. 28.39a	
21255	O	Skb	59	46,5	"	1	"	1 KEs. 3 . 4b.12. 28.39a	
21256	"	"	"	"	"	"	"	1 KEs. 3 . 4b.12. 28.39a	

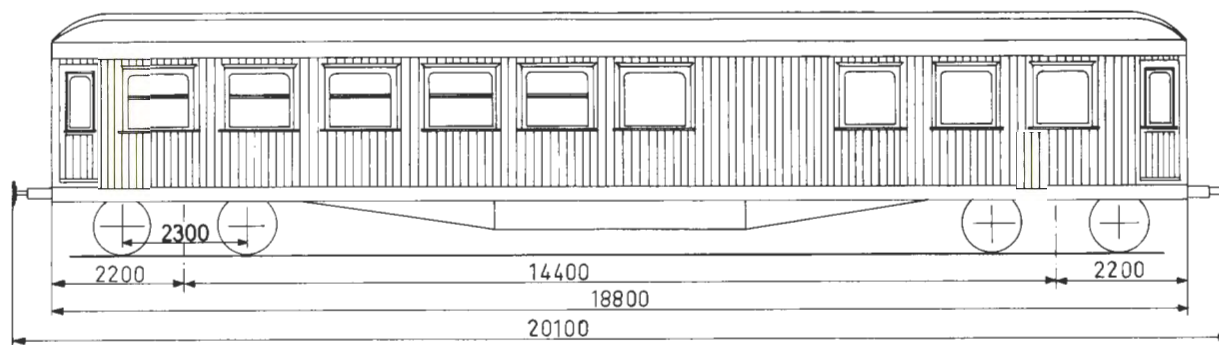

Grunnriss 1

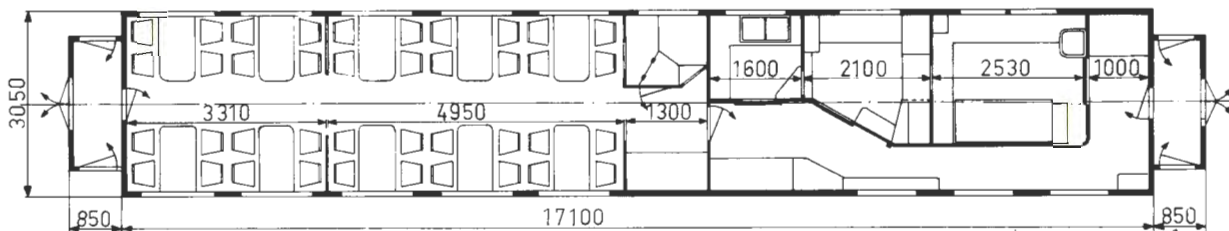

Hovedt. 1116¹⁾

Grunnriss 2

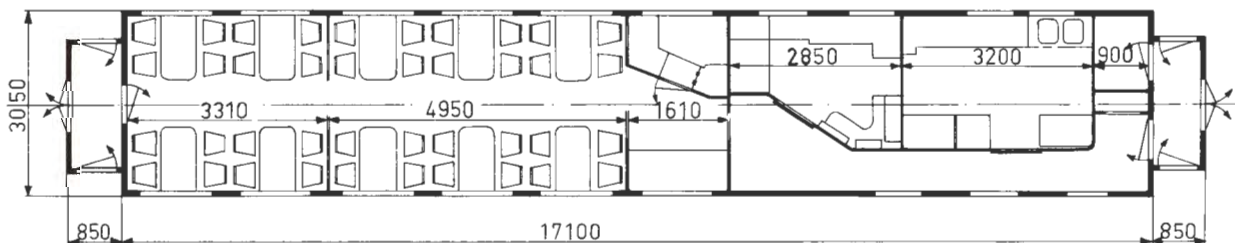

Hovedt. 2068¹⁾²⁾

Grunnriss 3

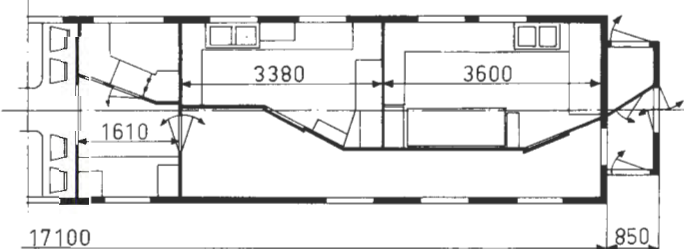

Hovedt. 2068¹⁾

Vogn nr.	Distriktsmerke	Fabrikant	Byggeår	O mtr. vognvekt i tonn	Sittepl.	Grunnriss	Elvarme i kW	Vognutstyr (se side 6)	Merknad
945	B	Skb	09	33,5	40	2		1H.3.5.11.28.39a	
978	"	"	10	35,0	"	1		1H.3.5.11.28.39a	
979	"	"	11	34,5	"	3		1H.3.5.11.28.39a	
980	"	"	"	34,0	"	1		1H.3.5.11.28.39a	

1) Forandr. etter skisse 1536

2) Forandr. etter tegn. 8262, 8263

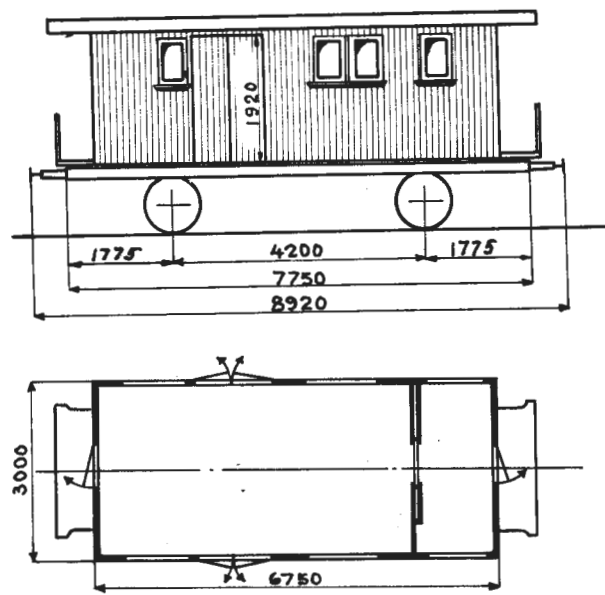

Hovedt. 339

Vogn nr.	Distriktsmerke	Fabrikant	Byggeår	Omtr. vognvekt i tonn	Reisegods, last i tonn	Grunnriss	El.varme i kW	Vognutstyr (se side 6)	Merknad
2007	0	Skb	97	9,0	3,0			3.6.8.13.15.24	

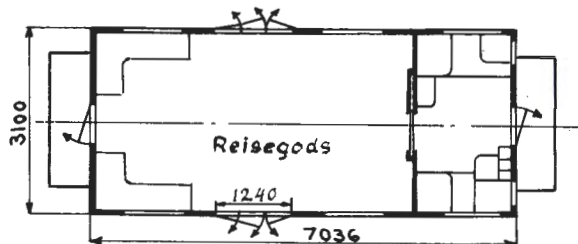
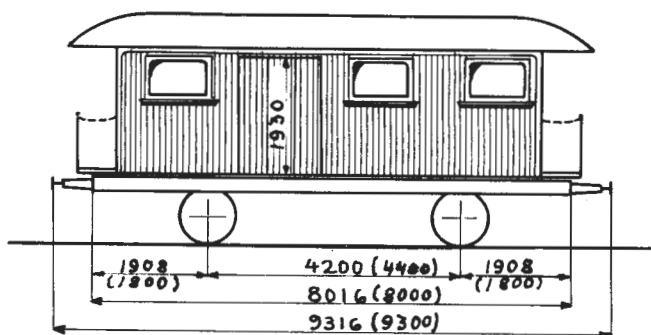

Grunnriss 1
Hovedt. B. 543

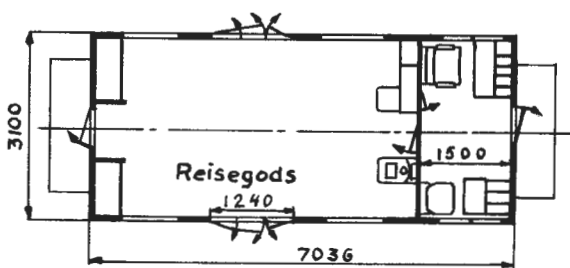

Grunnriss 2
Oppr. hovedt. 478¹⁾
992¹⁾

Vogn nr.	Distriktsmerke	Fabrikant	Byggeår	Omtr. vognvekt i tonn	Reisegods, last i tonn	Grunnriss	El. varme i kW	Vognutstyr (se side 6)	Merknad
1007	O	Skb	97	15,5	0,5	1		3.5.8.13.15	
14003	B	Str	07	10,5	3,0	2		1H.3.6.8.13.24	2)
15011	D	Skb	09	11,5	"	"		1H.3.6.8.11.24.40	3)

Mål i () gjelder vogner etter grunnriss 2

1) Ny vognkasse etter tegn. 6499

2) Oppr. hovedt. 478

3) " " 992

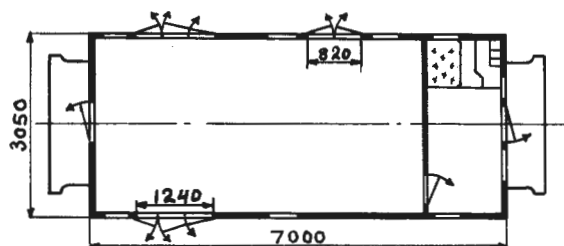
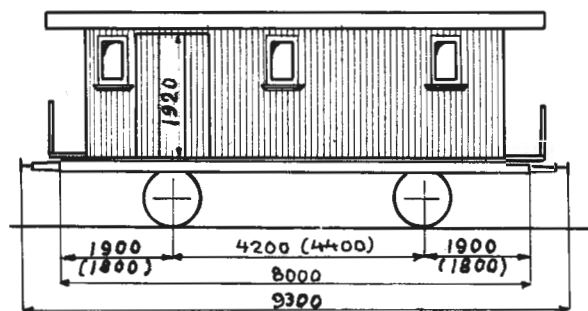

Grunnriss 1

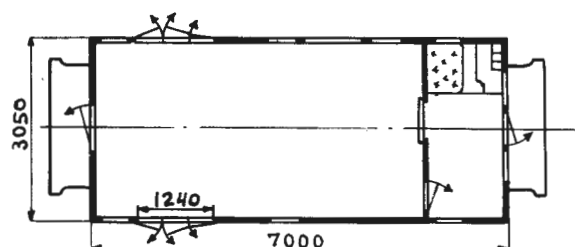

Grunnriss 2

Oppr. hovedt. 478

Vogn nr:	Distriktsmerke	Fabrikant	Byggeår	Omr. vognvekt i tonn	Reisegods, last i tonn	Grunnriss	El. varme i kW	Vognutstyr (se side 6)	Merknad
2011	O	Skb	00	9,5	3,0	1		3.6.8.13.15	1)
6001	"	"	"	"	"	"		3.6.8.13.15	
6007	"	"	"	"	"	"		3.6.8.13.15	
9004	B	"	04	10,0	4,0	2		3.6.8.13.15.24	
14002	D	Str	07	10,5	2,5	1		1H.3.6.8.13.24	

Mål i () gjelder for grunnriss 2
1) Kond.rom utvidet til 1800 mm

F

TYPE 7

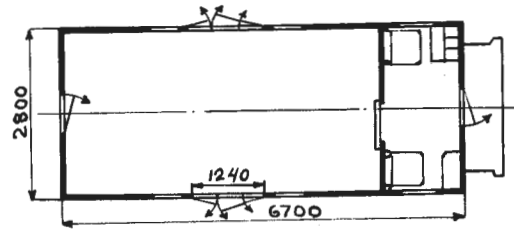
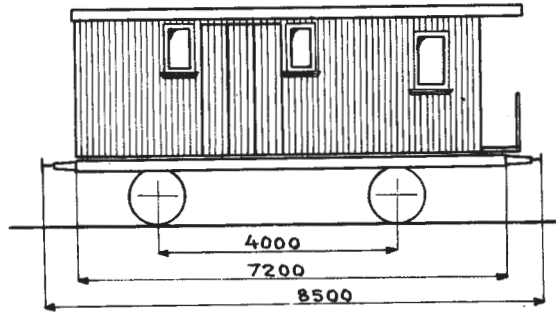

Hovedt. Oslo d. 882

Vogn nr.	Distriktsmerke	Fabrikant	Byggeår	Omr. vognvekt i tonn	Reisegods, last i tonn	Grunnriss	El.varme i kW	Vognutstyr (se side 6)	Merknad
2019	0	AaB	10	9,5	5,0			3.6.8.13.15.24	

Trykk nr. 751 1.7.66

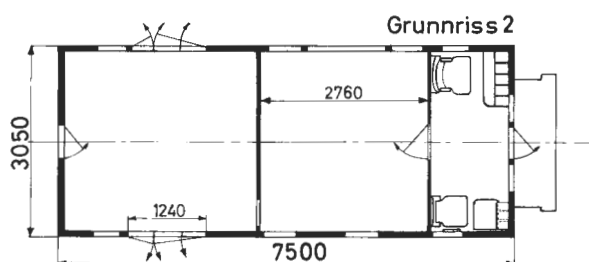
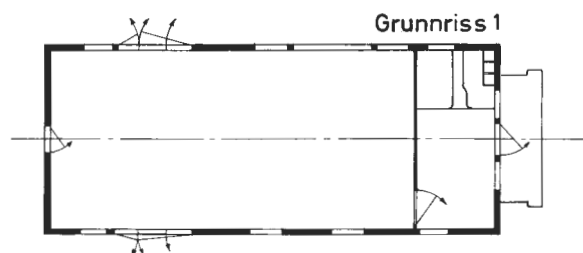
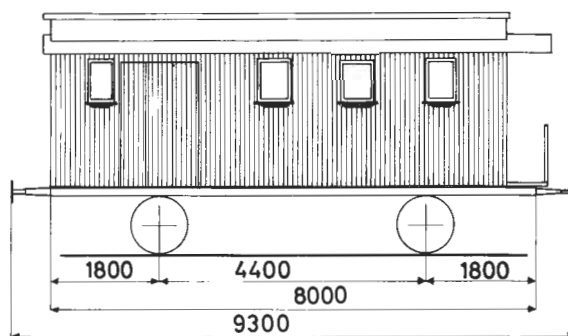

Hovedt. 992

Vogn nr.	Distriktsmerke	Fabrikant	Byggeår	Omr. vognvekt i tonn	Reisegods last i tonn	Grunnriss	El. varme i KW	Vognutstyr (se side 6)	Merknad
5009	H	Skb	11	9,5	3,0	1		3. 6. 8. 13. 15. 24	
6008	O	"	09	10,0	"	"		3. 6. 8. 13. 15. 24	
14005	B	"	"	10,5	"	"		3. 6. 8. 13. 15. 24. 40	
14006	"	"	"	11,0	"	"		3. 6. 8. 13. 15. 24	
14007	"	"	"	10,5	"	"		1H. 3. 6. 8. 13. 24	
14008	"	"	"	"	"	"		1H. 3. 6. 8. 13. 24. 40	
14009	"	"	"	10,0	"	"		3. 6. 8. 13. 15. 24. 40	
15008	D	"	"	10,5	"	"		1H. 3. 6. 8. 13. 24. 40	
15009	"	"	"	"	"	"		1H. 3. 6. 8. 13. 24. 40	
15012	"	"	"	"	"	"		1H. 3. 6. 8. 13. 24. 40	
15013	K	"	11	"	"	2		1H. 3. 6. 8. 11. 24. 40	
15014	D	"	"	"	"	"		1H. 3. 5. 8. 13. 24. 40	
15015	"	"	"	13,5	"	"		1H. 3. 6. 8. 13. 24	

1)

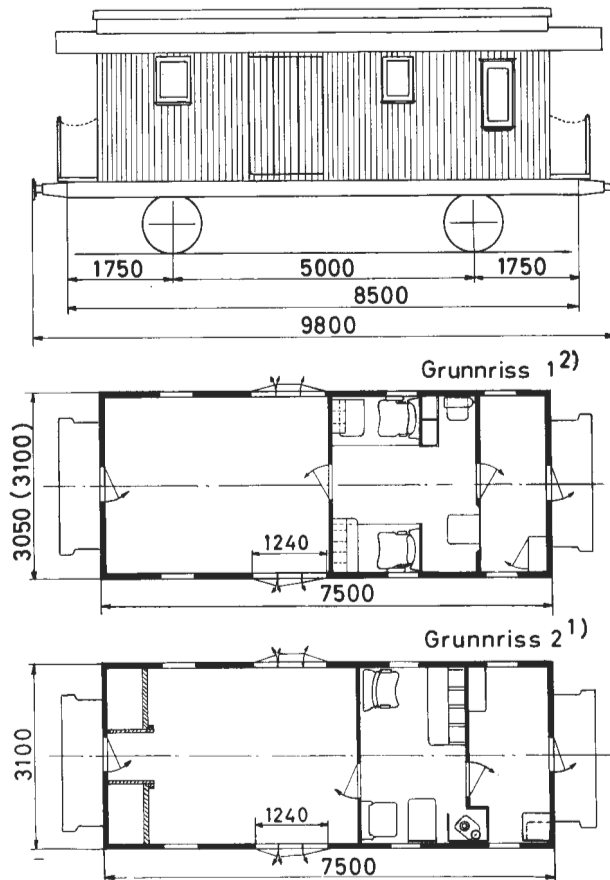

Oppr. hovedt.1254

Vogn nr.	Distriktsmerke	Fabrikant	Byggeår	Omr. vognvekt i tonn	Reisegods, last i tonn	Grunnriss	El.varme i kW	Vognutstyr (se side 6)	Merknad
3009	O	Str	13	11,5	1,0	1		1H.3.6.8.11.24.39a	
3010	"	"	"	11,0	"	"		1H.3.6.8.11.24.39a	
3011	"	"	"	"	"	"		1H.3.6.8.11.24.39a	
3012	"	"	"	11,5	"	"		1H.3.6.8.11.24.39a	
5014	H	Skb	19	"	"	"		1H.3.6.8.11.24	3)
6010	O	"	12	12,0	2,0	2		1H.3.6.8.11.24	
6011	"	"	"	"	1,0	1		1H.3.6.8.11.24.39a	
6012	"	Str	13	11,5	"	"		1H.3.6.8.11.24.39a	
6013	"	"	"	"	"	"		1H.3.6.8.11.24.39a	
6025	"	Skb	"	"	"	"		1H.3.6.8.11.24	

1) Forandr, etter Krs d. skisse dat. 27.9.61

2) Kond.rom forandr, etter tegn. 12422

3) Oppr. hovedt.2104. Hvelvet tak

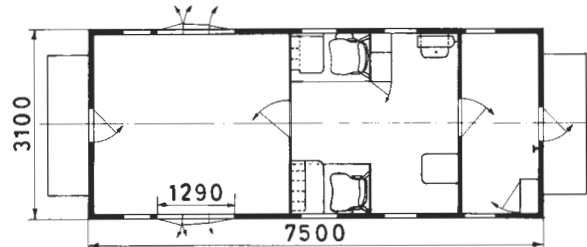
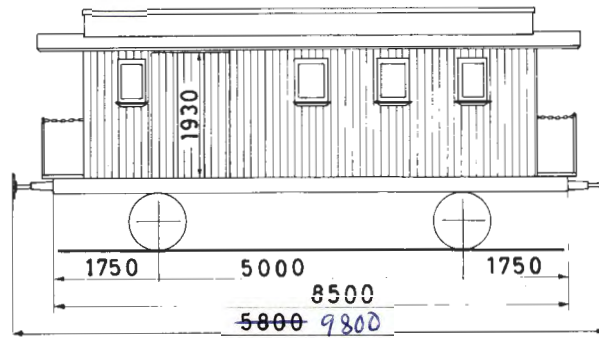

Oppr. hovedt. 1930¹⁾
2104¹⁾

Vogn nr.	Distriktsmerke	Fabrikant	Byggeår	Omr. vognvekt i tonn	Reisegods, last i tonn	Grunnriss	El. varme i KW	Vognutstyr (se side 6)	Merknad
2022	O	Str	13	12,0	1,0			1H. 3.6.8.11.24	
2024	"	Skb	19	"	"			1H. 3.6.8.11.24	
3030	"	"	"	11,5	"			1H. 3.6.8.11.24	
3031	"	"	"	"	"			1H. 3.6.8.11.24	
5012	H	"	"	12,0	"			1H. 3.6.8.11.24	
5013	"	"	"	"	"			1H. 3.6.8.11.24	
5015	"	"	"	"	"			1H. 3.6.8.11.24	
5016	"	"	"	11,0	"			1H. 3.6.8.11.24.39a	
5634	T	Str	14	12,0	"			1H. 3.6.8.11.24	
5635	"	"	"	"	"			1H. 3.6.8.11.24	
6014	O	Skb	19	"	"			1H. 3.6.8.11.24.39a	2)
6015	"	"	"	11,0	"			1H. 3.6.8.11.24	
6016	"	"	"	12,0	"			1H. 3.6.8.11.24	
14010	B	"	15	"	"			1H. 3.6.8.11.24.40	2)
14011	"	"	19	"	"			1H. 3.6.8.11.24.40	
14012	"	"	"	"	"			1H. 3.6.8.11.24.40	
17952	T	"	"	"	"			1H. 3.6.8.11.24	
17953	"	"	"	11,5	"			1H. 3.6.8.11.24	
17954	"	"	"	12,0	"			1H. 3.6.8.11.24	2)
20051	K	"	14	11,0	"			1H. 3.6.8.11.24	
20052	D	"	"	12,0	"			1H. 3.6.8.11.24	
20053	"	"	"	"	"			1H. 3.6.8.11.24	
23101	"	"	15	11,5	"			1H. 3.6.8.11.24	
23102	"	"	"	12,0	"			1H. 3.6.8.11.24	

1) Kond. rom forandr. etter tegn.12422

2) Oppr. hovedt. 1930

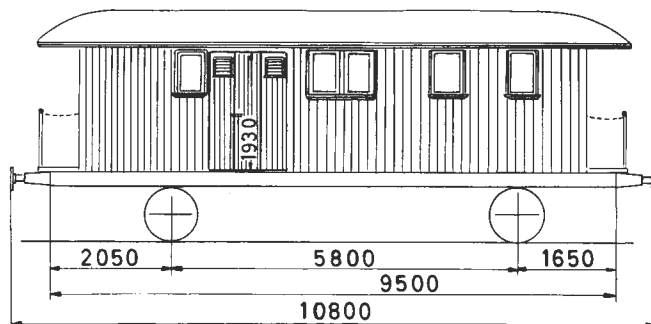

Grunnriss 1

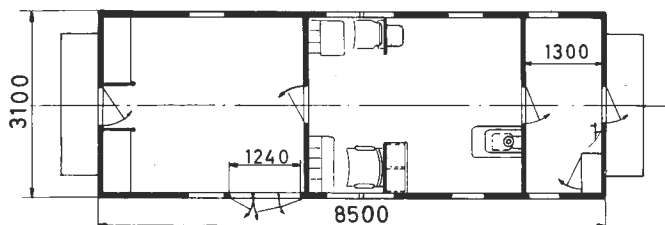

Grunnriss 2

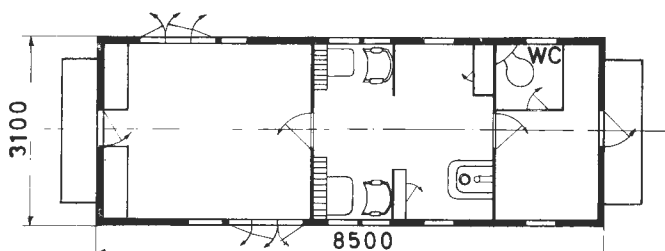

Oppr. hovedt. 2531, 2558

Vogn nr.	Distriktsmerke	Fabrikant	Byggeår	Omr. vognvekt i tonn	Reisegods, last i tonn	Grunnriss	El-varme i kW	Vognutstyr (se side 6)	Merknad
2025	O	Str	22	13,0	1,0	1		1H.3.6.8.11.24	
2026	"	"	"	12,5	"	"		1H.3.6.8.11.24	
2027	"	"	"	"	"	"		1H.3.6.8.11.24	
2028	"	"	"	"	"	"		1H.3.6.8.11.24	
2030	"	"	"	13,0	"	"		1H.3.6.8.11.24.39a	
3033	"	"	"	12,5	"	"		1H.3.6.8.11.24.40	
3034	"	"	"	"	"	2		1H.3.6.8.11.24.40	
3035	"	"	"	"	"	1		1H.3.6.8.11.24	
3036	"	"	"	13,0	"	"		1H.3.6.8.11.24	
3037	"	"	"	"	"	"		1H.3.5.8.11.24.39a	
3038	"	"	"	"	"	"		1H.3.6.8.11.24	
3039	"	"	"	12,5	"	"		1H.3.6.8.11.24	
5020	H	"	"	"	"	"		1H.3.6.8.11.24	1)
5021	"	"	24	"	"	"		1H.3.6.8.11.24	1)
5022	"	"	"	13,0	"	"		1H.3.6.8.11.24	1)
5023	"	"	"	12,0	"	"		1H.3.6.8.11.24	

1) Oppr. hovedt. 2531

Trykk nr. 751 1.7.65

Vogn nr.	Distriktsmerke	Fabrikant	Byggeår	Omr: vognvekt i tonn	Reisegods, last i tonn	Grunnriss	El.varme i kW	Vognutstyr (se side 6)	Merknad
5024	H	Str	24	12,0	1,0	1		1H.3.6.8.11.24	
6017	O	"	22	13,0	"	"		1H.3.6.8.11.24.40	
6018	"	"	"	12,5	"	"		1H.3.6.8.11.24.40	
6019	"	"	"	13,0	"	"		1H.3.6.8.11.24.40	
6020	"	"	"	12,5	"	"		1H.3.6.8.11.24.40	
6021	"	"	"	"	"	"		1H.3.6.8.11.24.40	
6022	"	"	"	"	"	"		1H.3.6.8.11.24	
17950	H	"	24	12,0	"	"		1H.3.6.8.11.24	1)
20054	D	"	"	13,0	"	"		1H.3.6.8.11.24.39a	
20055	"	"	"	"	"	"		1H.3.6.8.11.24.40	
20056	"	"	"	13,5	"	"		1H.3.6.8.11.24.40	
20057	"	"	"	13,0	"	"		1H.3.8.11.24.39a	
20773	"	"	"	"	"	"		1H.3.6.8.11.24	1)
20774	K	"	"	12,5	"	"		1H.3.6.8.11.24	1)

1) Oppr. hovedt. 2531

F

TYPE 13

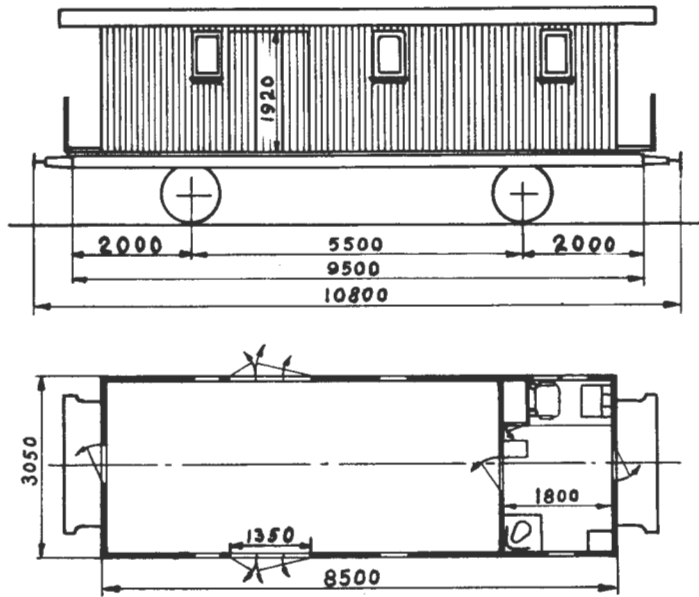

Oppr. hovedt. 662

Vogn nr:	Distriktsmerke	Fabrikant	Byggeår	Omr. vognvekt i tonn	Reisegods, last i tonn	Grunnriss	El. varme i kW	Vognutstyr (se side 6)	Merknad
13022	0	Skb	02	11,0				3.6.8.13.15.24	

Fo

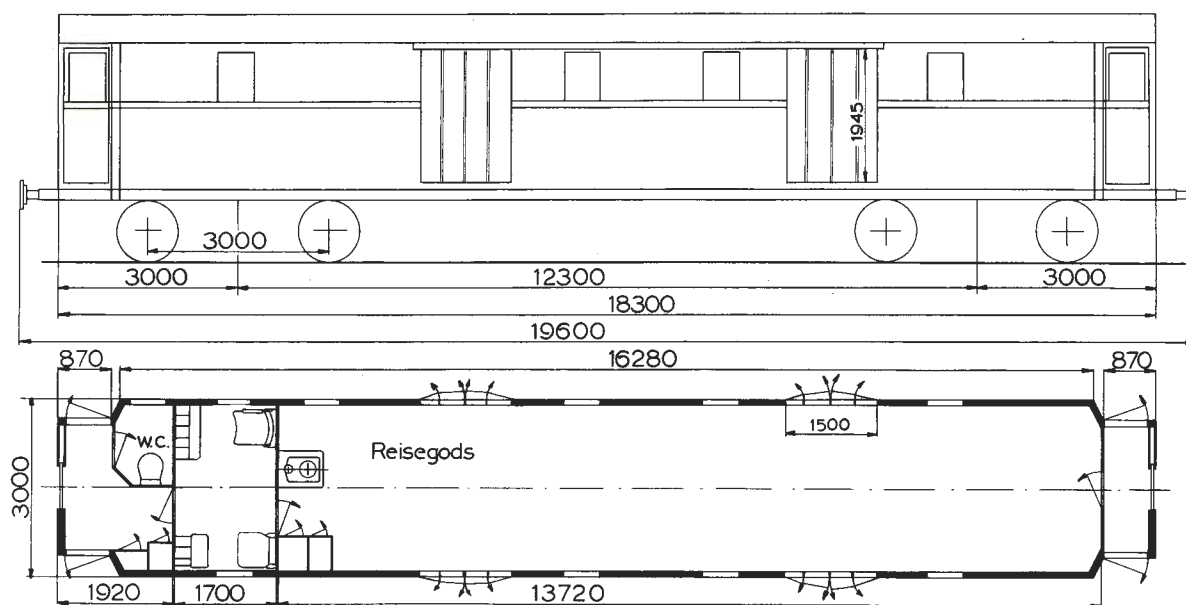
TYPE 6
Stålvogner

Hovedt.skisse 915

Vogn nr.	Distriktsmerke	Fabrikant	Byggeår	Omtr. vognvekt i tonn	Reisegods, last i tonn	Grunniss	El. varme i kW	Vognutstyr (se side 6)	Merknad
19951	0		31	31,5	10,0			1H. 3. 5. 8. 11. 28.39a	
19952	0		32	30,5	10,0			1H. 3. 5. 8. 11. 28.39a	

Fo

TYPE 7

Stålvogner

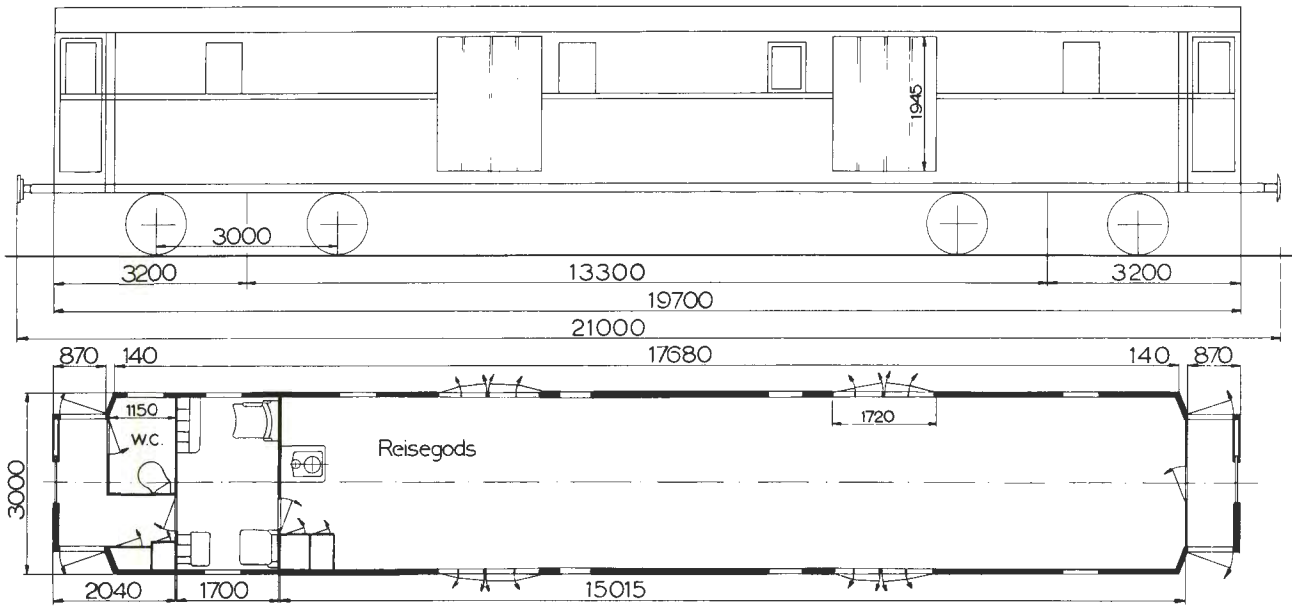

Hovedt skisse 916

Vogn nr.	Distriktsmerke	Fabrikant	Byggeår	Omtr. vognvekt i tonn	Reise gods, last i tonn	Grunnriss	El. varme i kW	Vognutstyr (se side 6)	Merknad
19953	0		33	30,5	10,0			1H. 3. 5. 8. 11. 28. 39a	

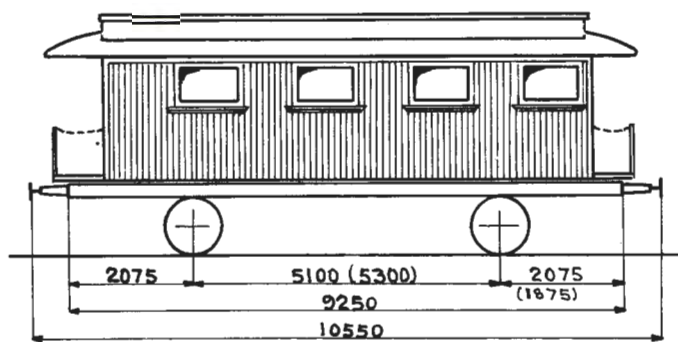

Grunnriss 1

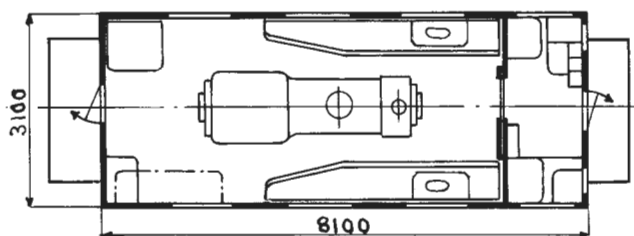

Grunnriss 2

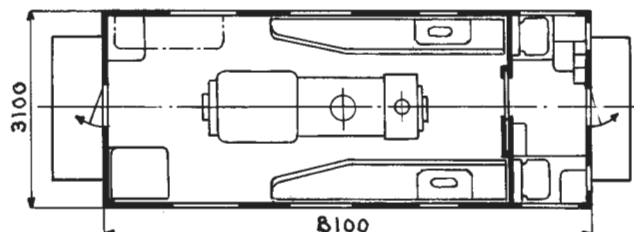

Hovedt. gr.riss 1: B 515
" 2: 3043

Vogn nr	Distriktsmerke	Fabrikant	Byggeår	Gmtr. vognvekt i tonn	Reisegods, last i tonn	Grunnriss	El.varme i kW	Vognutstyr (se side 6)	Merknad
1025	0	NHJ	23	19,0		1		1H.3.5.8.13.24	
1026	"	"	"	"		"		1H.3.5.8.10.24	
1027	"	"	"	18,5		"		1H.3.5.8.10.24	
3040	"	Skb	28	17,5		2		1H.3.6.8.13.24	
3041	"	"	"	18,0		"		1H.3.6.8.10.24	
3042	"	"	"	17,5		"		1H.3.6.8.10.24	
3043	"	"	"	18,0		"		1H.3.6.8.10.24	

Mål i () gjelder grunnriss 2
Trykk nr. 751 1.7.66

Fd

TYPE 4

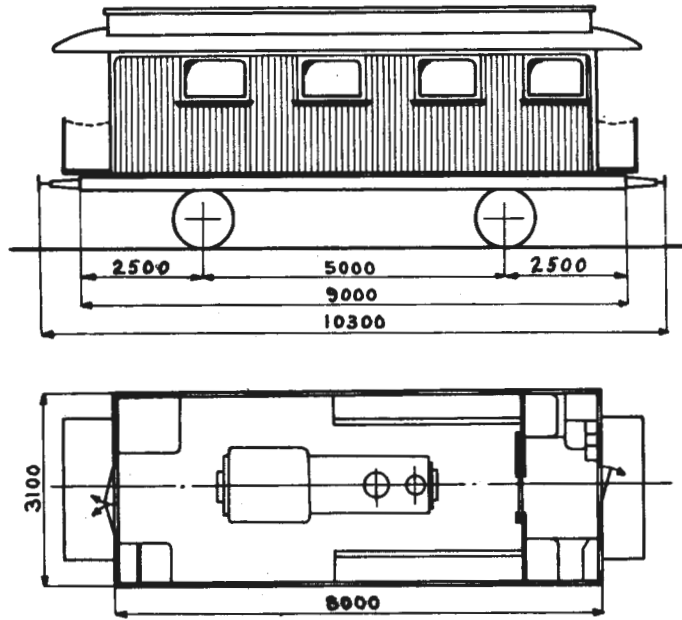

Hovedt. B. 482

Vogn nr.	Distriktsmerke	Fabrikant	Byggeår	Omr. vognvekt i tonn	Reisegods, last i tonn	Grunnriss	El.varme i kW	Vognutstyr (se side 6)	Merknad
1023	0	NHJ	21	18,5				3.5.8.13.15.24	
1024	"	"	"	"				3.5.8.13.15.24	

Trykk nr. 751 1.7.56

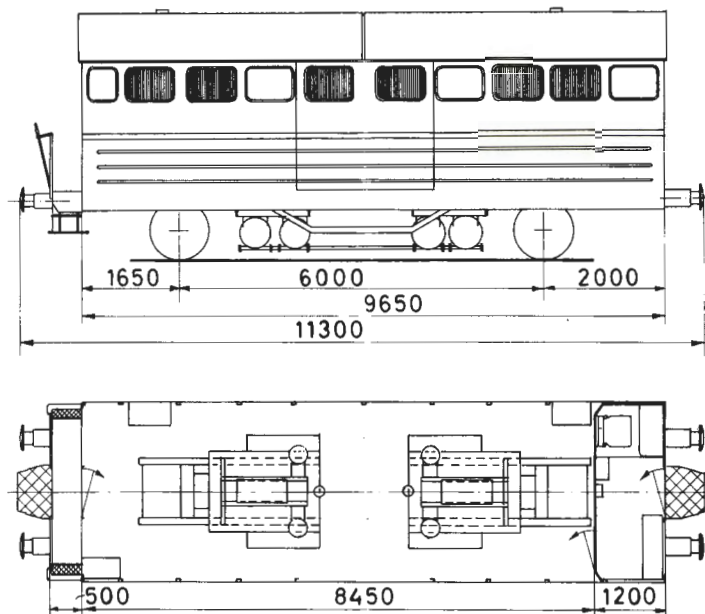

Hovedt. 15699 ¹⁾

Vogn nr.	Distriktsmerke	Fabrikant	Byggeår	Omr. vognvekt i tonn	Reisegods, last i tonn	Grunnriss	El. varme i kW	Vognutstyr (se side 6)	Merknad
19004		Str	35	25,0				1H. 3. 6.12.24	

¹⁾Omb. fra G4 type1 (hovedt.3300) ved vst. Oslo i 1966.

